

PERSPECTIVE

EARTHSAFE	Title UM3C DEF CHILLER SET	Project 74100	Date 2-1-20	By WE	ID UM3C001	No. 01
-----------	-------------------------------	------------------	----------------	----------	---------------	-----------

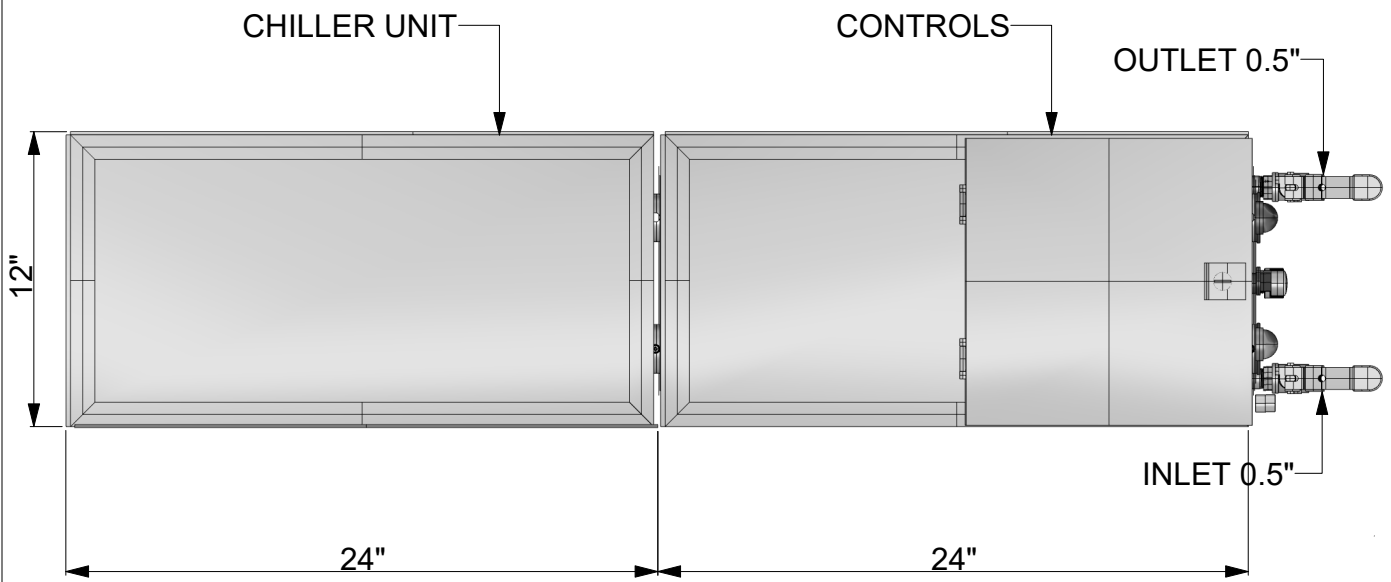

PLAN VIEW

EARTHSAFE	Title UM3C DEF CHILLER SET	Project 74100	Date 2-1-20	By WE	ID UM3C001	No. 02
-----------	-------------------------------	------------------	----------------	----------	---------------	-----------

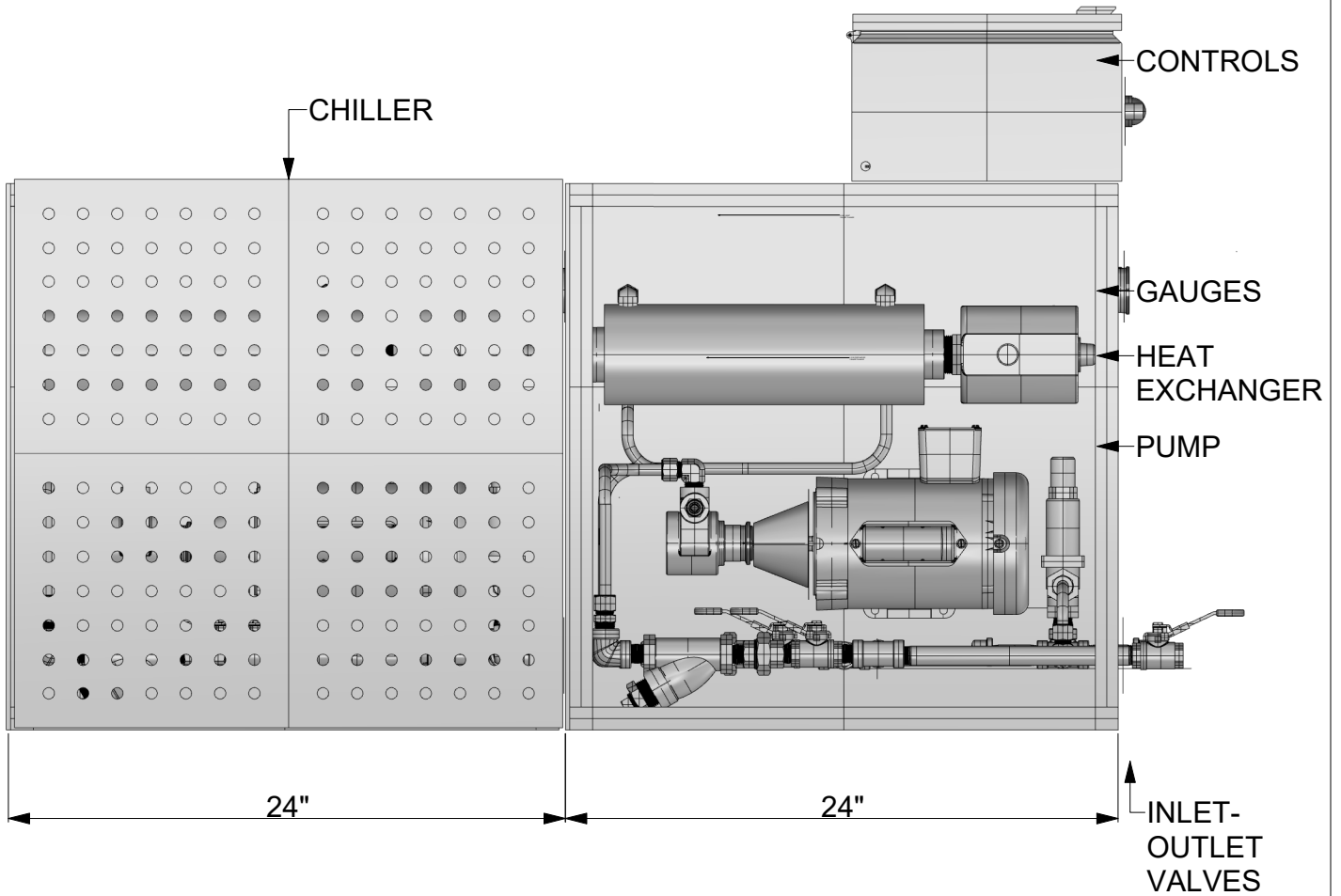

SIDE VIEW

EARTHSAFE	Title UM3 DEF CHILLER SET	Project 74100	Date 2-1-20	By WE	ID UM3C001	No. 03
-----------	------------------------------	------------------	----------------	----------	---------------	-----------

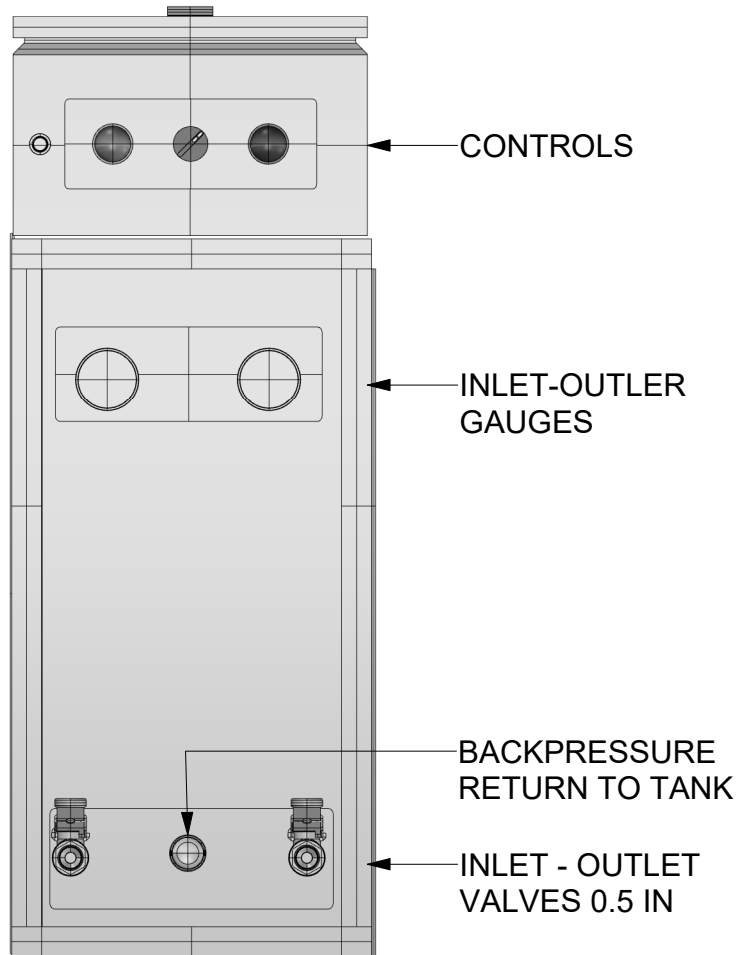

FRONT VIEW

EARTHSAFE	Title UM3C DEF CHILLER SET	Project 74100	Date 2-1-20	By WE	ID UM3C001	No. 04
-----------	-------------------------------	------------------	----------------	----------	---------------	-----------

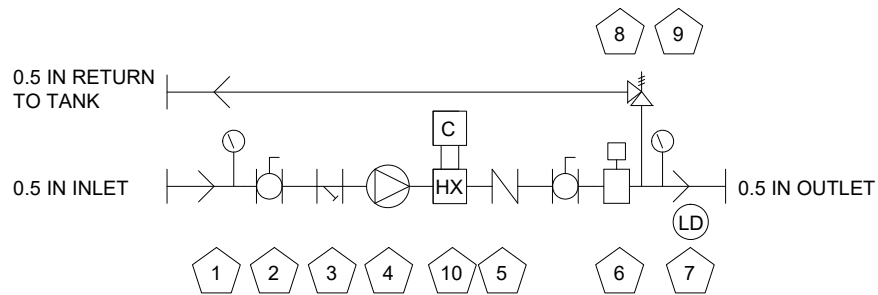

FLOW DIAGRAM

MARK	QTY	SIZE	MODEL	DESCRIPTION
1	1	1.5	COM	INLET SUCTION GAUGE 0-30, SS304
2	2	0.5	APL	BALL VALVES - SS304
3	1	0.5	DWY	STRAINER - SS304
4	1	0.5	FLU	PUMP, POSITIVE DISPLACEMENT, 1-10 GPM, SS304
				MOTOR, 120/230 VAC-1 PH-50/60 Hz, 0.33 HP
5	1	0.5	APL	CHECK VALVE - SS304
6	1	0.5	PRO	FLOW SENSOR - SS304
7	1	NA	FPI	LEAK SENSOR - SS304
8	1	0.5	FUL	BACK PRESSURE REGULATOR - SS304, 3-10 PSI
9	1	1.5	COM	OUTLET PRESSURE GAUGE 0-100 PSI - SS304
10	1		ESS	HEAT EXCHAGER AND CONDENSER
11	1		ESS	ENCLOSURE 24 X 24 X12, SS304
12	1		ESS	C1 CONTROLLER

BILL OF MATERIAL

EARTHSAFE	Title UM3C DEF CHILLER SET	Project 74100	Date 2-1-20	By WE	ID UM3C001	No. 05
-----------	-------------------------------	------------------	----------------	----------	---------------	-----------