

earth^o safe

Fuel Systems for Critical Power

Earthsafe M400

Compact Fill Station with Integral
OmniPlex Network Controller

BACnet, Modbus, Metasys N2, or LON Communications



General Description

Fill System for Tanks in Buildings. The Earthsafe M400 Compact Fill Station is designed for the safe filling of fuel tanks located inside buildings. The system is designed to install outside the building to accept fuel from delivery trucks and safely transfer fuel to the fuel tank in the building.

Overfill Prevention Safety. The system is designed with overfill prevention safety. The electronic controller at the fill station monitors the fuel level in the tank as a continuous level reading (0-100%) or as a set of high level sensors (85-90-95%). The controller provides audible and visual high level warning at 85%, high level alarm at 90%, and critical high level at 95%. The controller monitors the position of actuated fill pipe valves, and closes the valve upon high level.

Single or Multi-Tank Systems. The Earthsafe Compact Fill Station will provide safe filling for a single or multiple fuel storage tanks. In multiple tank systems the controller monitors level sensors in each tank and operates an actuated valve to allow filling of the selected tank.

Passive or Pump Equipped. The fill station is most commonly used with pump equipped fuel delivery trucks. Where facility based pumps are required, the fill station can be equipped with pumps from 30 to 300 GPM (120-1200LPM) capacity.

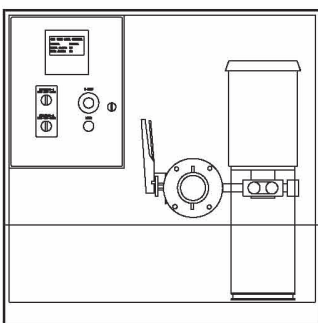
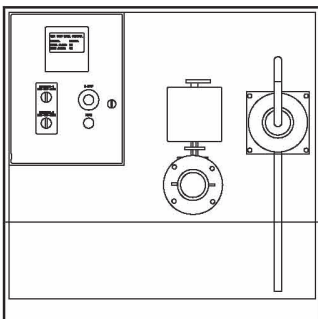
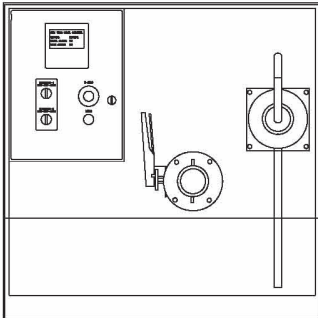

M410 Compact Tank Fill Station (shown)
M415 Compact Tank Fill Station – Pump Flow

Mounting Options:

- Surface Mount
- Flush Mount
- Recess Mount

Flow Options:

- Manual Valve
- Auto Valve
- Pump Flow

Dimensions	24"Wx24"Hx18"D (610x610x460) (610x610x460)
Tank Select	1-4 Tanks
Flow Capacity (GPM)	20 GPM (80 LPM)
Pressure Capacity	100 PSI (690 kPa)
Pump Type (PP350)	Viking PD Pump Close Coupled TEFC Motor 120 VAC Single Phase, or 480-240 VAC Three Phase 1.0 HP @ 25 PSI (0.75 KW)
Accessories	Camlock Connection (2" • 3") (50-75) Outlet Check Valve Shutoff Valve Leak Sensor Hand Pump Tank High Level Sensor Motor Starter / Disconnect High Level Shutoff Valve
Construction	Welded Steel Construction Containment Basin (7 GAL) (30L) Industrial Enamel Finish Color RAL 7035 (Light Gray) Option: Weatherproof Enclosure Option: SS Construction Option: Wall Recess Construct
Controls	C840 Omniplex Module

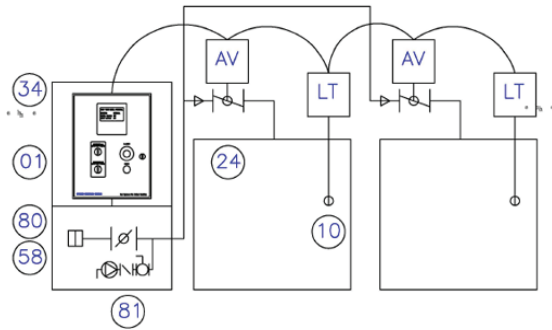

Tank Fill System

Item	Qty	Description
1	1	OmniPlex Control Panel
10	2	Tank Level Sensor
24	2	Actuated Butterfly Valve
34	1	Fill Station Cabinet
58	1	Butterfly Valve
80	1	Hose Adapter / Cap
81	1	Hand Pump Assembly

Tank Fill Control:

The control panel monitors a high level sensor in the fuel tank and controls the opening of the actuated valve in the fill pipe. The tank to be filled is selected at the control panel. The fill line valve is energized to open, as long as the tank level is less than 85%. The fill valve limit switch provides feedback to the panel, so that when filling multiple tanks only one valve is open at any one time.

Fuel is transferred into the tank until the 85% tank level is reached and an audible alarm is activated. The audible alarm operates for 60 seconds, or until reset. Alarms are reset by placing the tank selector in the OFF position. At 90% fill level the alarm is re-activated and the fill pipe valve is closed. The valve may be opened in the manual mode up to 95%, at which point the valve is closed and disabled.