

LM1

LM1: Simplex Lube Transfer Pumps 3, 5, 10, 15, 25 GPM (12, 20, 40, 60, 100 LPM)

Compact open frame or with weatherproof enclosure. Positive displacement pump has excellent suction characteristics. Controller includes motor starter, overload relay, disconnect switch, lights for power, active, and alarm. TEFC 120-230 VAC, 50-60 Hz. Includes manual valve, check valve, strainer, inlet-outlet gauges, pressure relief valve, leak sensor, flow sensor. Controls will integrate 1-4 point level sensors for control logic.

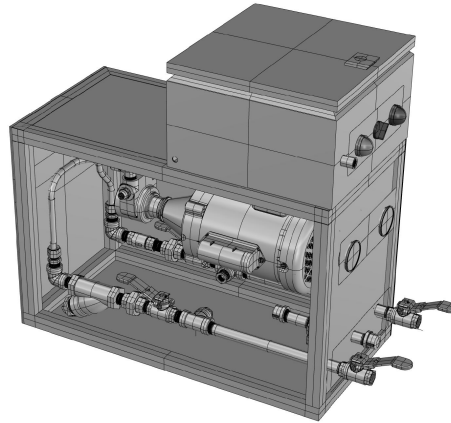

Dimensions	24"W x 24" H x 12"D (600W x 600H x 300D)
Flow Capacity	3, 5, or 10 GPM (10, 20, or 40 LPM)
Pressure Capacity	Standard 25 PSI Max. 100 PSI (690kPa)
Pump Type	Positive Displacement Viking H475 Series
Inlet / Outlet (MNPT)	3 GPM 0.50 IN (12) 5 GPM 0.50 IN (12) 10 GPM 0.75 IN (18) 15-25 GPM 1.0 IN (25)
Weight (Estimate)	150 LB (140 KG)
Standard Accessories	Inlet Strainers Outlet Check Valve Leak Sensor Inlet Suction Gauges Outlet Pressure Gauges Flow Sensor Pressure Relief Valve
Construction	Welded Steel Construction Containment Basin (3 GAL) Standard Open Frame

Motor	TEFC (IP 55)
Power	120-230 VAC, 1P, 50-60 Hz 0.33 – 1.5 HP (0.25–1.1KW)
Controller	C1 Controller Motor Overload Relay
Output Relays (Dry Contact)	Pump Auto Pump Run Pump Alarm
Interface	Man-Off-Auto Select Power ON Light Pump Run Light Pump Alarm Light
Level Sensor Inputs (Optional)	2-Point for Return Flow 4-Point for Supply Level
Optional Accessories	Floor Stand C8 Control Modbus CS Enclosure SS Enclosures 3-Phase Motor
How to Order	M1.03 Simplex 3 GPM M1.05 Simplex 5 GPM M1.10 Simplex 10 GPM