

ITEM	QTY	PART	MAKE	DESCRIPTION
1	1		CSI-MWC	UL 142 STEEL DAY TANK WITH CONTAINMENT
2	1		EARTHSAFE	ENGINE FDS-FDR CONNECTION ASSEMBLY
3	1		EARTHSAFE	REFILL CONNECTION ASSEMBLY
4	1		EARTHSAFE	RETURN FLOW PUMP ASSEMBLY
5	1		COM	DIRECT READ GAUGE
6	1	178	MOR	INSPECTION PORT FITTING
7	1	354	MOR	2" STANDARD VENT
8	1	244	MOR	4" EMERGENCY VENT
9	1	LS800	GEMS	LEVEL SENSOR - 5 POINT
10	1	LS750	GEMS	LEAK SENSOR
11	1	C800	EARTHSAFE	CONTROL PANEL
12	2	C230	EARTHSAFE	PUMP MOTOR STARTER
13	1		EARTHSAFE	PANEL SUPPORT BRACKET
14	1	475	VIKING	FUEL PUMP WITH MOTOR
15	1		EARTHSAFE	PUMP MOUNT BRACKET
16	1		EARTHSAFE	PUMP PIPE ASSEMBLY
17	1		CONBRACO	CHECK VALVE
18	1		SHARPE	BALL VALVE
19	1		EARTHSAFE	INLET VALVE ASSEMBLY BASE
20	1		EARTHSAFE	INLET VALVE ASSEMBLY HEADER
21	1-2	8210	ASCO	1 / 2" SOLENOID VALVE - NORMALLY CLOSED - 120 VAC
22	1-2	8210	ASCO	1 / 2" SOLENOID VALVE - NORMALLY OPEN
23	1-2		EARTHSAFE	STRAINER
24	2-3		SHARPE	1 / 2" BALL VALVE

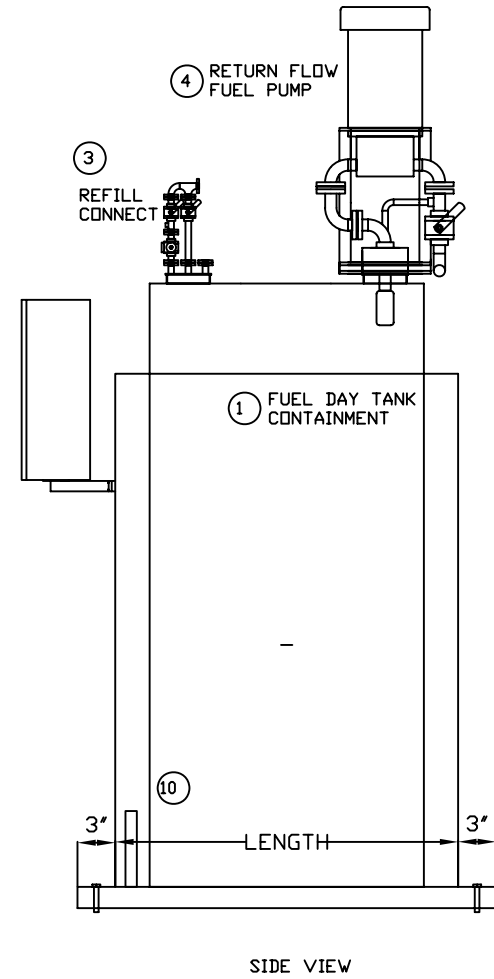
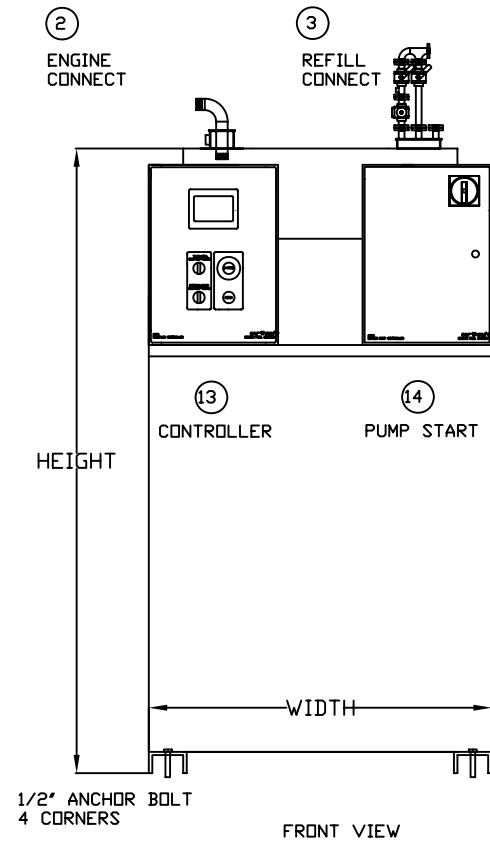
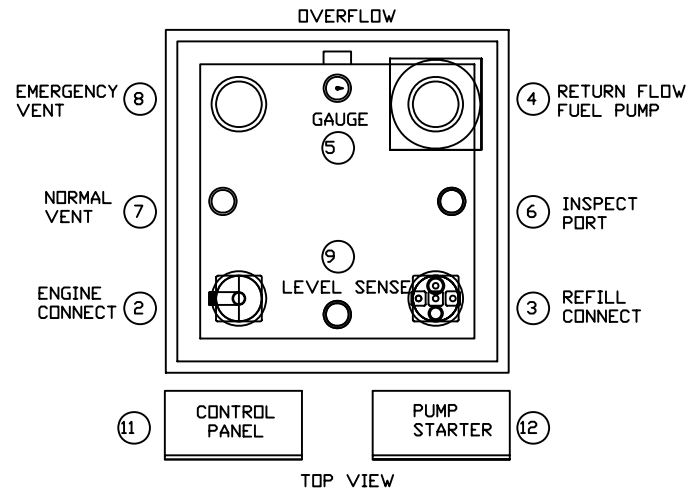

REV	DATE	BY	DESCRIPTION
A	1-1-08	BE	DESIGN DEVELOPMENT

CONFIDENTIAL

THIS DRAWING SHALL BE USED ONLY AS SPECIFIED BY CONTRACT. ANY OTHER USE, REPRODUCTION OR DISSEMINATION TO OTHERS WITHOUT WRITTEN PERMISSION IS PROHIBITED.

ENGINEER APPROVAL BY:	DATE	
DRAWN BY:	BE	DATE 1-1-08
CHECKED BY:		DATE
SCALE	AS NOTED	

CLIENT	
PROJECT TITLE	
LOCATION	

SHEET TITLE	GENERATOR DAY TANK MECHANICAL PHYSICAL		
SIZE	SHEET	NUMBER	
D	M1	ES2008-M500	

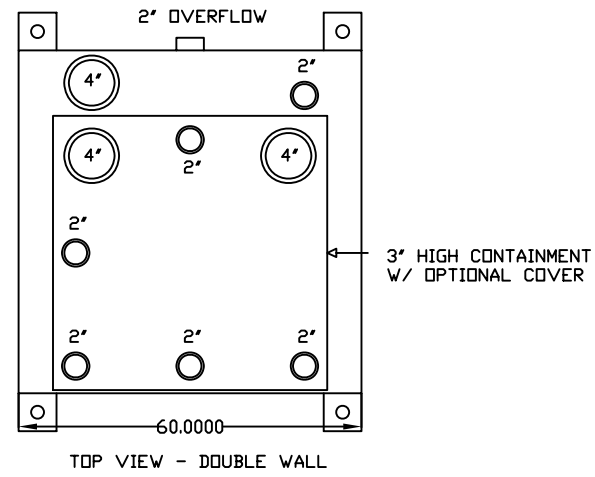
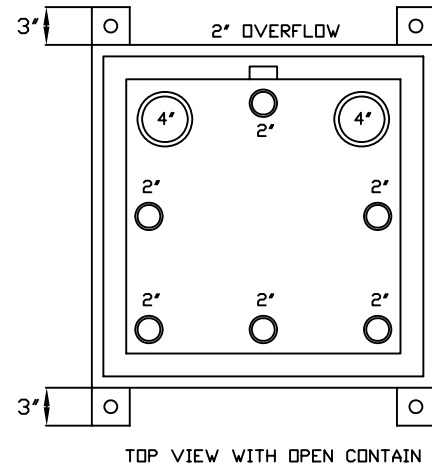

DW DAY TANK DIMENSIONS									
GAL	MAIN TANK (IN)			CONTAINMENT TANK (IN)			W/ENCL	EMPTY WT.	OPER WT.
	WIDTH	LENGTH	HEIGHT	WIDTH	LENGTH	HEIGHT	HEIGHT	LBS	LBS
50	24	24	24	26	31	33	60	250	725
100	24	24	42	26	31	51	78	450	1300
150	24	36	42	26	43	51	78	650	1875
200	24	48	42	26	55	51	78	800	2400
250	24	60	42	26	67	51	78	900	2875
300	30	48	48	32	55	57	84	1000	3350
400	30	64	48	32	71	57	84	1200	4300
500	36	70	48	38	77	57	84	1400	5250
600	36	72	54	38	79	63	90	1600	6200
700	36	84	54	38	91	63	90	1800	7150
800	48	72	54	50	29	63	90	2000	8100
900	48	84	54	50	91	63	90	2200	9050
1000	54	84	54	56	91	63	90	2400	10000

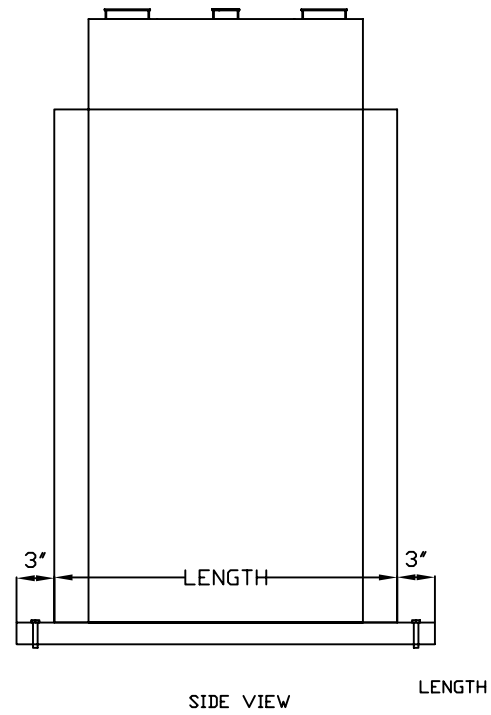
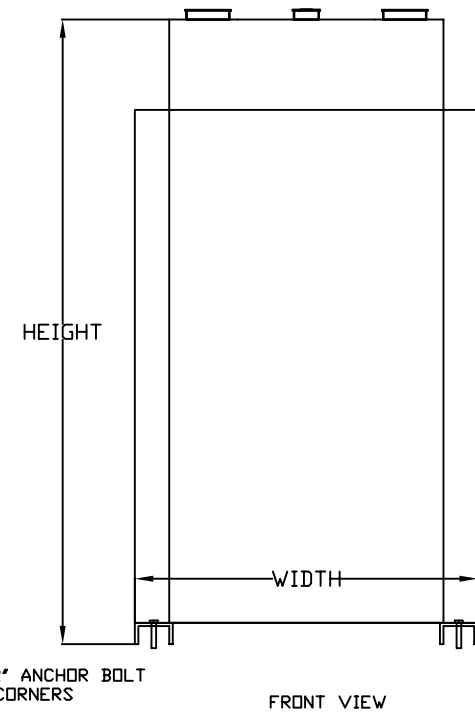

REV	DATE	BY	DESCRIPTION
A	1-1-08	BE	DESIGN DEVELOPMENT

CONFIDENTIAL

ENGINEER APPROVAL BY:	DATE	1-1-08
DRAWN BY:	DATE	
CHECKED BY:	DATE	
SCALE	AS NOTED	

CLIENT	
PROJECT TITLE	
LOCATION	

SHEET TITLE	GENERATOR DAY TANK STEEL TANK DETAILS	
SIZE	SHEET	NUMBER
D	M2	ES2008-M500

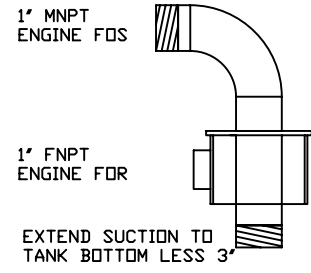

② 2" ENGINE FDS-FOR CONNECT

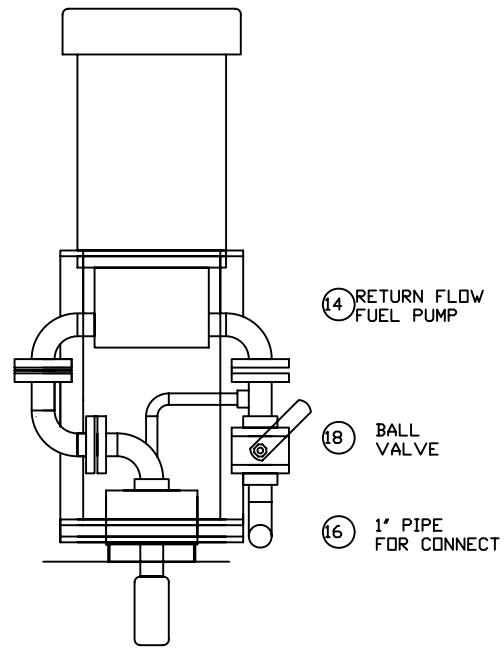

④ RETURN FLOW PUMP ASSEMBLY

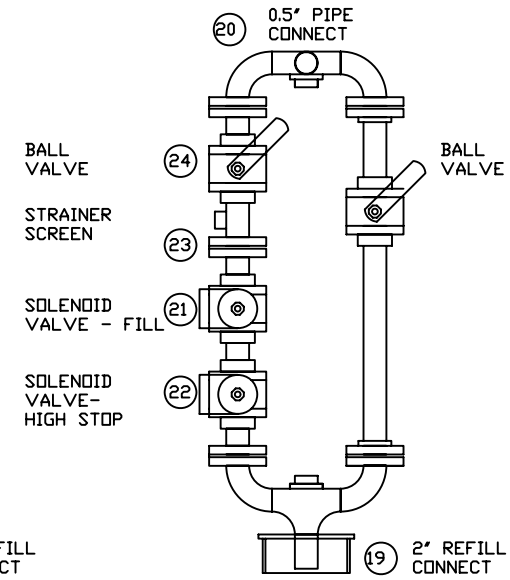
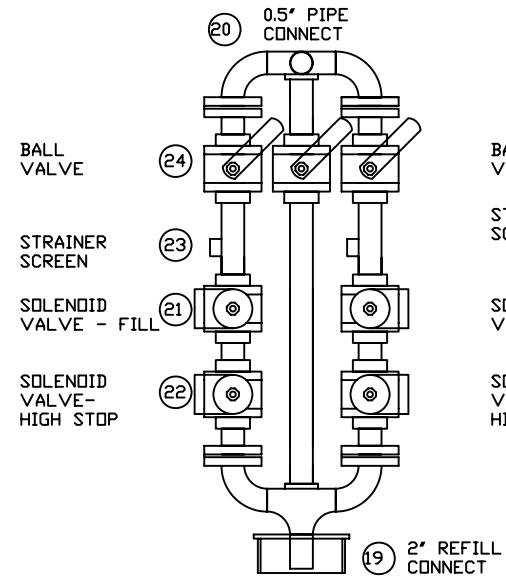
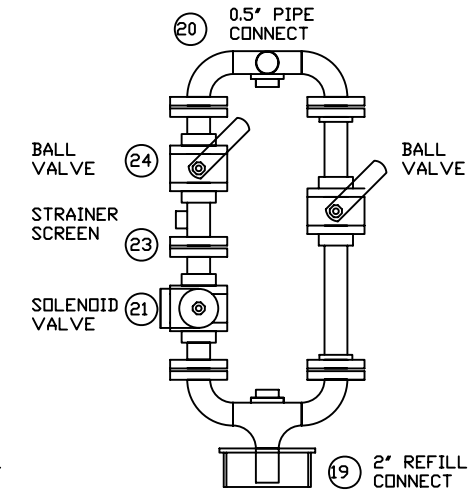
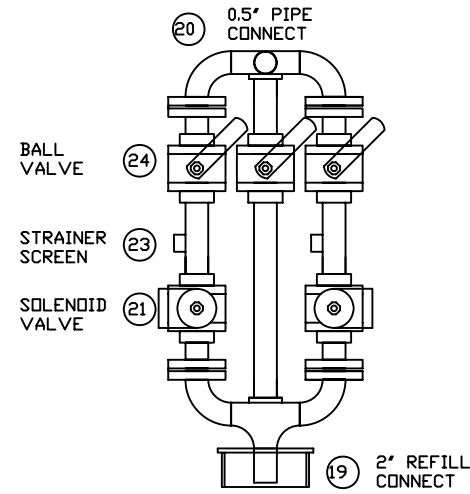

③ REFILL CONNECT

REV	DATE	BY	DESCRIPTION
A	1-1-08	BE	DESIGN DEVELOPMENT

CONFIDENTIAL

ENGINEER APPROVAL BY:	DATE	
DRAWN BY:	BE	DATE 1-1-08
CHECKED BY:		DATE
SCALE	AS NOTED	

CLIENT	
PROJECT TITLE	
LOCATION	

SHEET TITLE	GENERATOR DAY TANK MECHANICAL DETAILS		
SIZE	SHEET	NUMBER	
D	M3	ES2008-M500	

