

# earth<sup>o</sup> safe

Fuel Systems for Critical Facilities

## EMERGENCY POWER FUEL SYSTEMS

### Earthsafe FX100 Fuel Transfer Module

Earthsafe FX100 Fuel Transfer Module  
For Critical Power Systems



FX100 Fuel Transfer Containers allow for rapid global deployment of emergency power systems for data centers and other critical facilities. The FX100 Containers connect to Earthsafe T100 Tank Systems and Generator Units to provide reliable operation of power systems through extended power outages.

- ISO Container Dimensions
- Welded Steel Construction
- Dual Power Source Ready
- On-Board Power Distribution
- Redundant Mechanical Systems
- Redundant PLC Control
- Full Secondary Containment
- Bulk Tank Fuel Volume and Leak Monitoring
- On-Board Heating, Ventilation, and Lighting
- Fully Integrated Systems using Modbus, BACnet, or LON

<b>Functional Description</b> <b>FX 100 Fuel Transfer Module (Gen Sub-base Tank)</b> <b>FX 200 Fuel Transfer Module (Integral Day Tanks)</b>	
Fuel Receipt – Tank Fill Station	<p>Receive fuel from delivery trucks and transfer fuel to bulk storage tanks or generator base tanks.</p> <p>300 GPM (1100 LPM) Centrifugal Pump and Motor, Motor starter disconnect, Control panel with tank selection, high level alarms, level gauging. Inlet basket strainer. 1-6 Actuated ball valves for tank selection.</p>
Filtration Polishing And Tank Transfer	<p>Re-circulate and filter polish fuel from bulk storage tanks</p> <p>30 GPM (100 LPM) Pump and Motor, Motor starter disconnect, Filter vessel with coalescing and particulate filters. Biocide tank and metering pump, Filter water tank and pump. Control panel with tank selection, filter monitoring, pump control. Actuated ball valves for 1-6 tank selection.</p> <p>Allows valve alignment for transfer between bulk storage tanks.</p>
Triplex Pump Gen Tank Refill	<p>Transfer fuel from bulk storage tanks to generator base tanks or day tanks</p> <p>Triplex 25 GPM (90 LPM) Pump and Motor, Motor starter disconnect, Inlet basket strainers. Control panel with tank selection and pump control. Actuated ball valves for 1-6 tank selection of fuel supply. Integrates gen tank level sensors and inlet control valves for 1-6 generators.</p>
Integral Day Tanks For FX200	<p>Individual 100 GAL (400 L) UL 142 steel day tanks for each Generator</p> <p>Steel day tanks with dual inlet control valves, inlet flow regulators, level – leak – temperature sensors. Return flow pumps and motor starters or overflow receipt tank with duplex pumps. Engine FOS and FOR connections. Standard and emergency vents. Control panel for tank level control and monitoring.</p>

**FX100 Fuel Transfer Module  
Generator Sub-Base Tanks**

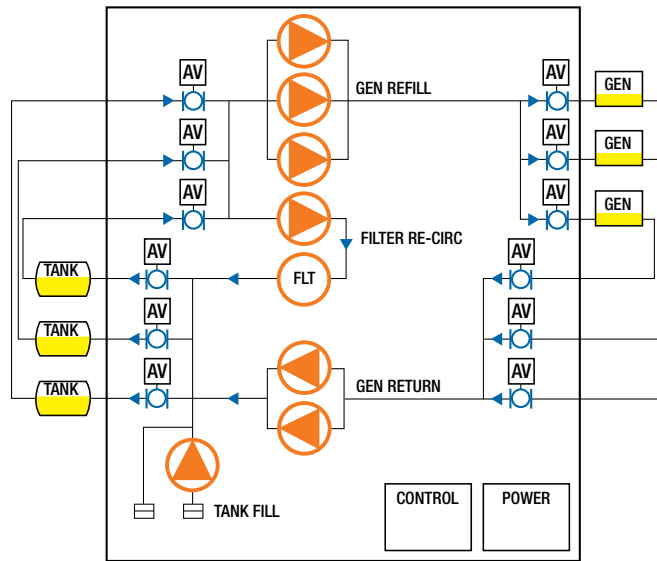

**FX 200 Fuel Transfer Module  
Integral Day Tanks**

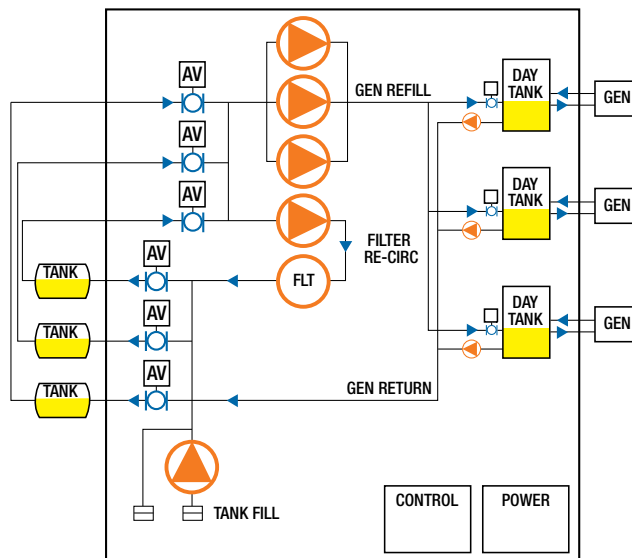

FX100 / FX200 Specifications	
Dimensions	8 FT H x 8 FT W x 20 FT L (2438 x 2438 x 6096) for 1-3 Generators 8 FT H x 8 FT W x 40 FT L (2438 x 2438 x 12192) for 4-6 Generators
Enclosure	Welded Steel Construction Epoxy Coating Inside and Out Integral Spill Containment with Leak Detection Fan, Heater, and Light
Fuel Transfer Pumps	Viking Positive Displacement Iron Body Pump Close Coupled TEFC Motor 480 VAC / 3 Phase / 50-60 Hz 0.75 HP (0.55 KW, 1140 RPM High Suction 25 GPM (90 LPM) Duplex Fuel Transfer 30 GPM (100 LPM) Gen Tank Overflow Pump 30 GPM (100 LPM) Filter Polisher
Fuel Receipt Pump	Gorman Rupp Centrifugal Pump Close Coupled TEFC Motor 480 VAC / 3 Phase / 50-60 Hz 3 HP (2.25 KW) 300 GPM (1100 LPM)
Accessories	Bypass Relief Valve Adjustable Inlet Vacuum Gauge Outlet Pressure Gauge Inlet Strainers Inlet Check Valve Inlet and Outlet Ball Valves Leak Sensor
Inlet / Outlet Connections	FOS-FOR 3 IN (75mm) Flange to Bulk Tanks FOS-FOR 1.5 IN (38mm) Flange to Generator Tanks
Controls	C900 CentraPlexPlex Controller Dual Power Feed Dual PLC Graphic Interface BMS Interface: Modbus, BACnet, LON
Motor Disconnect / Drives	Disconnect Switch Motor Starter Overload Protection Current Sensor HOA Switch MAN start on line power
Power Requirements	480 VAC – 3 Phase – 20 Amp Dual Power Feed Integral Auto Transfer Switch
Ordering Information	<b>FX100-XY Fuel Transfer Module</b> <b>FX200-XY Fuel Transfer Module (Day Tanks)</b>  X = Number of Bulk Storage Tanks Y = Number of Generators