

Vacuum Sensors

Installation Guide

Notice

Veeder-Root makes no warranty of any kind with regard to this publication, including, but not limited to, the implied warranties of merchantability and fitness for a particular purpose.

Veeder-Root shall not be liable for errors contained herein or for incidental or consequential damages in connection with the furnishing, performance, or use of this publication.

Veeder-Root reserves the right to change system options or features, or the information contained in this publication.

This publication contains proprietary information which is protected by copyright. All rights reserved. No part of this publication may be photocopied, reproduced, or translated to another language without the prior written consent of Veeder-Root.

DAMAGE CLAIMS / LOST EQUIPMENT

Thoroughly examine all components and units as soon as they are received. If any cartons are damaged or missing, write a complete and detailed description of the damage or shortage on the face of the freight bill. The carrier's agent must verify the inspection and sign the description. Refuse only the damaged product, not the entire shipment.

VEEDER-ROOT'S PREFERRED CARRIER

1. Contact VR Customer Service at 800-873-3313 with the specific part numbers and quantities that were missing or received damaged.
2. Fax signed Bill of Lading (BOL) to VR Customer Service at 800-234-5350.
3. VR will file the claim with the carrier and replace the damaged/missing product at no charge to the customer. Customer Service will work with production facility to have the replacement product shipped as soon as possible.

CUSTOMER'S PREFERRED CARRIER

1. It is the customer's responsibility to file a claim with their carrier.
2. Customer may submit a replacement purchase order. Customer is responsible for all charges and freight associated with replacement order. Customer Service will work with production facility to have the replacement product shipped as soon as possible.
3. If "lost" equipment is delivered at a later date and is not needed, VR will allow a Return to Stock without a restocking fee.
4. VR will NOT be responsible for any compensation when a customer chooses their own carrier.

RETURN SHIPPING

For the parts return procedure, please follow the appropriate instructions in the "General Returned Goods Policy" and "Parts Return" pages in the "Policies and Literature" section of the Veeder-Root **North American Environmental Products** price list.

WARRANTY

Please see next page, iii.

Warranty

TLS-350R, TLS-350 PLUS, TLS-350J AND TLS-300I/C, AND TLS-2 MONITORING SYSTEMS.

We warrant that this product shall be free from defects in material and workmanship for a period of one (1) year from the date of installation or twenty-four (24) months from the date of invoice, whichever occurs first. During the warranty period, we or our representative will repair or replace the product, if determined by us to be defective, at the location where the product is in use and at no charge to the purchaser. **LAMPS AND FUSES ARE NOT COVERED UNDER WARRANTY.**

We shall not be responsible for any expenses incurred by the user.

This warranty applies only when the product is installed in accordance with Veeder-Root's specifications, and a Warranty Registration and Checkout Form has been filed with Veeder-Root by an authorized Veeder-Root Distributor. This warranty will not apply to any product which has been subjected to misuse, negligence, accidents, systems that are misapplied or are not installed per Veeder-Root specifications, modified or repaired by unauthorized persons, or damage related to acts of God.

If "Warranty" is purchased as part of the Fuel Management Service, Veeder-Root will maintain the equipment for the life of the contract in accordance with the written warranty provided with the equipment. A Veeder-Root Fuel Management Services Contractor shall have free site access during Customer's regular working hours to work on the equipment. Veeder-Root has no obligation to monitor federal, state or local laws, or modify the equipment based on developments or changes in such laws.

ILS-350 MONITORING SYSTEMS

We warrant that this product shall be free from defects in material and workmanship for a period of one (1) year from the date of installation or twenty-four (24) months from the date of invoice, whichever occurs first. During the first ninety (90) days, we or our representative will repair or replace the product, if determined by us to be defective, at the location where the product is in use and at no charge to the purchaser. After the first ninety (90) days of the warranty period, we will repair or replace the product if it is returned to us, transportation prepaid, within the warranty period and is determined by us to be defective. We will not be responsible for any shipping expenses incurred by the user. **LAMPS AND FUSES ARE NOT COVERED UNDER WARRANTY.**

This warranty applies only when the product is installed in accordance with Veeder-Root's specifications, and a Warranty Registration and Checkout Form has been filed with Veeder-Root by an Authorized Veeder-Root Distributor. This warranty will not apply to any product which has been subjected to misuse, negligence, accidents, systems that are misapplied or are not installed per Veeder-Root specifications, modified or repaired by unauthorized persons, or damage related to acts of God.

MODULES, KITS, OTHER COMPONENTS (PARTS PURCHASED SEPARATE OF A COMPLETE CONSOLE).

We warrant that this product shall be free from defects in material and workmanship for a period of fifteen (15) months from date of invoice. We will repair or replace the product if the product is returned to us; transportation prepaid, within the warranty period, and is determined by us to be defective. This warranty will not apply to any product which has been subjected to misuse, negligence, accidents, systems that are misapplied or are not installed per Veeder-Root specifications, modified or repaired by unauthorized persons, or damage related to acts of God.

We shall not be responsible for any expenses incurred by the user.

Introduction

Before You Begin 1
 Hardware Requirements 1
 Available Kits 1
 Safety Precautions 2

Installation

Overview 4
 Field Assembling Vac Sensor/Vac Float modules 5
 Installing Vac Sensor Housing Support Bracket 8
 Attaching Vac Sensor Cables and Tagging Vac Sensor/Vac Float Pairs 9
 Installing Vac Sensor Housing onto Support Bracket 10
 Vacuum Connections within Sump 10
 Vacuum Connections to a Double-Wall Product Line..... 10
 Vacuum Connections to a Double-Wall Vapor Return Line..... 10
 Vacuum Connections to a Double-Wall Sump 11
 Vacuum Connections to a Double-Wall Steel Tank..... 11
 Vacuum Connections to a Double-Wall Fiberglass Tank 12
 Vacuum Connections to Siphon Port of the Pump 13
 Field Wiring Vac System Connections 14
 Connecting Vac Sensor Field Wiring to TLS Console 16
 Connecting Pump Control Field Wiring to TLS Console 16
 For Sites with PLLD or WPLLD Leak Detection 16
 For Sites without PLLD or WPLLD Leak Detection 16
 Disable Extended Run Feature in the Pump Controller 18

Vac System Testing

ATM Pressure Sensor Setup 19
 Vac Sensor Setup 20
 Identifying Vac Sensor Zones..... 20
 Performing Vac Sensor Setup 22
 Vacuum Integrity Test Prior to Filling Tank (Optional) 23
 Running a Manual Test 24
 Perform the Manual Test for Each Vac Sensor 24
 Vacuum Sensor Operability Test - Required for Each Sensor Prior to Startup 24

Appendix A: Vac Sensor Test Values Record A-1

Figures

Figure 1.	Installation example of Four Vac Sensor w/tank interstitial monitoring	4
Figure 2.	Vac Sensor Assembly Dimensions	5
Figure 3.	Attaching four Vac Sensors/Floats to the housing	6
Figure 4.	Vac Sensor/Vac Float tubing connections.....	7
Figure 5.	Vac Sensor /tank interstice tubing connections.....	7
Figure 6.	Attaching vacuum tubing between Vac Sensors.....	8
Figure 7.	Attaching Vac Sensor housing support bracket	8
Figure 8.	Identifying Vac Sensor/Vac Float pairs	9
Figure 9.	Attaching Vac Sensor housing to support bracket	10
Figure 10.	Example vacuum termination fitting - double-wall pipe	11
Figure 11.	Example tank interstitial sensor riser cap connections - steel and fiberglass tanks.....	12
Figure 12.	Attaching 1/4" tubing to STP siphon cartridge.....	13
Figure 13.	Connecting vacuum tubing from pump siphon port to Vac Sensor system	13
Figure 14.	Field wiring connections	14
Figure 15.	Epoxy sealing wiring connections	15
Figure 16.	Attaching Vac Sensors to Smart Sensor / Press Module.....	16
Figure 17.	Connecting Pump Sense & 4-Relay Modules - Red Jacket Pumps.....	17
Figure 18.	Connecting Pump Sense & 4-Relay Modules - Non-RJ Pumps.....	18
Figure 19.	TLS Console Vac Sensor Manual Test	25
Figure 20.	TLS Console Vac Sensor Evac Hold Procedure	26

Introduction

These instructions describe the installation of Veeder-Root Vacuum sensors in a STP sump to monitor the interstitial space of:

- Double-wall product lines
- Double-wall vapor return lines
- Double-wall tank vent lines
- Double-wall tanks
- Double-wall sumps

Before You Begin

Prior to backfilling the tank top (i.e. covering the lines, UDC, tank sumps) the contractor is strongly advised to test the interstices for leaks, and to monitor the vacuum during the backfill process.



CAUTION: Do not exceed equipment manufacturer's recommended vacuum levels!

NOTE: While it is common practice to use an independent vacuum source to provide the initial vacuum, you must ensure that pump lubricating oil and any other foreign substance is not introduced into the SCVS system. Failure to do so may damage the SCVS system and will void warranty.

Hardware Requirements

- TLS-350/350R with version 24C or later software
- At least one SmartSensor/Press Module
- Line leak (PLLD or WPLLD), or w/o line leak, a Pump Sense and a 4-Relay module is required for STP control
- STP siphon port
- Siphon Check Valve (V-R P/N 188-241-5)
- Schraeder Fitting 576008-672 (optional)
- Siphon manifolded tank requirements:
 - The Red Jacket STP requires a secondary siphon assembly (V-R P/N 410071-002).
 - The Quantum STP comes with two siphons as standard equipment - no additional parts are required.
 - FE pumps require a secondary siphon kit (FE P/N 402-507-930).

Available Kits

Vac sensor kits are available in several configurations:

1, 2, 3, or 4 Vac Sensor/Vac Float pre-assembled kits - includes mounting hardware, tubing/connections, and cables (for one sump)









- 1 Vac Sensor kit w/steel float, 2 Vac Sensor kit w/steel float, 3 Vac Sensor kit w/steel float, or 4 Vac Sensor kit w/steel float
- 2, 3, or 4 Vac Sensor kit w/fiberglass 4', 6', 8', or 10' float (includes relief valve)
- 2, 3, or 4 Vac Sensor kit w/o tank interstitial sensor
- 1 Vac Sensor kit w/o tank interstitial sensor

Individual kits (requires Vac Sensor/Vac Float field assembly)

- Mounting kit - 1 required per sump
- Secondary piping vacuum monitoring kit - 1 each required for product line, vapor recovery line, or sump interstice monitoring -includes mounting hardware, tubing/connections, and cables
- Interstitial sensor kit for steel tank - includes Vac Sensor, mounting hardware, tubing/connections, riser cap, 3-way valve and cables
- 4', 6', 8', or 10' diameter fiberglass tank Interstitial sensor kit - includes Vac Sensor, mounting hardware, tubing/connections, riser cap, relief valve, 3-way valve and cables. NOTE: you do not need to order an additional relief valve for a fiberglass tank installation.

Safety Precautions

The following safety symbols are used throughout this manual to alert you to important safety hazards and precautions.

 <p>EXPLOSIVE Fuels and their vapors are extremely explosive if ignited.</p>	 <p>FLAMMABLE Fuels and their vapors are extremely flammable.</p>
 <p>ELECTRICITY High voltage exists in, and is supplied to, the device. A potential shock hazard exists.</p>	 <p>TURN POWER OFF Live power to a device creates a potential shock hazard. Turn Off power to the device and associated accessories when servicing the unit.</p>
 <p>WARNING Heed the adjacent instructions to avoid equipment damage or personal injury.</p>	 <p>INJURY Careless or improper handling of materials can result in bodily injury.</p>
 <p>WEAR EYE PROTECTION Wear eye protection when working with pressurized fuel lines or epoxy sealant to avoid possible eye injury.</p>	 <p>GLOVES Wear gloves to protect hands from irritation or injury.</p>
 <p>READ ALL RELATED MANUALS Knowledge of all related procedures before you begin work is important. Read and understand all manuals thoroughly. If you do not understand a procedure, ask someone who does.</p>	

⚠ WARNING

This product operates in the highly combustible atmosphere of a gasoline storage tank. Failure to follow all instructions in proper order can cause personal injury or death.

1. To be installed in accordance with the National Electrical Code, NFPA 70 and the Automotive And Marine Service Station Code, NFPA 30A.
2. Turn off, tag, and lockout power to the STP before connecting or servicing wiring to the STP.
3. Do not modify or use service parts other than those provided by Veeder-Root.
4. Substitution of components may impair intrinsic safety.
5. To protect yourself and others from serious injury, death, or substantial property damage, carefully read and follow all warnings and instructions in this manual.

Installation

Overview

A simplified Veeder-Root vacuum sensor installation in an STP sump is shown in Figure 1. Vac Sensor (VS) and Vac Float (VF) modules are assembled in a housing which is shown in Figure 2. A separate mounting bracket (see Figure 2) is easily attached to the STP riser to support the Vac Sensor housing. Approximately 12 inches of clearance is required below the pump manifold for the Vac Sensor components. Final vacuum connections are made once the housing and bracket are in place. A 1/4" NPT port into the interstitial space of the double-wall vapor return line, double-wall product line, and/or double-wall sump must be accessible in the sump. For installations requiring tank interstice monitoring, a riser must be in the same sump for the tank interstitial sensor. Field wiring connections of the Vac Sensor components are sealed in a customer supplied sump junction box (JB).

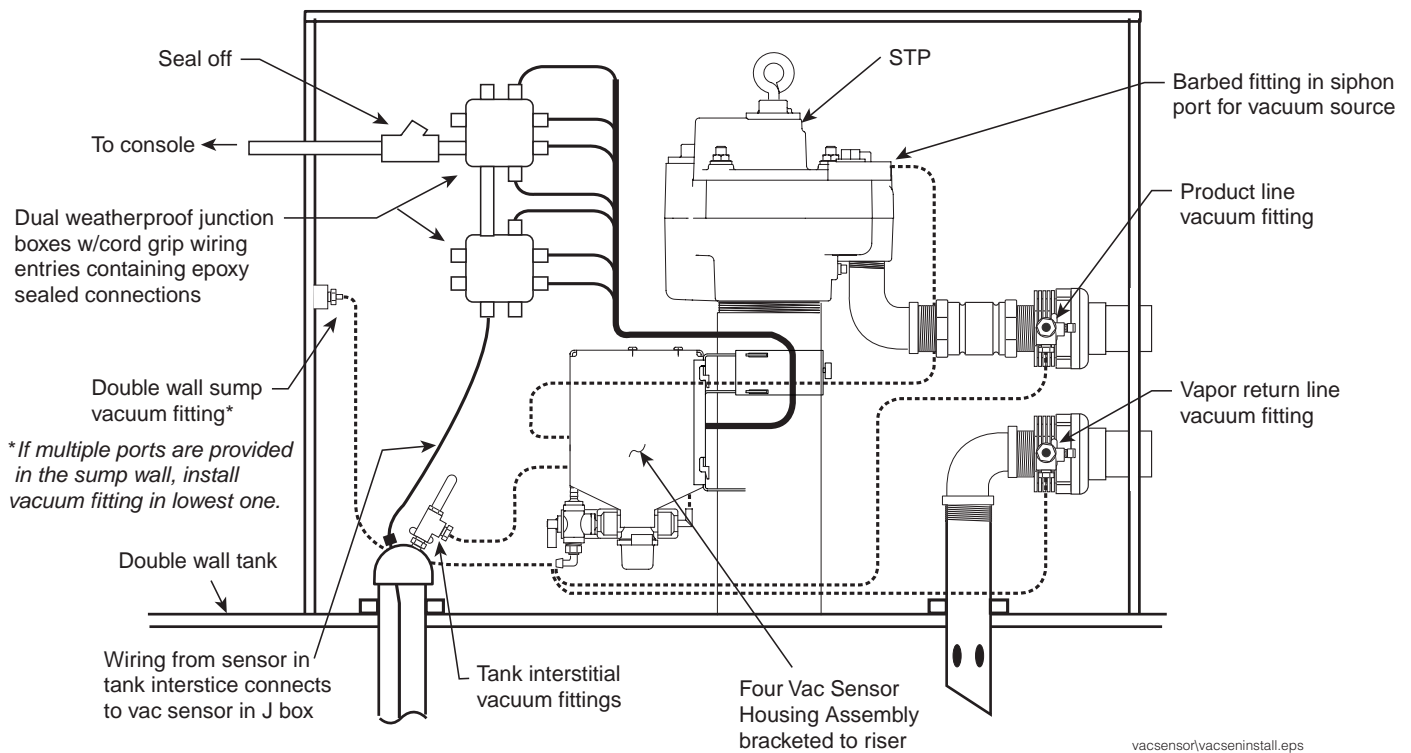

Figure 1. Installation example of Four Vac Sensor w/tank interstitial monitoring



CAUTION! Use only the materials specified in this manual during installation. Use of any other materials or lubricants may damage the SCVS system and will void warranty. Lubricate fittings only with soapy water - do not use any other materials.

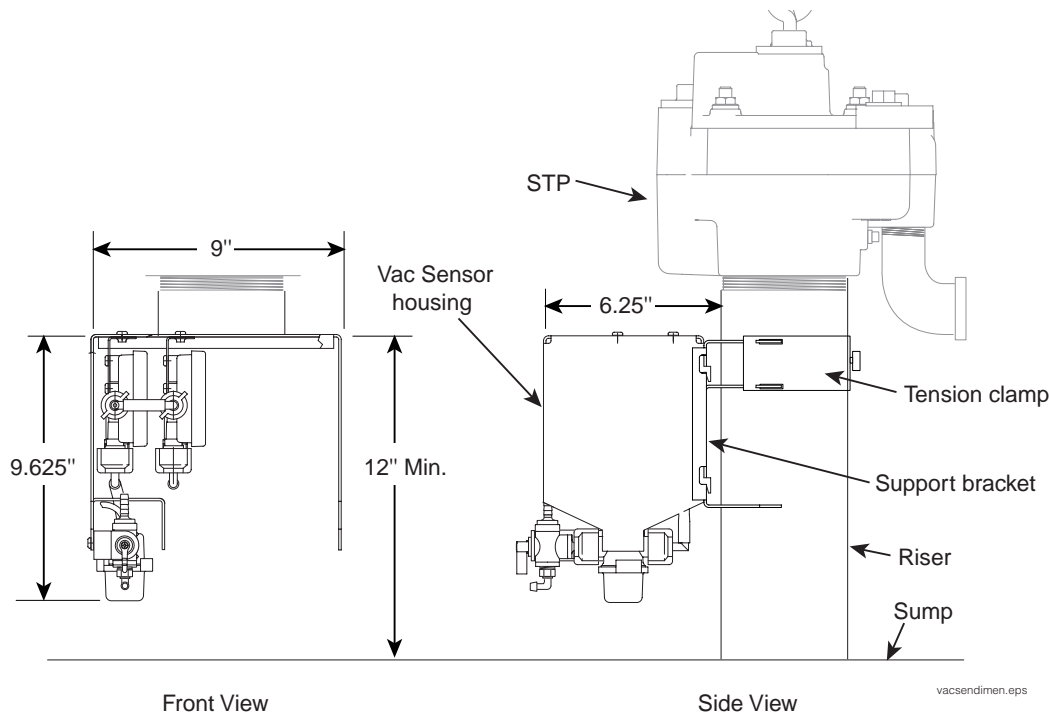

Figure 2. Vac Sensor Assembly Dimensions

Field Assembling Vac Sensor/Vac Float modules

If you are field assembling the Vac Sensor/Vac Floats into the Vac Sensor housing continue to Step 1. If you are installing the pre-assembled 2, 3, or 4 Vac Sensor kit go to "Installing Vac Sensor Housing Support Bracket" on page 8.

1. Get the Vac Sensor modules and brackets from each of the secondary piping vacuum monitoring kits. If a tank interstice is being monitored, also get the Vac Sensor module and bracket from that kit.
2. Get the Vac Sensor housing from the mounting kit and attach each of the Vac Sensors (up to 4) to the top of the housing using #10 x 3/8" self-tapping screws as shown in Figure 3. Mount the Vac Sensors with the 'STP Siphon' labeled port facing the front of the housing.
3. For Vac Sensors requiring Vac Floats, continue to Step 4. For the Vac Sensor monitoring the tank interstice skip to step.
4. Get the Vac Floats, support brackets, plastic valves and #10 x 1/2" self-tapping screws from the secondary piping vacuum monitoring kits.

If you are not monitoring a tank interstice, there is a maximum of two left-hand Vac Sensor/Float mounting positions and two right-hand Vac Sensor/Float mounting positions in the Vac Sensor Housing (Figure 3). If a tank interstice is being monitored, then one of the four Vac Sensors will have no Vac Float attached.

5. Get the plastic valves, barbed elbows, tapered bushings and cord grip nuts from the Vac Float kits. Insert bushings and screw cord grip nuts into the two ports of the Vac Float. Insert a valve into one port and a barbed elbow into the other port of each Vac Float. Orient elbow and valves in Vac Floats as shown in Figure 4 then tighten nuts to secure the fittings.

- Get the angled support brackets from each Vac Float kit. Depending on the Vac Float's position in the housing, orient the bracket so that when you slip the large hole in the front of the bracket over the valve handle, the two holes in the side of the bracket are in line with the two holes in the side of the Vac Float body as shown in Figure 3. Secure the Vac Float assembly to the housing using two #10 x 1/2" self-tapping screws which screw into the two holes in the side of the Vac Float.

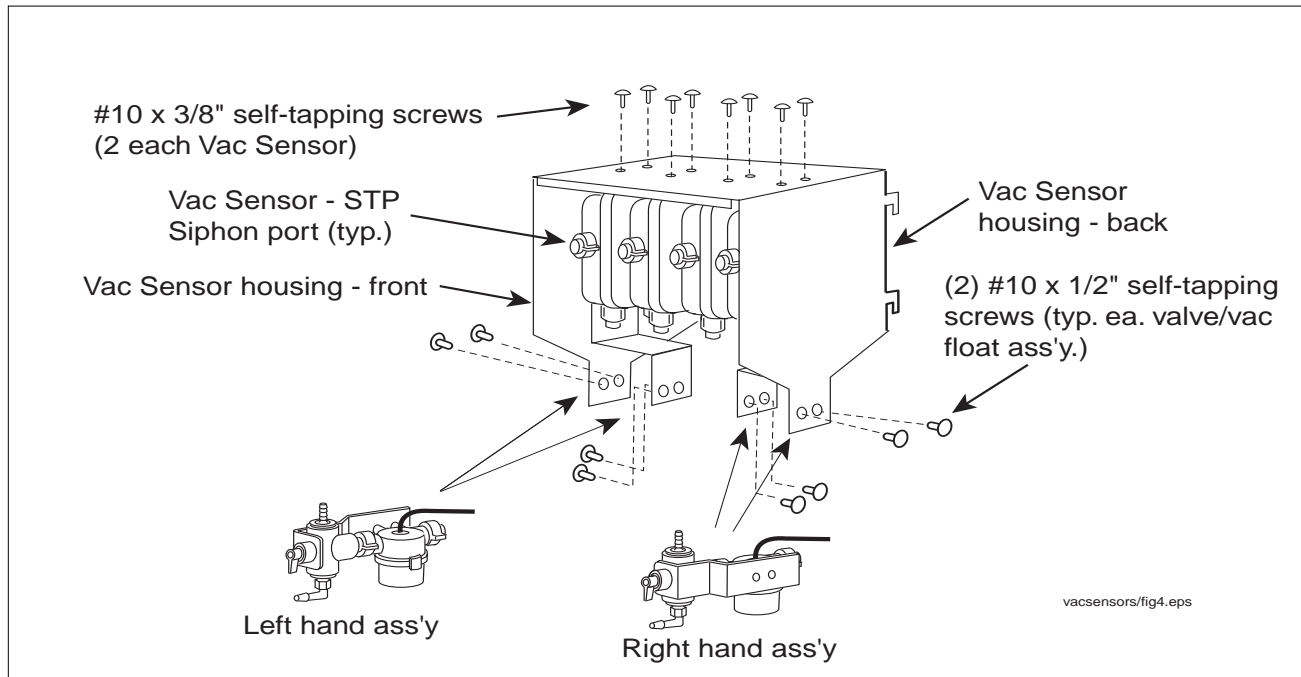

Figure 3. Attaching four Vac Sensors/Floats to the housing

- Get barbed elbows, tapered bushings and cord grip nuts (1 each for each Vac Sensor) from the secondary piping vacuum monitoring kits. Insert a tapered bushing and barbed elbow in the bottom port labeled VAC TEST (embossed on cover) of one of the Vac Sensors. Orient the elbows as shown in the Figure 4, then tighten the cord grip nut.
- From the kit's 1/4" tubing, cut a piece of the 1/4" tubing and connect the VAC TEST port in one of the Vac Sensors to the rear elbow fitting in one of the Vac Floats (preferably the one under it). Keep the connection kink free and as short as possible (see Figure 4). Repeat this procedure for each additional Vac Sensor/Vac Float pair. Skip to Step 10.
- If the tank interstice is monitored, get a barbed elbow, tapered bushing and cord grip nut (1 each) from the Vac Sensor tank interstice monitoring kit. Insert a tapered bushing and barbed elbow into the bottom port labeled VAC TEST (embossed on cover) of the Vac Sensor without a Vac Float. Orient the elbow as shown in the Figure 5, then tighten the cord grip nut.
- Get the barbed tees, tapered bushings, cord grip nuts and one barbed elbow from the vacuum monitoring kits.
- Looking at the front of the Vac Sensor housing, insert the elbow in the side vacuum port bushing labeled 'STP Siphon' (on the Vac Sensor cover) in the Vac Sensor closest to the side of the housing. Orient the elbow so that the open half is horizontal and pointing to the other Vac Sensors (see Figure 7). Insert a tee in the same vacuum port in each of the other Vac Sensors. Orient the tees in the horizontal position, except the Vac Sensor closest to the other side of the Vac Sensor housing. Remove this tee and orient it so that one end points toward the other tees and one end points out at you then insert the inlet end into the bushing. Measure and cut a piece of the tubing approximately 1-3/4" long to connect each of the tees and elbow as shown in

Figure 7. Once the tubing pieces are cut, remove the barbed elbows and tees to push on the tubing pieces, then reinsert this connected assembly back into the Vac Sensor bushings and tighten the nuts.

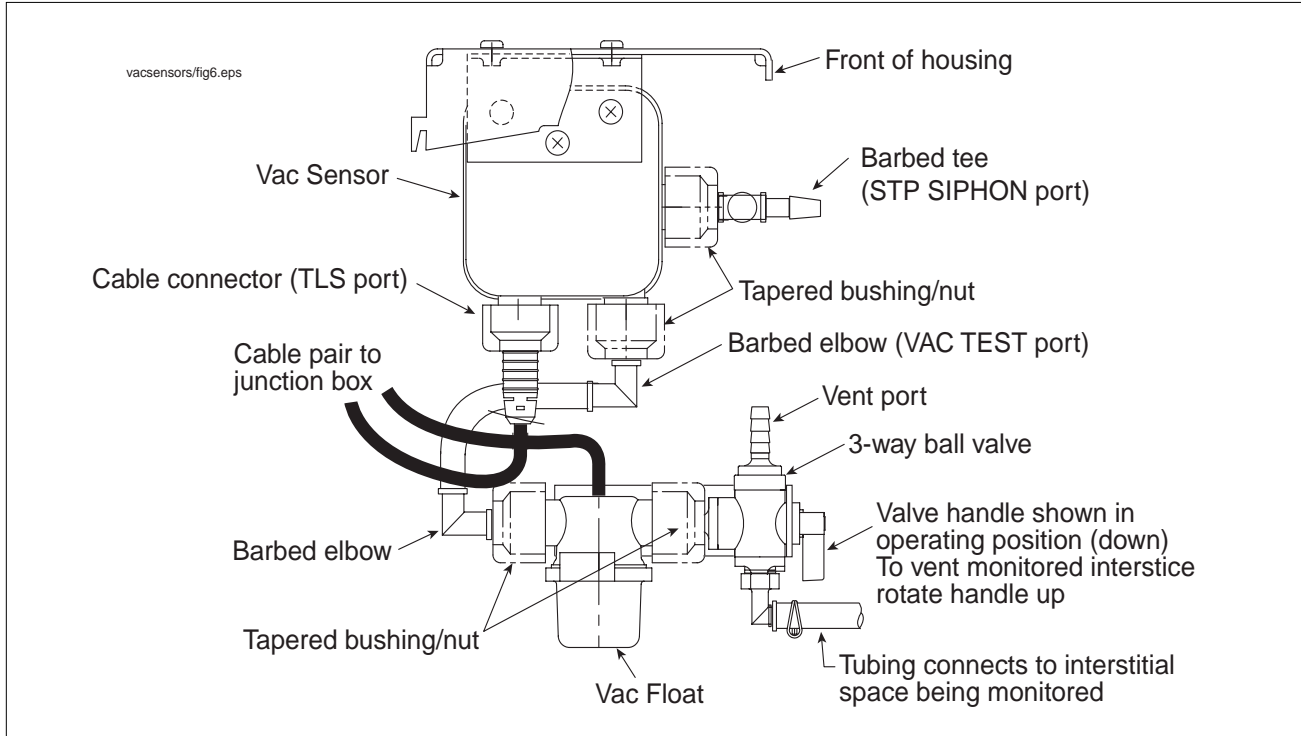

Figure 4. Vac Sensor/Vac Float tubing connections

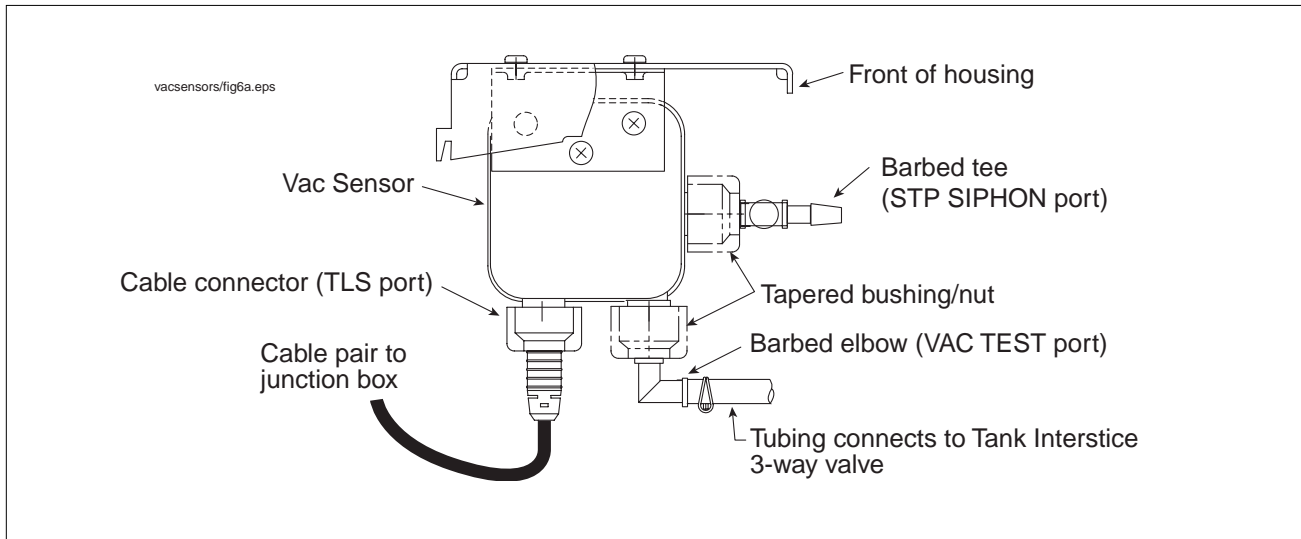

Figure 5. Vac Sensor /tank interstice tubing connections

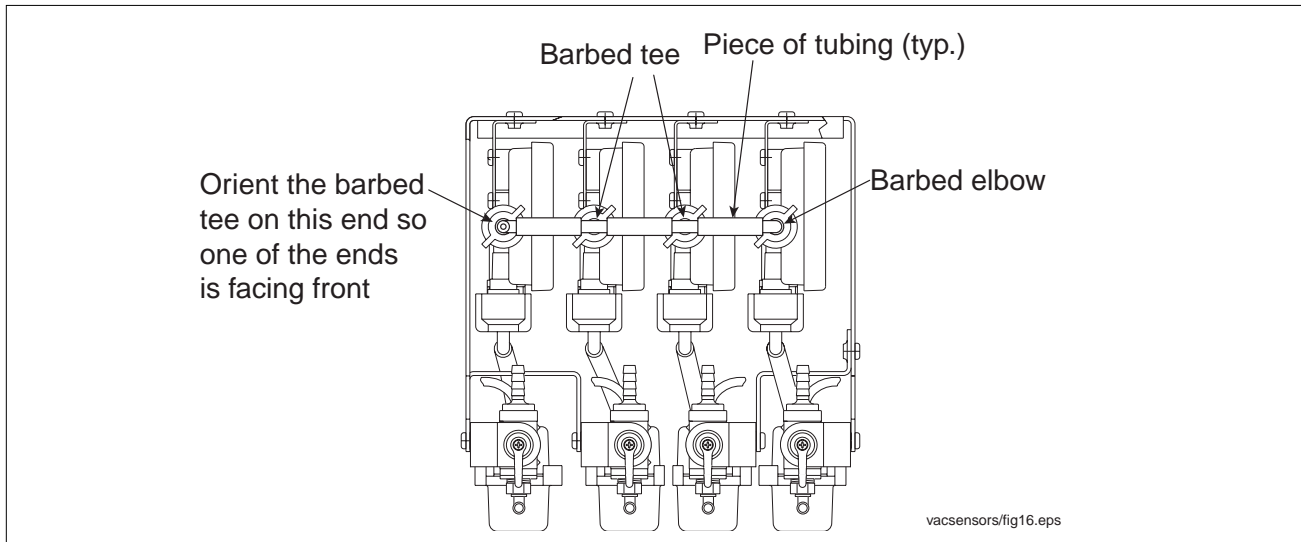

Figure 6. Attaching vacuum tubing between Vac Sensors (In this example there is no Tank monitoring)

Installing Vac Sensor Housing Support Bracket

Get the Vac Sensor housing support bracket and the curved tensioning clamp from the mounting kit. Hold the bracket against the STP riser. Place the curved clamp around the back of the riser and hook the four notches in the clamp over the four barbs in the top of the bracket (see Figure 7). Position the bracket so the top of bracket is at least 12 inches above the sump floor and hand tighten the tension adjust knob on the back of the clamp until the assembly is secure.

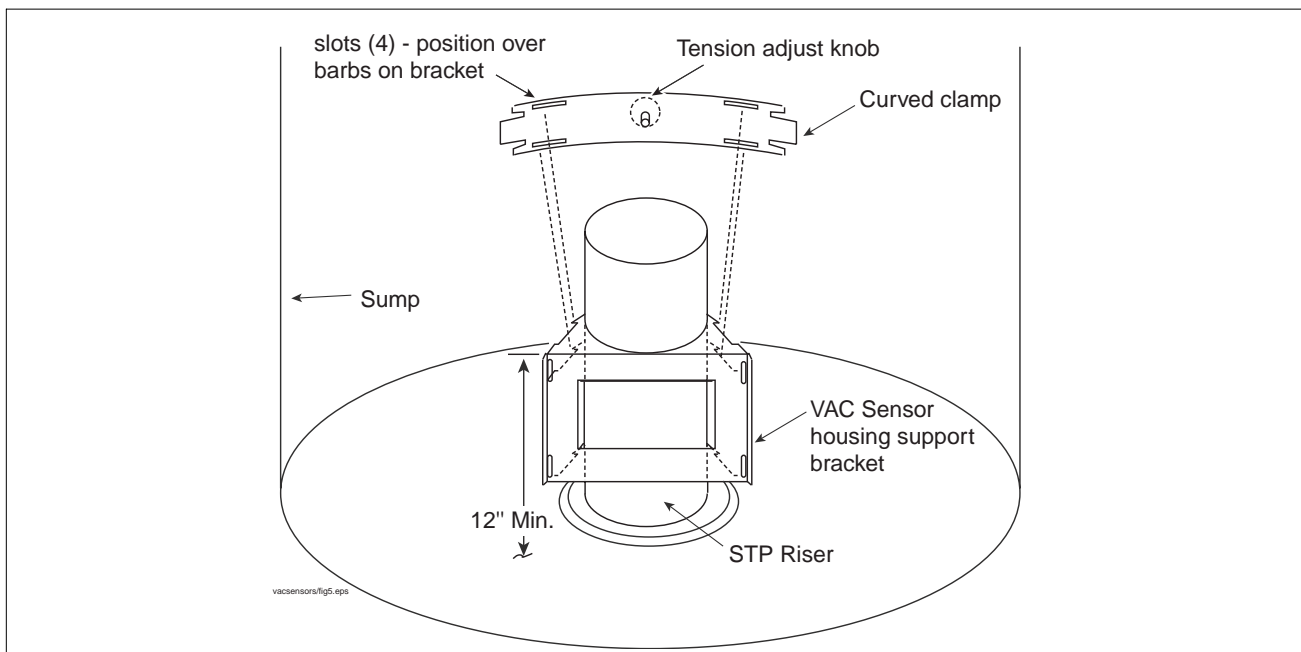

Figure 7. Attaching Vac Sensor housing support bracket

Attaching Vac Sensor Cables and Tagging Vac Sensor/Vac Float Pairs

1. Next get the Vac Sensor cables (with connectors on one end) from the kit(s) and attach the connector of each cable to each of the Vac Sensor ports labeled TLS (on the Vac Sensor cover). Uncoil each of the Vac Float cables. Notice that each Vac Sensor, except the one for the tank interstice, has a short piece of tubing connecting it to a Vac Float beneath it (Figure 8). A Vac Sensor/Vac Float tubing connected pair must be wired together in the junction box.
2. Use a felt pen and write on the top of the Vac Sensor housing to what device each of the Vac Sensors below will be attached (see Figure 9). For example, P = product line, S = sump interstice, V = vapor line, and T = tank interstice. NOTE: If the mark you wrote on the housing over the first Vac Sensor was 'P', locate the cable ends of this Vac Sensor/Vac Float pair, tape them together about every foot along their length and at their ends, and tag the end of this cable pair 'P' or 'Product Line Vac Sensor'. Repeat this taping and tagging for each of the Vac Sensor/Vac Float pairs. The Vac Sensor marked 'T' will only have one cable, so tag the end of this cable 'T' for 'Tank Vac Sensor'.

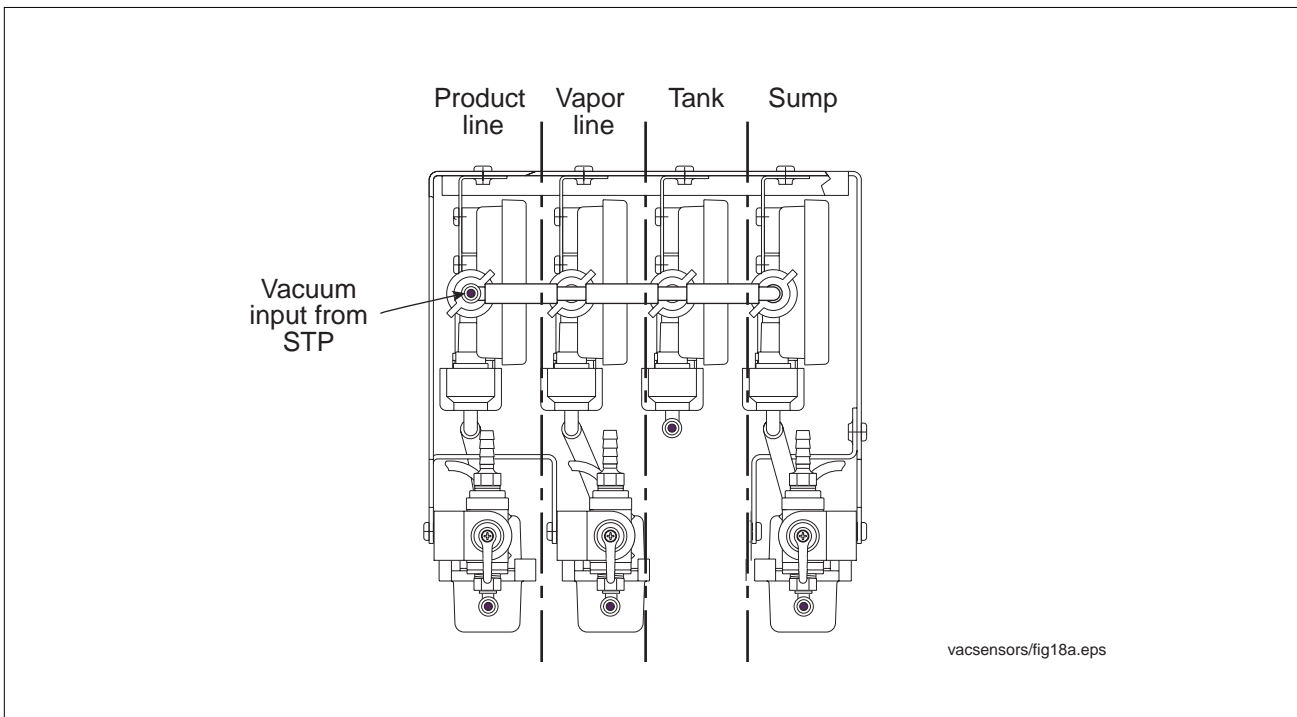

Figure 8. Identifying Vac Sensor/Vac Float pairs

Installing Vac Sensor Housing onto Support Bracket

Route all of the cables through the opening in the mounting bracket and attach the Vac Sensor housing to the bracket by pushing the four hooks on the rear of the housing into the four slots in the bracket (see Figure 9)

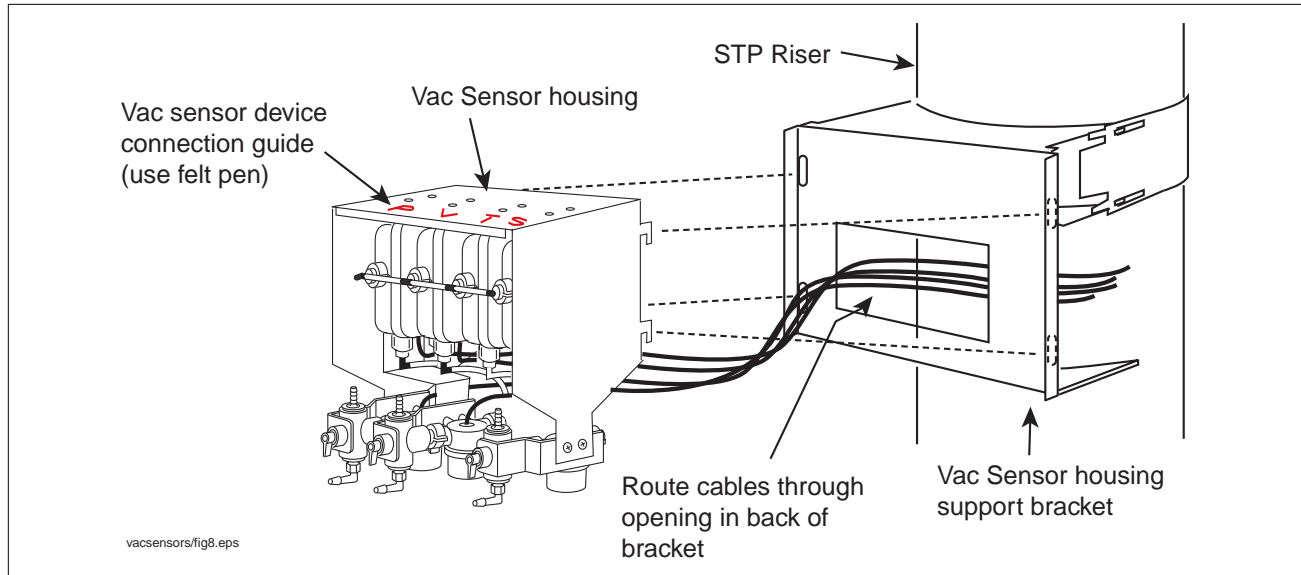

Figure 9. Attaching Vac Sensor housing to support bracket

Vacuum Connections within Sump

Vacuum Connections to a Double-Wall Product Line

1. Get a 1/4" NPT/ barbed adapter and spring clamp from the Vac Sensor install kit.
2. Apply an adequate amount of fresh, UL classified for petroleum, non-setting thread sealant (herein after referred to as sealant) to the threads of the 1/4" NPT barbed fitting and screw it into the 1/4" NPT port in the vacuum termination fitting of the product line (Figure 10).

NOTE: In some installations, the double-walled piping is equipped with one or more Schraeder valves. You can connect the vacuum tubing directly to the Schraeder valve using the Schraeder fitting (P/N 576008-672).

NOTE: any unused Schraeder fittings must be capped to avoid leaks.



3. Get the 1/4" ID tubing from the install kit and measure a piece that will reach the barbed fitting on the bottom of the plastic valve (see Figure 4) that is connected to the Vac Sensor/Vac Float pair you labeled 'P'. Plan enough tubing so that it isn't stretched between fittings or have any sharp bends/kinks in it. Cut and install this tubing and secure tubing ends with spring clamps.

Vacuum Connections to a Double-Wall Vapor Return Line

Repeat steps 1 - 2 of the Product Line connection instructions for the vapor return line connection, except:

- Install the 1/4" NPT barbed fitting in the vacuum termination port of the vapor return line (see Figure 10),
- Connect one end of the tubing to the vapor return line barbed adapter and the other end to the barbed fitting on the bottom of the plastic valve that is connected to the Vac Sensor/Vac Float pair you labeled 'V'. Plan enough

tubing so that it isn't stretched between fittings or have any sharp bends/kinks in it. Cut and install this tubing and secure tubing ends with spring clamps.

Vacuum Connections to a Double-Wall Sump

Repeat steps 1 - 2 of the Product Line connection instructions for the sump interstice connection, except:

- Install the 1/4" NPT barbed fitting in the interstitial space access port provided in the sump's wall (if multiple ports are provided, select the lowest one).
- Connect one end of the tubing to the sump interstice barbed fitting and the other end to the barbed fitting on the bottom of the plastic valve that is connected to the Vac Sensor/Vac Float pair you labeled 'S'. Plan enough tubing so that it isn't stretched between fittings or have any sharp bends/kinks in it. Cut and install this tubing and secure tubing ends with spring clamps.

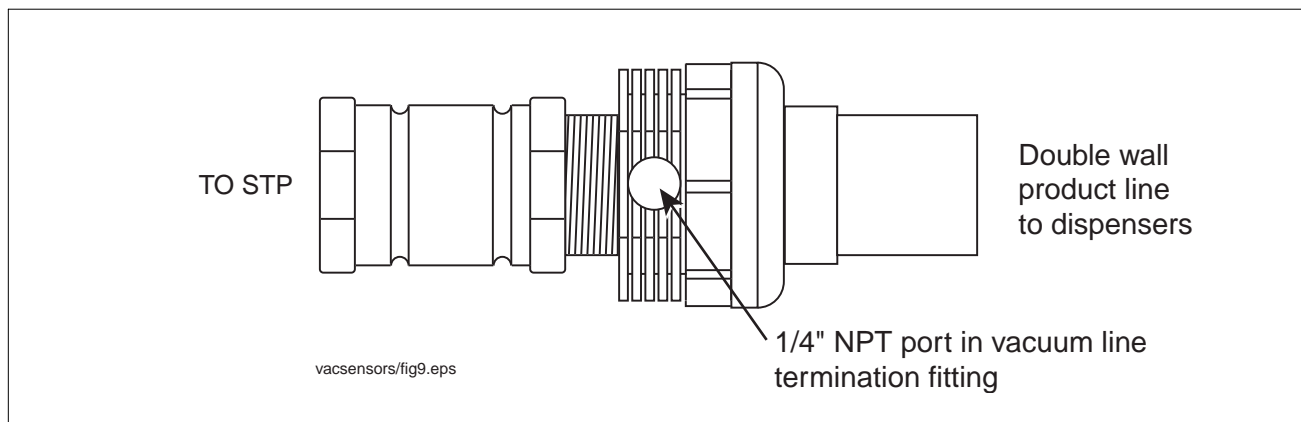

Figure 10. Example vacuum termination fitting - double-wall pipe

Vacuum Connections to a Double-Wall Steel Tank

1. Get the tank's interstitial riser cap, interstitial sensor, cord grip components, 3-way ball valve, 1/4" NPT close nipple, 1/4" NPT/barbed adapter fitting, and spring clamps from the kit.
2. Assemble the cord grip components and apply sealant to its threads. Screw it into the 1/2" NPT hole in the cap.
3. Slowly lower the steel tank interstitial sensor into the tank riser until it rests on the bottom of the riser. Push the end of the sensor's cable through the loosened cord grip in the cap - being careful not to lift the sensor off bottom. Apply sealant to the threads of the riser pipe and screw on the cap until tight. Tighten the cable cord grip.
4. Apply sealant onto the threads of one end of the nipple and screw it into the 1/4" NPT port in the cap. Apply sealant to the other end of the nipple and screw on the 3-way ball valve. Apply sealant to the threaded end of the barbed adapter and screw it into the side port of the 3-way ball valve. (see Figure 11).
5. Measure a length of 1/4" ID tubing to connect the VAC TEST port on the Vac Sensor (labeled 'T') to the tank's interstitial 3-way ball valve. Plan enough tubing to avoid sharp bends in it or stretching it. Cut and install this tubing and secure tubing ends with spring clamps.
6. The Vac Sensor labeled 'T', and which is connected to the 3-way ball valve in the tank interstice riser cap, must be wired together with the tank interstice liquid sensor in the junction box. Locate the ends of the Vac Sensor cable labeled 'T' and the tank interstitial liquid sensor cable, tape them together, and tag them 'Tank Vac Sensor'.

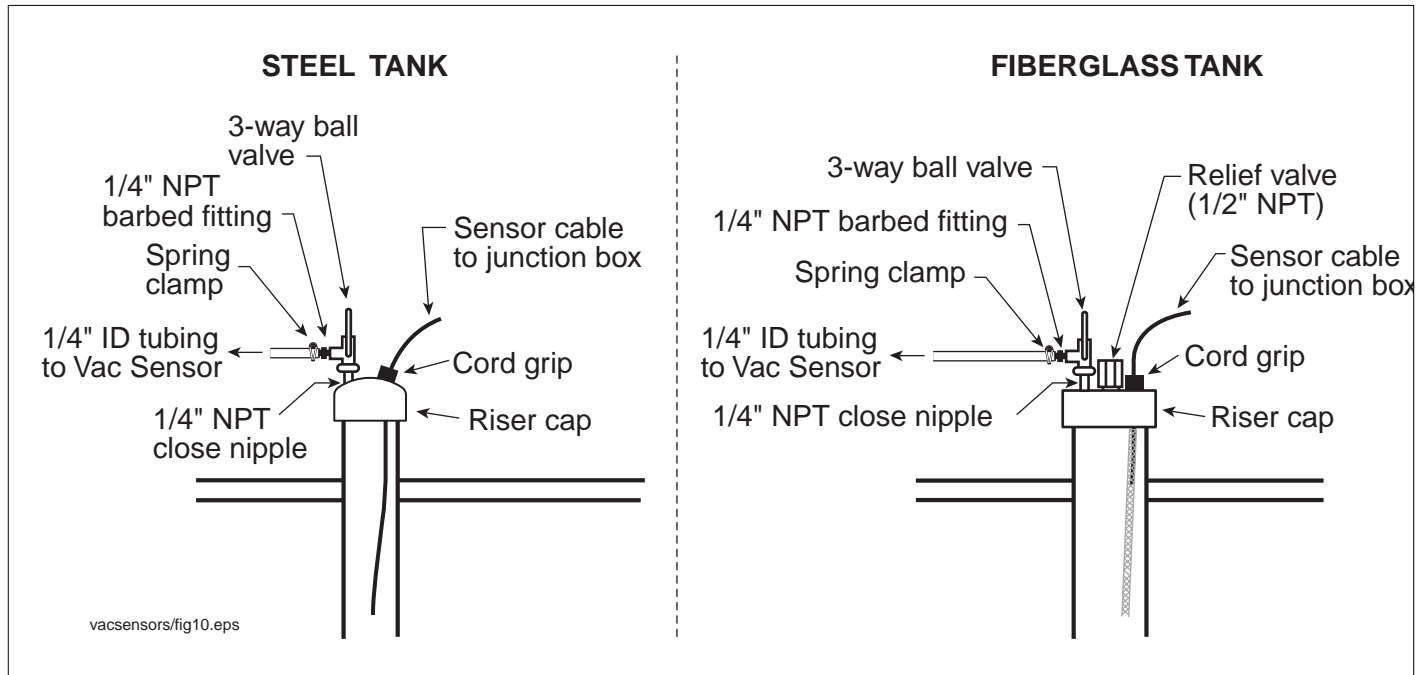

Figure 11. Example tank interstitial sensor riser cap connections - steel and fiberglass tanks

Vacuum Connections to a Double-Wall Fiberglass Tank

1. Get the tank's interstitial riser cap, interstitial sensor, cord grip components, 3-way ball valve, 1/4" NPT close nipple, 1/4" NPT/barbed adapter fitting, spring clamps, and relief valve from the kit.
2. Assemble the cord grip components and apply sealant onto its threads. Screw it into one of the 1/2" NPT holes in the cap.
3. Install the fiberglass tank interstitial sensor into the tank riser following the instructions accompanying the sensor (manual P/N 576013-617). Once installed, push the end of the sensor's cable through the loosened cord grip in the cap - being careful not to alter the sensor's position. Apply an adequate amount of sealant to the threads of the riser pipe and screw on the cap until tight. Tighten the cable cord grip.
4. Apply sealant onto the threads of one end of the nipple and screw it into the 1/4" NPT port in the cap. Apply sealant to the other end of the nipple and screw on the 3-way ball valve. Apply sealant to the threaded end of the barbed adapter and screw it into the side port of the 3-way ball valve. (see Figure 11).
5. Apply sealant onto the threads of the relief valve and screw it into the other 1/2" NPT hole in the cap.



IMPORTANT: You must install the relief valve in the fiberglass tank riser cap or damage to the tank may occur!

6. Measure a length of 1/4" ID tubing to connect the VAC TEST port (ref. Figure 12) on the Vac Sensor labeled 'T' to the tank's interstitial 3-way ball valve. Plan enough tubing to avoid sharp bends in it or stretching it. Cut and install this tubing and secure tubing ends with spring clamps.
7. The Vac Sensor labeled 'T', and which is connected to the 3-way ball valve in the tank interstice riser cap, must be wired together with the tank interstice liquid sensor in the junction box. Locate the ends of the Vac Sensor cable labeled 'T' and the tank interstitial liquid sensor cable, tape them together, and tag them 'Tank Vac Sensor'.

Vacuum Connections to Siphon Port of the Pump

1. Get the 1/4" NPT barbed fitting from the mounting kit. Apply sealant to the threads of the fitting and screw it into the STP siphon port (see Figure 12).

NOTE: It is recommended that you replace the Siphon Jet assembly on FE Petro pumps used with the Vac Sensor.

2. Ensure that the STP's Siphon Port is equipped with a Siphon Check Valve.

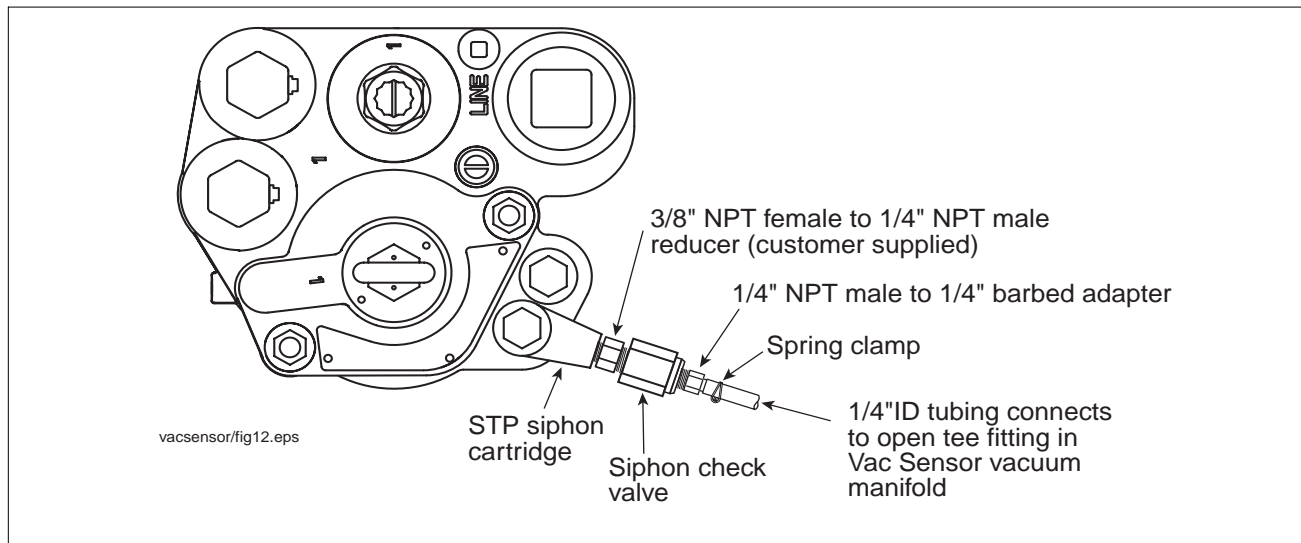

Figure 12. Attaching 1/4" tubing to STP siphon cartridge

3. Measure a length of 1/4" ID tubing to connect 1/4" ID barbed tubing fitting in the siphon cartridge port and the vacuum input open tee of the Vac Sensor (see Figure 13). Plan enough tubing to avoid sharp bends in it or stretching it. Cut and install this tubing and secure tubing ends with spring clamps.

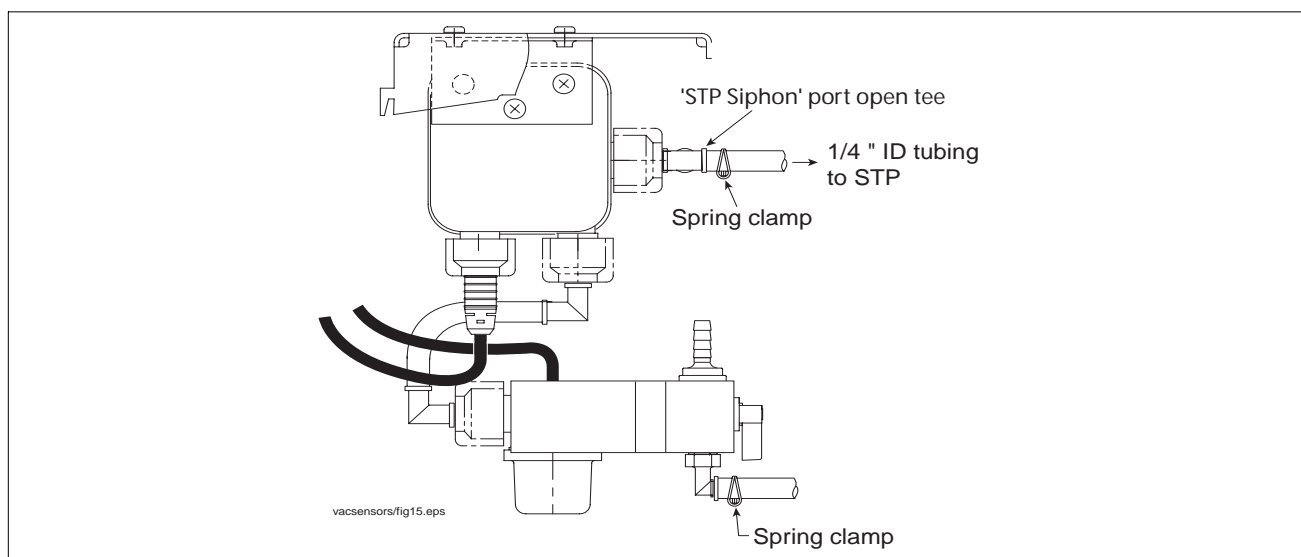

Figure 13. Connecting vacuum tubing from pump siphon port to Vac Sensor

Field Wiring Vac System Connections

1. Tie wrap the loose cable pairs into a bundle going from the Vac Sensor housing to the sump junction box(es).
2. Get necessary cord grip bushings from the kits - one for each Vac Sensor, Vac Float, and the Tank interstitial sensor cable that will enter the junction box(es) in the sump. Loosen the cord grips and screw each one into a junction box port.
3. Push the first Vac Sensor/Vac Float cable pair into adjacent cord grips (keep the pairs together as the two cables will typically be wired to one cable going to the TLS Console). Make sure all of the cables to the console are tagged (e.g., Tank 1 product line, Tank 1 vapor line) to facilitate TLS setup.
4. Strip back the leads of one of the cables from the TLS Console 3/8". Strip back the leads of the Vac Sensor/Vac Float pairs 3/8". Using wire nuts from the kits attach the wires as per the diagram in Figure 14. NOTE: the Vac Sensor cable has three wires and the Vac Float cable has two wires.
5. Seal wire nuts with epoxy sealant following the instructions in Figure 15.
6. Connect the remaining Vac Sensor/Vac Float pairs and the Vac Sensor/Tank Float pair as discussed above, sealing each set of wires in epoxy sealant packs.

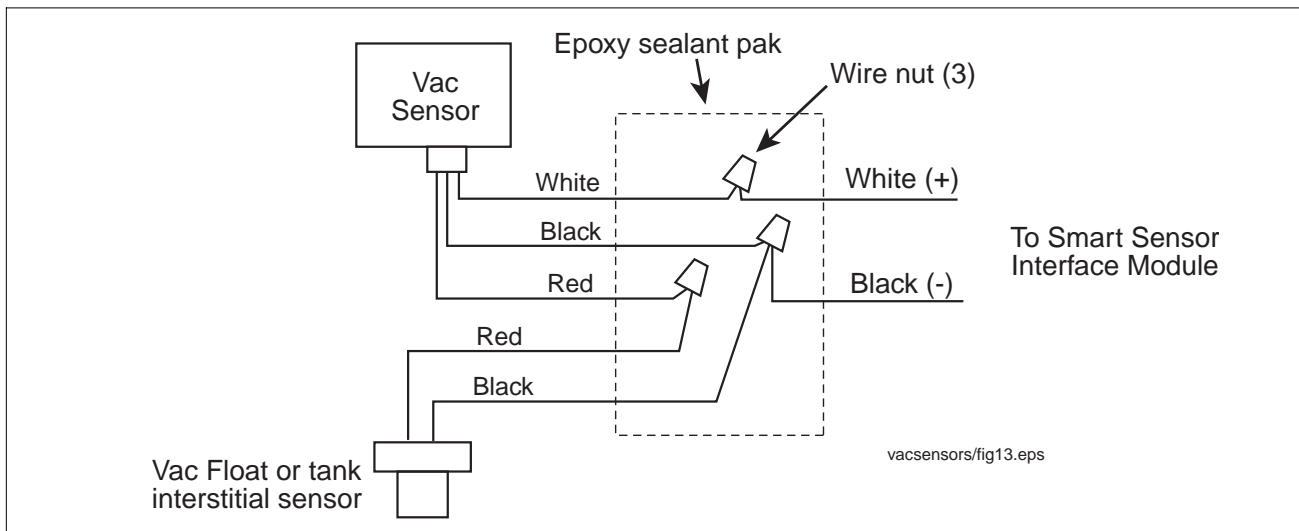

Figure 14. Field wiring connections

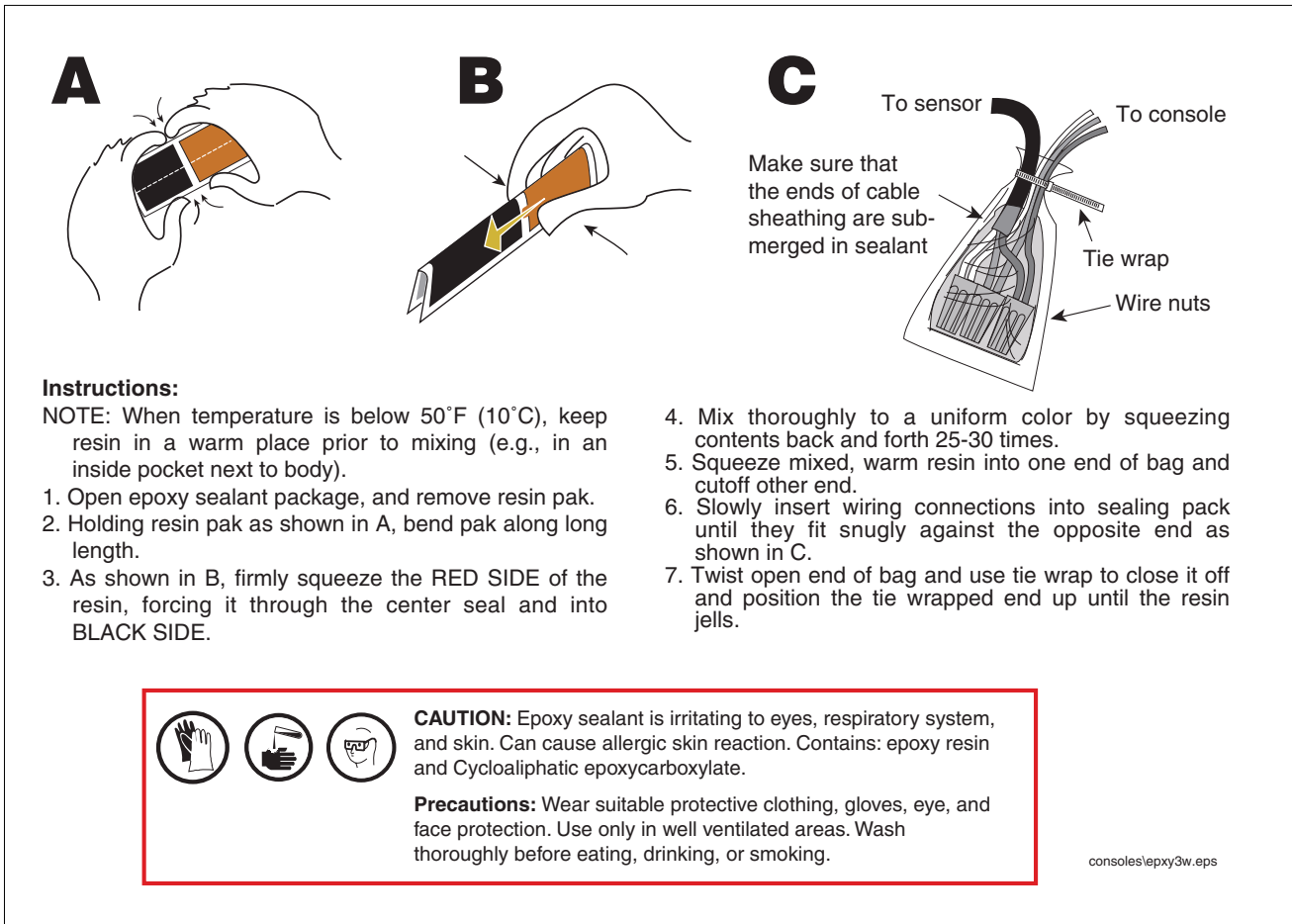

Figure 15. Epoxy sealing wiring connections

Connecting Vac Sensor Field Wiring to TLS Console

1. Connect each Vac Sensor/Vac Float pair and the Vac Sensor/ Tank Interstitial Float pair cables to either a Smart Sensor/Press module or a Smart Sensor Interface module as shown in Figure 16. Note: at least one Smart Sensor/Press module must be installed in the console for proper Vac Sensor operation.
2. System programming of the Vacuum Sensors is performed following instructions in the TLS-3XX Setup Manual.

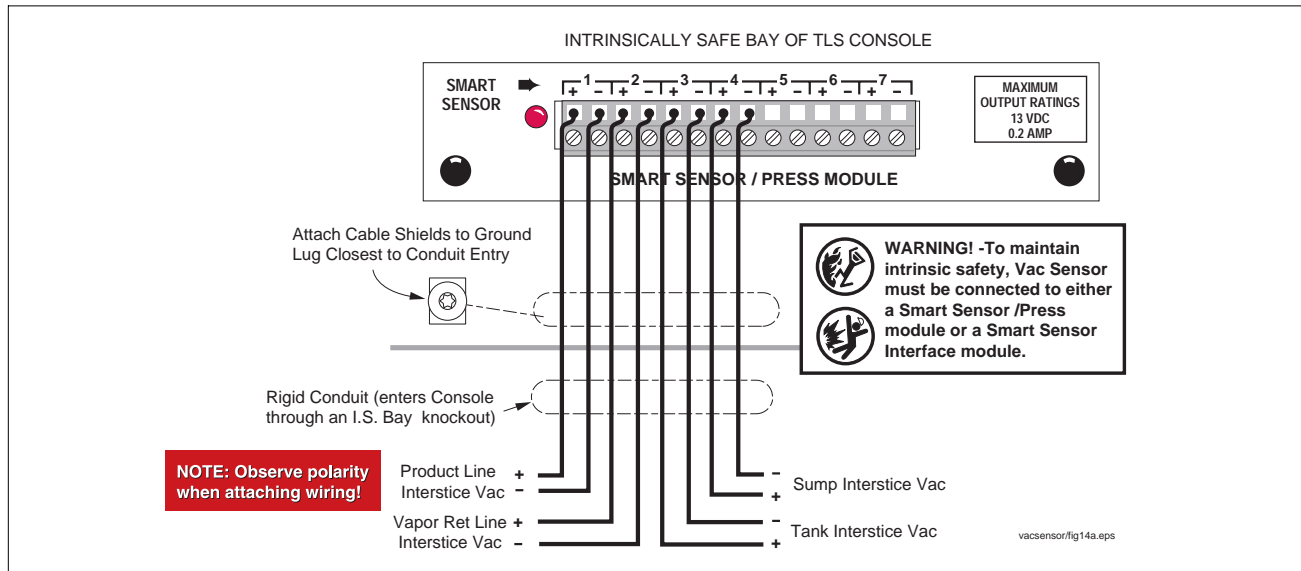

Figure 16. Attaching Vac Sensors to Smart Sensor / Press Module

Connecting Pump Control Field Wiring to TLS Console

For Sites with PLLD or WPLLD Leak Detection

Pump control for Vac Sensors is shared with PLLD or WPLLD line leak detection. Connecting PLLD/WPLLD leak detection as per the instructions provided with that equipment is all that is required.

For Sites without PLLD or WPLLD Leak Detection

A Pump Sense module and a 4-Relay module are required in the TLS Console for Vac Sensor pump control.

Field Wiring:

- For module connections with Red Jacket pumps see Figure 17. For module connections with non-Red Jacket pumps see Figure 18.

Console Setup:

- Pump Sense setup - assign each tank to Pump Sense device
- Output Relay setup - select 'Pump Control Output'

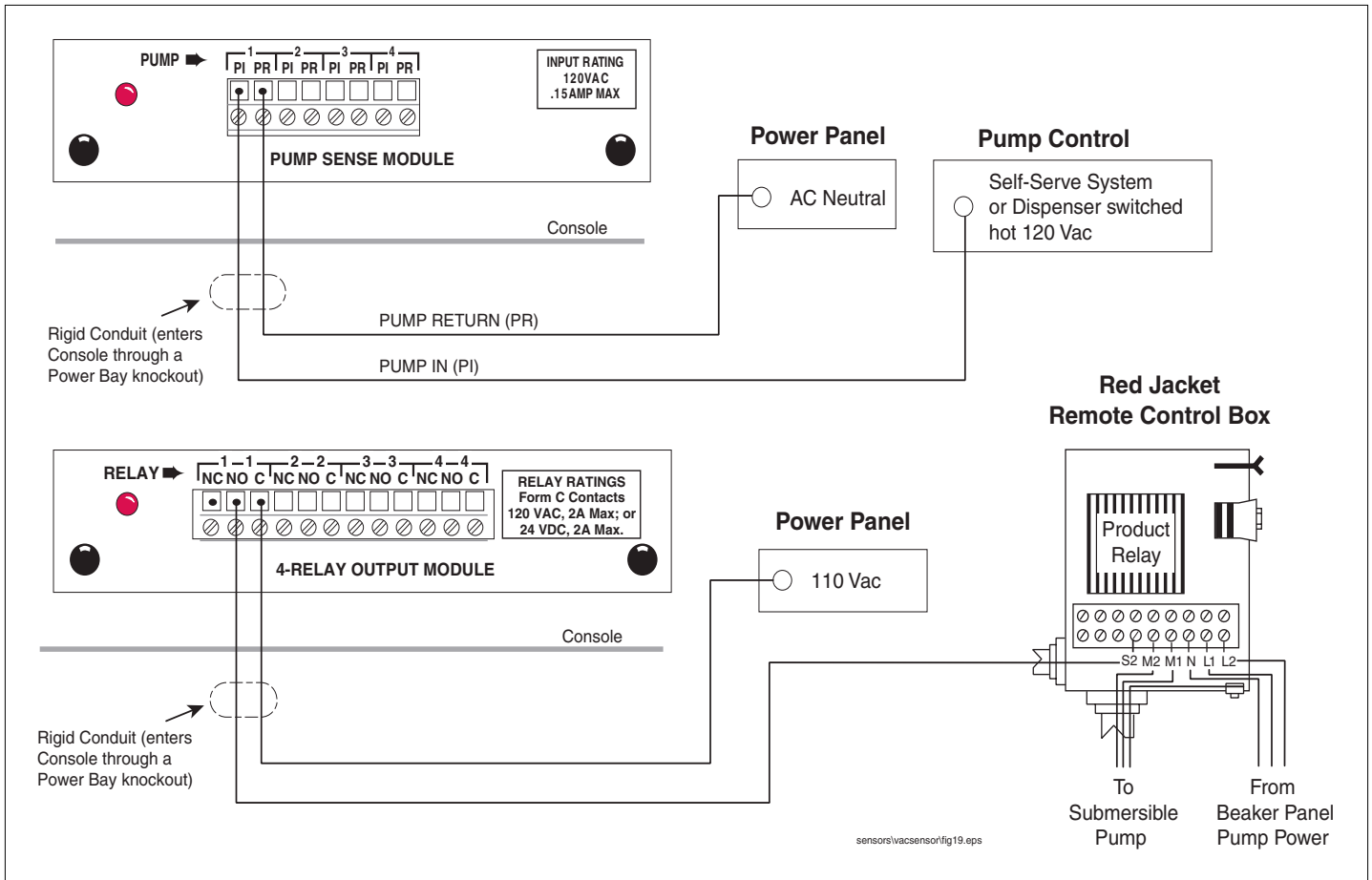

Figure 17. Connecting Pump Sense & 4-Relay Modules - Red Jacket Pumps

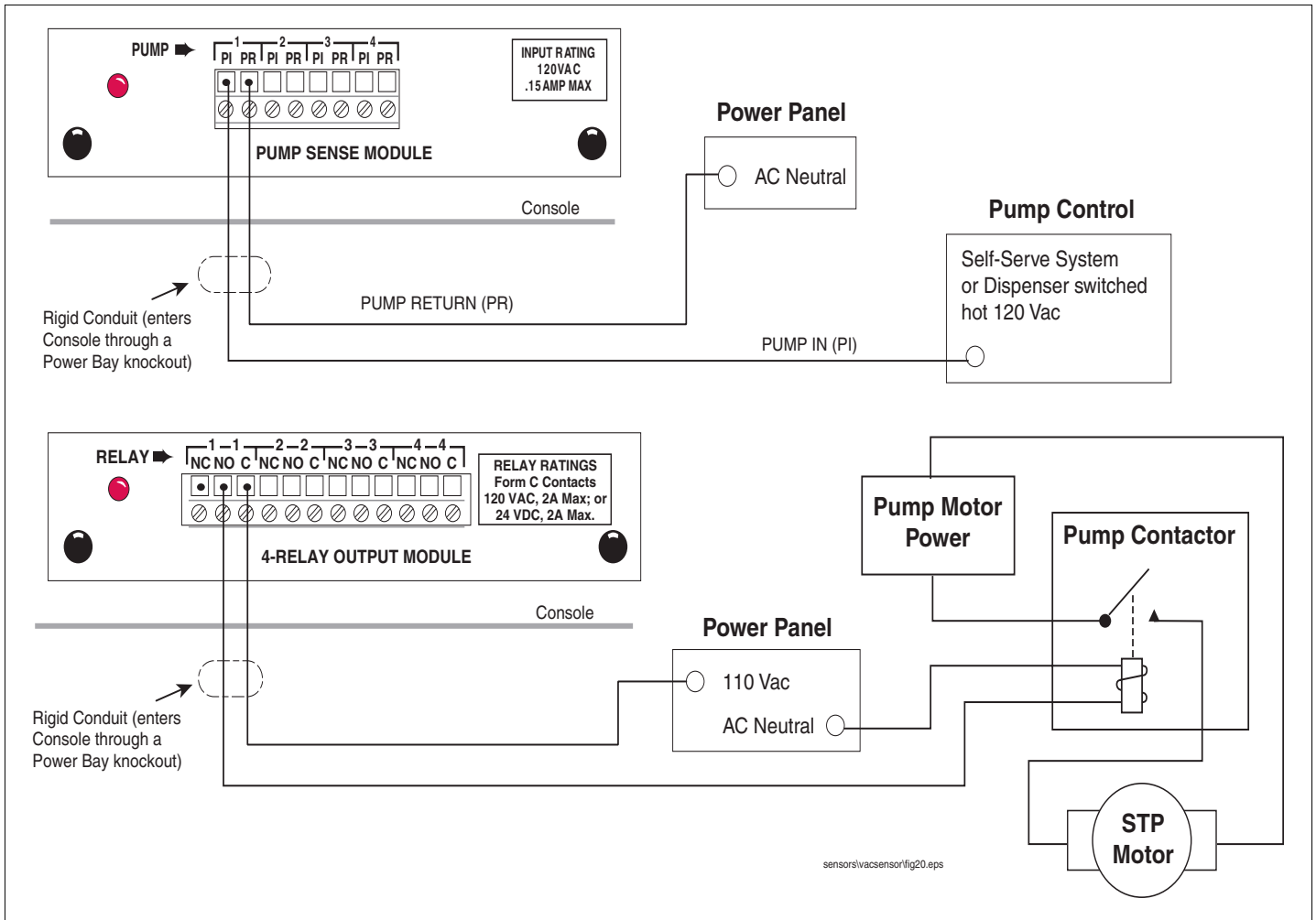

Figure 18. Connecting Pump Sense & 4-Relay Modules - Non-Red Jacket Pumps

Disable Extended Run Feature in the Pump Controller

! IMPORTANT! Certain pump controllers may be programmed to turn off the pump after an extended run period and post an ER (Extended Run) error in the controller. Because the Vac Sensors may require the pumps to run for several hours and possibly triggering this error, you must disable this ER feature in the pump controller. Refer to the Pump Controller's documentation for instructions on how to disable the Extended Run feature.

Vac System Testing

This section describes a sequence of procedures and tests necessary to complete the Vac Sensor installation:

1. ATM Pressure Sensor setup
2. Vac Sensor setup
3. Vacuum integrity test prior to filling tank*
4. Manual test*
5. Operability test

*NOTE: Only one of these two tests is required to complete the installation.

ATM Pressure Sensor Setup

The ATM Pressure Sensor is factory installed in the SmartSensor / Press module and preassigned to channel 8. At least one SmartSensor / Press module, which contains the ATM Pressure Sensor, must be installed in the console. You must configure at least one ATM Pressure Sensor for use by the Vac Sensors or a Setup Data Warning will occur. NOTE: if more than one SmartSensor / Press module is installed, only one ATM Pressure Sensor needs to be configured.

Look in console and note the slot position of the SmartSensor / Press module. Enter the Setup Mode and press the FUNCTION key until you see the message:

```
SMARTSENSOR SETUP  
PRESS <STEP> TO CONTINUE
```

Press STEP until you see the message:

```
SS CONFIG - MODULE n  
SLOT x - X X X X X X X X
```

Where *x* is the slot number containing the SmartSensor / Press module. Press the → key to move the cursor to the last (8th) X. Press CHANGE and the message below should appear:

```
SLOT x - X X X X X X X 8  
PRESS <STEP> TO CONTINUE
```

Press STEP:

```
ENTER SMARTSENSOR LABEL  
s 8:
```

NOTE: In the example above, the ATM P sensor position is 8 but it could be 16, 32, or 40 depending on the SmartSensor's module number.

Press CHANGE and enter a label:

```
ENTER SMARTSENSOR LABEL  
s 8: (ATMP Sensor Label)
```

Press ENTER to accept your label:

**s 8: (ATMP Sensor Label)
PRESS <STEP> TO CONTINUE**

Press STEP:

**s 8: SELECT SS CATEGORY
UNKNOWN**

Press CHANGE until you see the message:

**s 8: SELECT SS CATEGORY
ATM P SENSOR**

Press ENTER to accept the category. Press STEP, then BACKUP to return to the configuration display for Smart Sensor module 1:

**SS CONFIG - MODULE 1
SLOT x - X X X X X X X**

This completes the ATM Pressure Sensor configuration.

Vac Sensor Setup

Identifying Vac Sensor Zones

Before configuring the Vac Sensors, enter the Monitored Zone, SmartSensor module number, and channel number for each Vac Sensor attached to the console in the worksheet in Table 1 below. NOTE: The Vac Sensor Zone Worksheet and the Secondary Containment Volumes By Manufacturer index are both included in the installation kit (P/N 577013-849). Use the Containment Volume index to calculate a zone's interstice volume in gallons. For example, if Tank 1's double wall product piping uses 100 feet of Ameron Dualoy 3000/L piping, you would multiply 0.2186 (from the Secondary Containment Volume index) x 100 feet = 21.86 gallons. For the Tank 1 product piping zone you would enter 21.9 (round to nearest tenth of a gallon) as the calculated zone volume. If the Tank 1 sump is a Containment Solutions 42" Double wall tank sump, you would multiply 0.8216 (from the Secondary Containment Volume index) x 3.5 feet = 2.88 gallons as the calculated zone volume

Table 1. Vac Sensor Zone Worksheet

Vac Sensor Monitored Zone	SS Module Number	SS Module Channel Number	Calculated Zone Volume (Gallons)
	1	1	
	1	2	
	1	3	
	1	4	
	1	5	
	1	6	
	1	7	

Table 1. Vac Sensor Zone Worksheet

Vac Sensor Monitored Zone	SS Module Number	SS Module Channel Number	Calculated Zone Volume (Gallons)
	1	8	
	2	9	
	2	10	
	2	11	
	2	12	
	2	13	
	2	14	
	2	15	
	2	16	
	3	17	
	3	18	
	3	19	
	3	20	
	3	21	
	3	22	
	3	23	
	3	24	
	4	25	
	4	26	
	4	27	
	4	28	
	4	29	
	4	30	
	4	31	
	4	32	
	5	33	
	5	34	
	5	35	
	5	36	
	5	37	
	5	38	
	5	39	
	5	40	

Performing Vac Sensor Setup

After filling in the Vac Sensor Zone Worksheet, enter the Setup Mode and press the FUNCTION key until you see the message:

```
SMARTSENSOR SETUP
PRESS <STEP> TO CONTINUE
```

Press STEP until you see the message:

```
SS CONFIG - MODULE 1
SLOT x - X X X X X X X
```

Following the completed Vac Sensor Zone Worksheet, configure each Vac Sensor channel for all SmartSensor modules. NOTE: Once the console communicates with a Vac Sensor (approximately 2 minutes after configuration), it automatically selects the Vac Sensor SS Category for that sensor.

When all Vac Sensors have been configured, if necessary, press Tank/Sensor until you see the message:

```
s 1: VAC SENSOR SETUP
PRESS <ENTER>
```

Press ENTER:

```
s 1: SELECT PUMP #
NONE
```

You must select the pump that will provide the source of vacuum for this Vac Sensor or a Setup Data Warning will be posted for this Vac Sensor. If necessary, press CHANGE until the correct pump's control device displays [QX (PLLD), WX (WPLLD), or RX (Output Relay)]. NOTE: an Output Relay must be set to Pump Control Output to be assigned as a pump. If the selected pump output relay is not assigned to a pump sense device, a Setup Data Warning for this Vac Sensor will be posted.

Press ENTER to confirm your entry.

Press STEP to continue:

```
s 1: (Vacuum Label)
VOLUME:      501
```

Referring to your previously completed volume worksheet, enter the volume in gallons of the interstitial space being monitored by this Vac Sensor. The permitted range is 0.1 to 500 gallons. Default is 501. A Setup Data Warning alarm will activate if a volume between 0.1 and 500 is not entered.

Press CHANGE and enter the interstitial space volume. Press ENTER to confirm your entry.

Press STEP to continue:

```
s 1: (Vacuum Label)
RELIEF VALVE: NO
```

For all Vac Sensors except the one monitoring a fiberglass tank's interstitial space, a relief valve is usually not needed. For Vac Sensors not requiring a relief valve press STEP to accept the default NO. Press Tank/Sensor to setup another Vac Sensor.

For the Vac Sensor that monitors a fiberglass tank's interstitial space, a relief valve is required to prevent excess vacuum from damaging the tank. Press CHANGE and select YES. Press ENTER to confirm your entry.

Press STEP to continue.:

s 1: (Vacuum Label)
RELIEF VALVE PRESSURE: -9.0

Enter the pressure at which the installed Relief Valve is rated to open (the vent pressure is stamped on the body of the V-R Relief Valve). The permitted range is -5 to -9 psi. Default vent pressure is -9 psi. Press ENTER to confirm your entry. Press Tank/Sensor to setup another Vac Sensor.

Vacuum Integrity Test Prior to Filling Tank (Optional)

Skip to 'Running a Manual Test' if this optional test is not going to be performed.

If an external vacuum source is not used to produce a vacuum in the monitored zones prior to startup, you must perform a 'Manual Test' on each sensor to clear the 'No Vac' alarm.

A procedure to test the integrity of the interstitial spaces monitored by the Veeder-Root Vacuum Sensors is discussed in this section. An external vacuum source and necessary fittings must be supplied by the customer.

Before beginning this procedure all vacuum sensor components in the sump must be installed as described in this manual and be connected to a SmartSensor module in the TLS Console.



1. Shut off, tag, and lock out power to the pump.
2. At the TLS Console, configure each of the monitored Vac Sensors in the sump (ref. TLS-3XX Setup Manual). Go to the SmartSensor Diag and place each of the monitored Vac Sensors in EVAC HOLD (ref. TLS-3XX Troubleshooting Manual).
3. At the 3-way ball valve connected to the tank's interstitial riser cap, connect the external vacuum source to the valve's top barbed fitting. Rotate the valve handle to its up position and pull a vacuum down to -8 psi, or if a relief valve is present, down to 1 psi above the relief valve's opening pressure (e.g., if valve opens at -7 psi, pull the vacuum down to -6 psi). When the desired vacuum is attained, rotate the valve handle to its down position. Remove the external source from the valve's upper barbed fitting.
4. If necessary, repeat this procedure for the product line's interstitial space, the vapor line's interstitial space and the double-wall sump's interstitial space.
5. With all of the monitored interstitial spaces under vacuum, at the TLS Console, stop the EVAC HOLD for each Vac Sensor. After a minimum wait of 12 minutes, monitor the Leak Rate and Time to No Vac display for each Vac Sensor. Record the displayed values for each of the sump's vac sensor in the chart in Appendix B.

As a general guideline, the Time to No Vac should ideally be 100 hours, and should not be less than 24 hours (a time less than 2 hours will produce an alarm). Also, a Leak Rate greater than 22.4 gph will generate a Vacuum Warning. Both of these diagnostics are indicators of whether the system has a significant vacuum leak. Note that on systems with small volumes, a very small leak rate, well below the 22.4 gph limit, may still cause a Time to No Vac alarm.

If either diagnostic exceeds the guideline, the source of the leak should be corrected before the system is started up. Once the leak(s) is corrected, repeat steps 2-6.

6. When the monitored interstitial spaces under vacuum are within normal operating limits as described in Step 6, fill the tank.
7. Once the tank is full, restore power to the pump.

Running a Manual Test

Perform the Manual Test for Each Vac Sensor

You enter the DIAG MODE of the TLS Console by pressing the MODE key until its display appears. Press the FUNCTION key to select diagnostic functions and the STEP key to view each of the Function's displays. Where you can enter changes to displayed data, you do so with the same front keys used enter to system programming selections (i.e., ENTER, CHANGE, etc.).

Figure 19 displays the Vac Sensor Manual Test procedure steps and Figure 20 displays the Vac Sensor Evac Hold procedure steps.

Vacuum Sensor Operability Test - Required for Each Sensor Prior to Startup

1. Vacuum leak test: Turn the 3-way ball valve handle (connected to the interstice being monitored) from its down 'operating' position all the way up to its 'test' position. This should vent the vacuum sensor to atmosphere while maintaining vacuum in the interstice.
2. Wait at least 1 minute at the console for the system to produce a 'No Vac' alarm. Press the console's Alarm/Test key to silence the beeper and acknowledge the alarm.
3. Turn the 3-way ball valve handle all the way down to its 'operating' position.
4. At the console enter the DIAG MODE and initiate a manual test that will clear the 'No Vac' alarm (Refer to Figure 19 for Manual Test instructions).
5. Vac Float Liquid Sensor (in sump) test: This test is performed using water, gasoline, or other appropriate test liquid for systems with the float housing in the sump. Unscrew the lower float bowl (about a 1/4 turn) from the Vac Float body and fill the bowl with the test liquid. Screw the filled bowl back onto the Vac Float body and a Liquid Alarm will be generated. At the console press the Alarm/Test key to silence the beeper and acknowledge the alarm. Again unscrew the bowl to clear the alarm. Empty the bowl, wipe it clean, then screw it onto the Vac Float body.
6. For double-walled tanks, the interstitial sensor must be removed from the tank to perform a functional test. Refer to the Operability Testing Guide (P/N 577013-814) and follow 'Testing Procedure C' (interstitial sensor for steel tanks) or 'Testing Procedure E' (interstitial sensor for fiberglass tanks) as applicable.
7. Print the test history and console status for your records. This completes the test procedure. Report any performance concerns to Veeder-Root while on site.

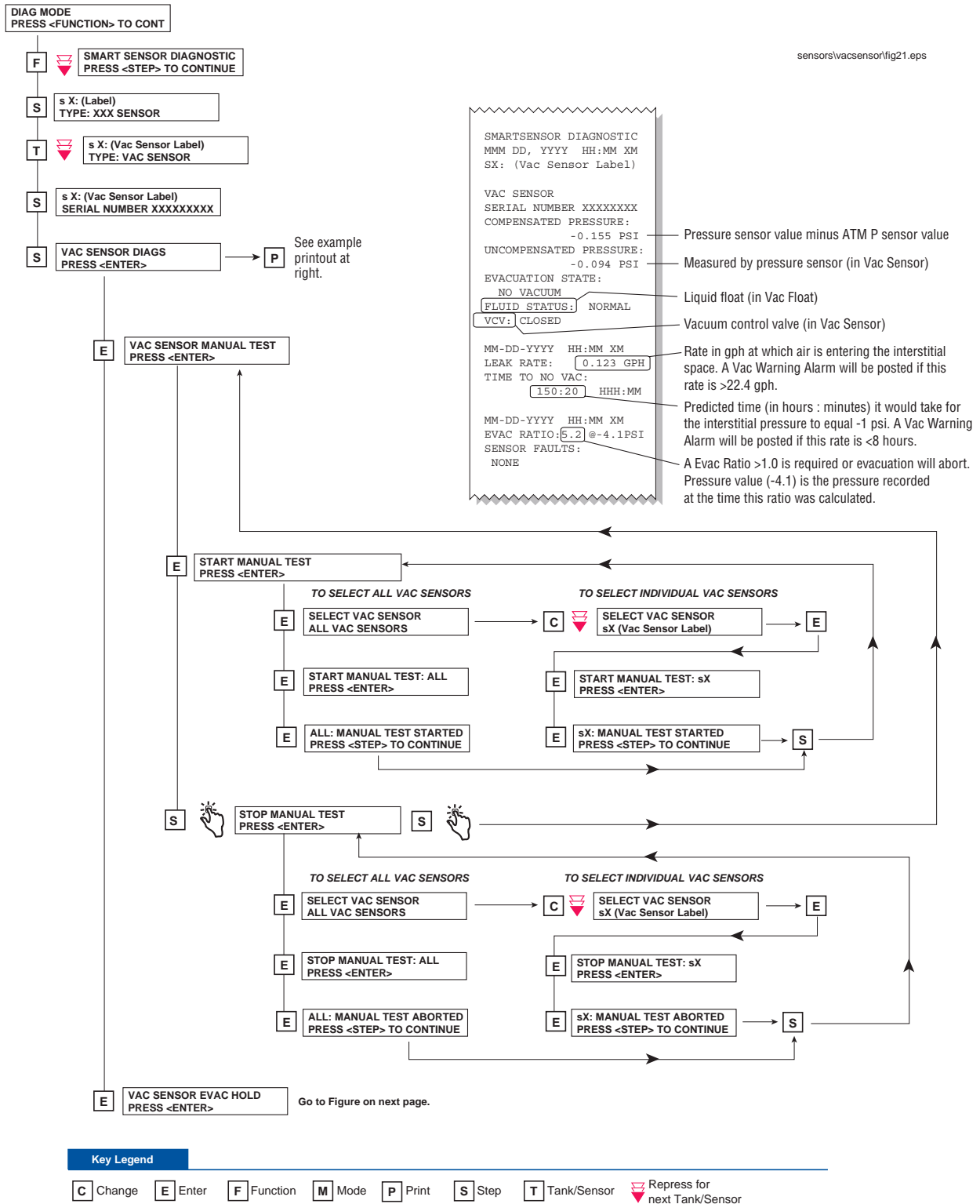

Figure 19. TLS Console Vac Sensor Manual Test

Continued from previous page.

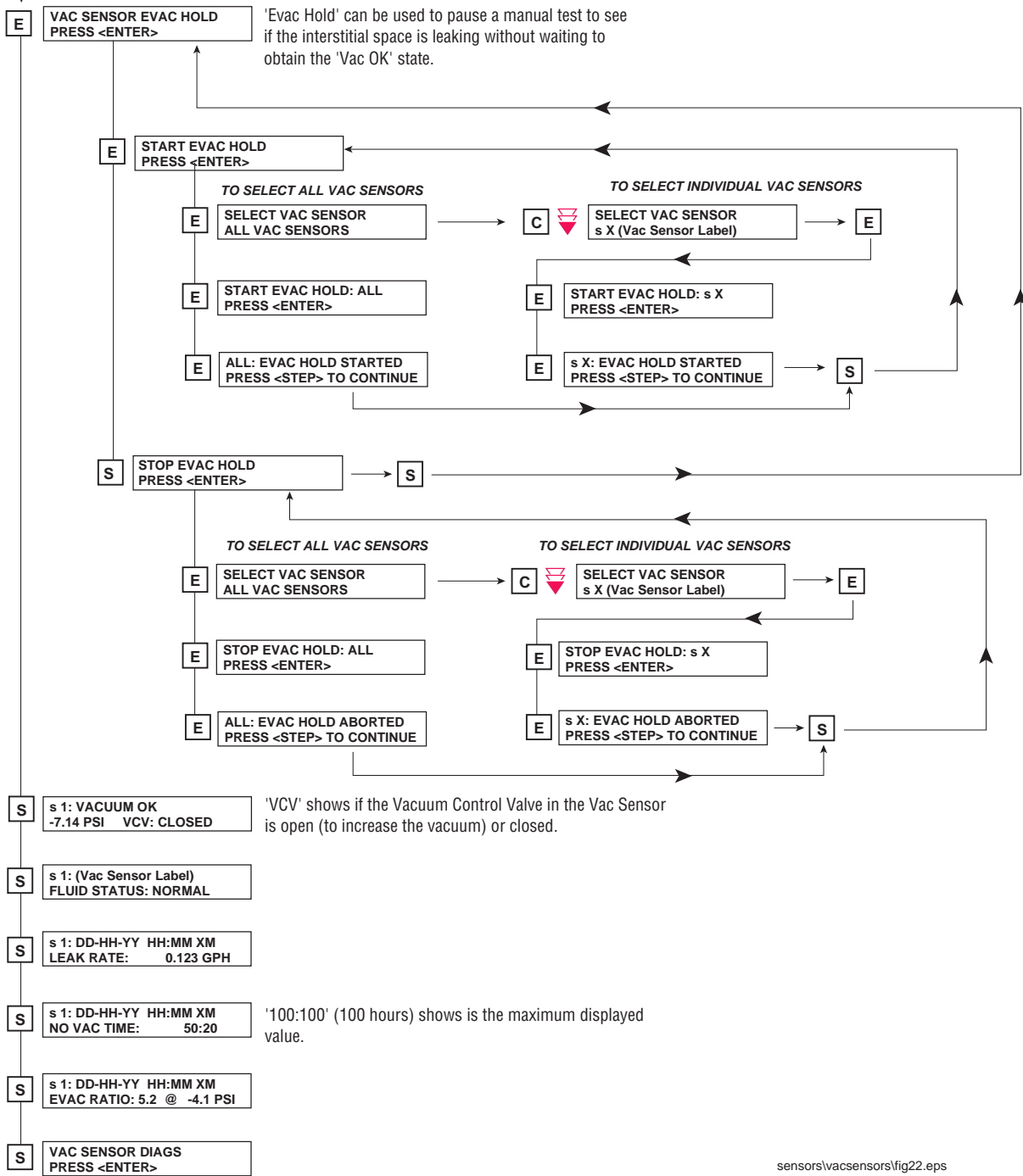

Figure 20. TLS Console Vac Sensor Evac Hold Procedure

Appendix A: Vac Sensor Test Values Record

The leak rate for each interstice will affect the 'Time to No Vac', which is the time it would take for the vacuum to be lost if the STP did not turn on to replenish it. However, the smaller the volume, the greater the impact of a small leak on the 'Time to No Vac'. A general guideline is to eliminate any leaks so that the 'Time to No Vac' reads 100 hours, which is the maximum displayed value.

Use the chart below to record Vac Sensor test values.

TANK	VAC SENSOR	LEAK RATE (gph)	TIME TO NO VAC (hr)
	Product Line		
	Vapor Return Line		
	Tank or Tank Vent		
	Sump		
	Product Line		
	Vapor Return Line		
	Tank or Tank Vent		
	Sump		
	Product Line		
	Vapor Return Line		
	Tank or Tank Vent		
	Sump		
	Product Line		
	Vapor Return Line		
	Tank or Tank Vent		
	Sump		
	Product Line		
	Vapor Return Line		
	Tank or Tank Vent		
	Sump		

