

4" Submersible Petroleum and AG Pump

Installation, Operation & Service Manual

Red Jacket

TABLE OF CONTENTS

Table of Figures & Tables	ii
About This Manual	iii
Abbreviations and Symbols	iv
CHAPTER 1: RED JACKET 4" SUBMERSIBLE PUMP	1
Overview	1
Leak Detector Installation and Manifold Dimensions	2
Recommended Floating Suction Installation	3
Dimensions for Pump Selection	4
Specifications	6
CHAPTER 2: INSTALLATION	9
Installation Safety Notices	9
Attaching the UMP	9
Installing the Pump	10
Conduit Box Wiring	13
Installing Two Pumps for Tandem Operation	16
Adjusting the Functional Element	18
CHAPTER 3: TESTING THE INSTALLATION	20
Testing Piping	20
Testing Tank	20
CHAPTER 4: SERVICE AND REPAIR	21
Technical Support	21
Removing the Pump	21
Replacing the UMP	22
Replacing the Functional Element	23
Replacing the Capacitor in Packer	24
Installing a Replacement Extractable Pump	24
Parts Lists	28
APPENDIX A: 4" STANDARD RED JACKET SAFETY INSTRUCTIONS.....	A-1
APPENDIX B: DECLARATION OF CONFORMITY.....	B-1

TABLE OF FIGURES & TABLES

Table A: Specific Gravity and Maximum Viscosity	1
Figure 1.1 Leak Detector and Manifold Dimension	2
Figure 1.2 Floating Suction Installation	3
Figure 1.3 Floating Suction Adapter.....	3
Figure 1.4 Measuring the Tank.....	4
Table B: Pump Selection	5
Table C: Distance from Eye Bolt to Inlet	6
Table D: Weights and Lengths	7
Table E: Attaching the UMP	9
Figure 2.1 Attaching the UMP	10
Figure 2.2 Aligning the Gasket.....	10
Figure 2.3 Measuring the Tank.....	11
Figure 2.4 Loosen the Fittings	11
Figure 2.5 Adjusting the Pump.....	12
Figure 2.6 Wiring Schematic	13
Figure 2.7 Conduit Box Wiring	13
Figure 2.8 230 VAC Remote Control Box with 110 VAC Coil	14
Figure 2.9 Suggested Wiring Diagram without Control Box	14
Figure 2.10 230 VAC Remote Control Box with 110 VAC Coil and Capacitor.....	15
Figure 2.11 230 VAC Remote Control Box with 230 VAC Coil	15
Figure 2.11a Isotrol to IQ System Wiring - 120 Volt Dispenser Signals	15a
Figure 2.11b Isotrol to IQ System Wiring - 230 Volt Dispenser Signals	15b
Figure 2.12 Tandem Pumps	16
Figure 2.13 Suggested Wiring for Tandem Pumps	16
Figure 2.14 Functional Element	18
Table F: Approximate Operating Pressures	19
Figure 3.1 Closing the Check Valve	20
Figure 3.2 Line Test Port	20
Figure 4.1 Packer.....	21
Figure 4.2 Removing the UMP.....	22
Figure 4.3 Replacing the Gasket	22
Figure 4.4 Packer with Functional Element	23
Figure 4.5 Functional Element	23
Figure 4.6 Loosen the Fittings	25
Figure 4.7 Adjusting the Pump.....	25
Figure 4.8 Wiring Schematic	26

ABOUT THIS MANUAL

This preface describes the organization of this manual, explains symbols and typographical conventions used, and defines vital terminology. This manual is for personnel who install Red Jacket submersible pumps for petroleum. It contains the information required for working in the pit. It also contains a table of figures, a list of abbreviations, the parts list, and an index.

ORGANIZATION

This manual is organized into four chapters:

Chapter 1: Red Jacket Submersible Pump describes the basic components of the system.

Chapter 2: Installation provides safety notices and gives step-by-step instructions for installing and wiring the pump, tandem pumps and control boxes. It also describes how to adjust the Functional Element.

Chapter 3: Testing the installation describes testing the various components of the system after it has been installed.

Chapter 4: Service and Repair describes how to remove a pump and replace the UMP, information on replacing the Functional Element, capacitor, and replacement pump installation instructions.

TYPOGRAPHICAL CONVENTIONS

The various symbols and typographical conventions used in this manual are described here.



Indicates a **tip** or reminder.

TERMINOLOGY

The following defined terms are used throughout this manual to bring attention to the presence of hazards of various risk levels, or to important information concerning use of the product.

DANGER

Indicates the presence of a hazard that will cause severe personal injury, death, or substantial property damage if ignored.

WARNING

Indicates the presence of a hazard that can cause severe personal injury, death, or substantial property damage if ignored.



CAUTION

Indicates the presence of a hazard that will or can cause minor personal injury or property damage if ignored.

NOTICE

Indicates special instructions on installation, operation, or maintenance that are important but not related to personal injury hazards.

ABBREVIATIONS AND SYMBOLS

	Chassis ground (see also GND)
	Earth ground
Ω	Ohm, resistance
μF	Microfarad (10^{-6} farad)
AG	Alcohol-gasoline blends
C	Centigrade
DOM	Domestic
EPA	Environmental Protection Agency
F	Fahrenheit
FL	Fixed Length
FSA	Floating Suction Adapter
ft-lb	Foot-pound
GND	Ground
gph; gpm	Gallons per hour; Gallons per minute
hp	Horsepower
Hz	Hertz
INTL	International
ISO	International Organization for Standardization
kPa	KiloPascals
mm	Millimeter
N•m	Newton-meter
NEC	National Electrical Code
NFPA	National Fire Protection Association
NPT	National Pipe Thread
Petro	Petroleum
PH	Phase
psi; psig	Pounds per square inch; Pounds per square inch gauge
SG	Specific Gravity
SSU	Saybolt Seconds Universal, a measure of viscosity
UL	Underwriters Laboratories Inc.
UMP	Unit motor pump; Pump-motor assembly
VAC	Voltage—alternating current
V	Volt
VDC	Voltage—direct current

CHAPTER 1: RED JACKET 4" SUBMERSIBLE PUMP

OVERVIEW Red Jacket pumps are designed to be compatible with 100% gasoline or diesel. All UMPs having the model numbers including the AG prefix are designed to be compatible with 100% gasoline, methanol, ethanol or diesel and 80% gasoline with 20% TAME, ETBE or MTBE. Single phase pumps are UL listed Class 1, Group D atmosphere.

TABLE A: SPECIFIC GRAVITY AND MAXIMUM VISCOSITY

UMP Model	Maximum Specific Gravity	Maximum Viscosity
AGUMP33R1 UMP33R1	.95	70SSU at 60° F (15° C)
AGUMP75S1 UMP75S1	.95	70SSU at 60° F (15° C)
AGUMP150S1 UMP150S1	.95	70SSU at 60° F (15° C)
AGUMP75S3-3 UMP75S3-3	.95	70SSU at 60° F (15° C)
AGUMP150S3-3 UMP150S3-3	.95	70SSU at 60° F (15° C)
X3AGUMP150S1 X3UMP150S1	.80	70SSU at 60° F (15° C)
X5AGUMP150S1 X5UMP150S1	.80	70SSU at 60° F (15° C)
X4AGUMP150S3 X4UMP150S3	.86	70SSU at 60° F (15° C)
AGUMP75S17-3 UMP75S17-3	.95	70SSU at 60° F (15° C)
AGUMP150S17-3 UMP150S17-3	.95	70SSU at 60° F (15° C)
X4AGUMP150S17 X4UMP150S17	.86	70SSU at 60° F (15° C)

The Quick-Set feature is an adjustable column pipe and electrical conduit that allows the overall length to be adjusted to cover a wide range of overall pump lengths. By loosening a collet on the column pipe, the length of the pump may be varied by extending or compressing the column pipe.

Four Quick-Set sizes are available, covering most pump length requirements, for precise lengths, see the sizing charts within this chapter.

4" Petroleum & AG

LEAK DETECTOR INSTALLATION AND MANIFOLD DIMENSIONS

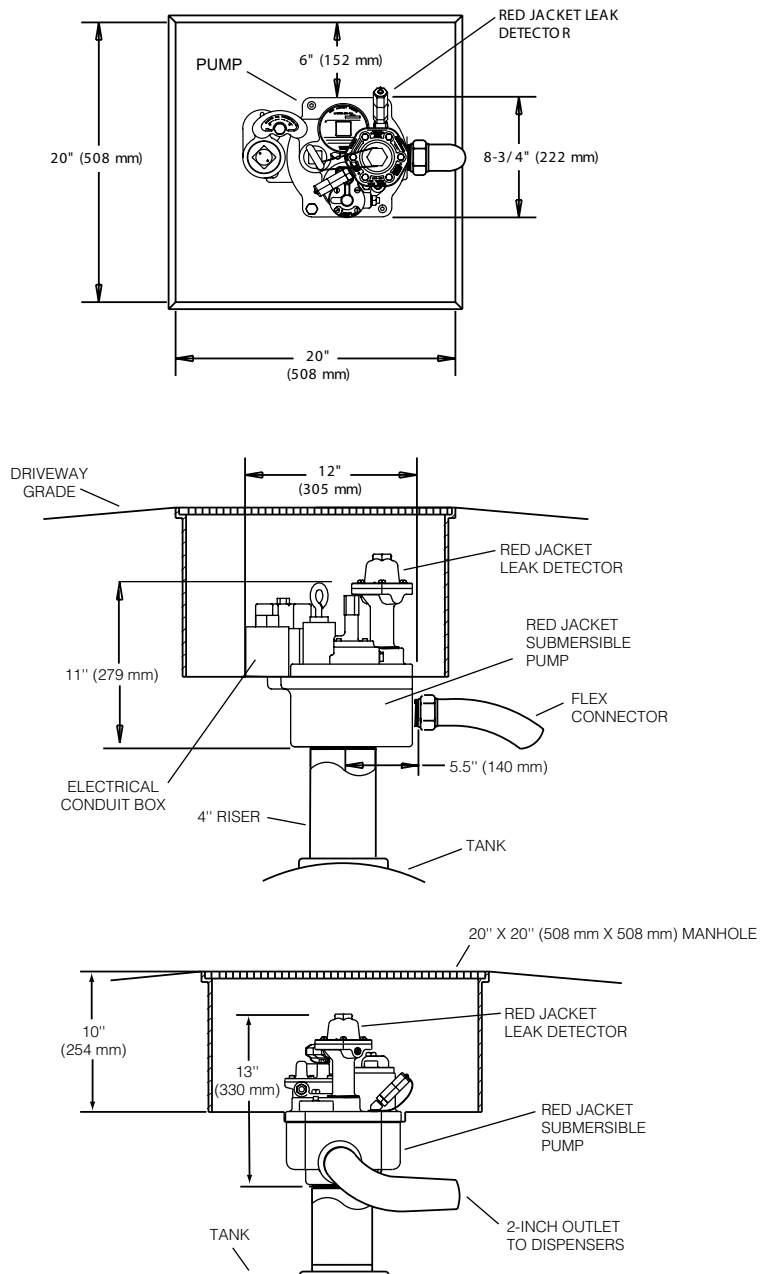

Figure 1.1 Leak detector and manifold dimensions

RECOMMENDED FLOATING SUCTION INSTALLATION

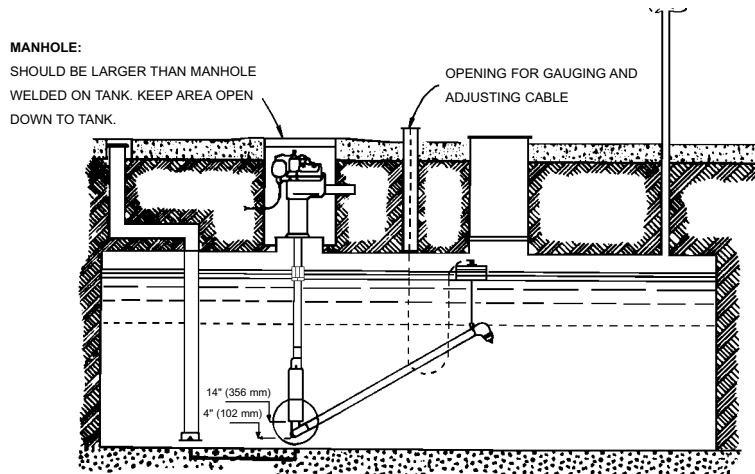

Figure 1.2 Floating suction installation

NOTICE

Distance between center line of pump motor and center line of bottom fill tube should be 3' (914 mm) minimum. Air locking of pump after product delivery may occur at distances less than this.

NOTICE

We supply adapter only; not the apparatus. Floating suction adapter is not available for the X5 Model pump.

- The floating suction arm can be mounted to pump previous to installing in tank.

See example of adaptation to floating suction assembly below.

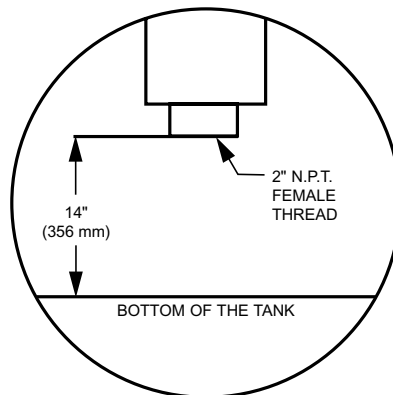

Figure 1.3 Floating Suction Adapter

- Easy service access is provided by unbolting manhole lid through which pump is mounted and removing entire assembly. Use proper thread sealant and insert gasket between flanges of floating suction and pump. This prevents hindrance to pump performance when product level is below this point.

NOTICE

Red Jacket pumps are centrifugal type pumps and as such are not designed to pump product when the level is below the bottom end of the UMP.

4"Petroleum & AG

DIMENSIONS FOR PUMP SELECTION

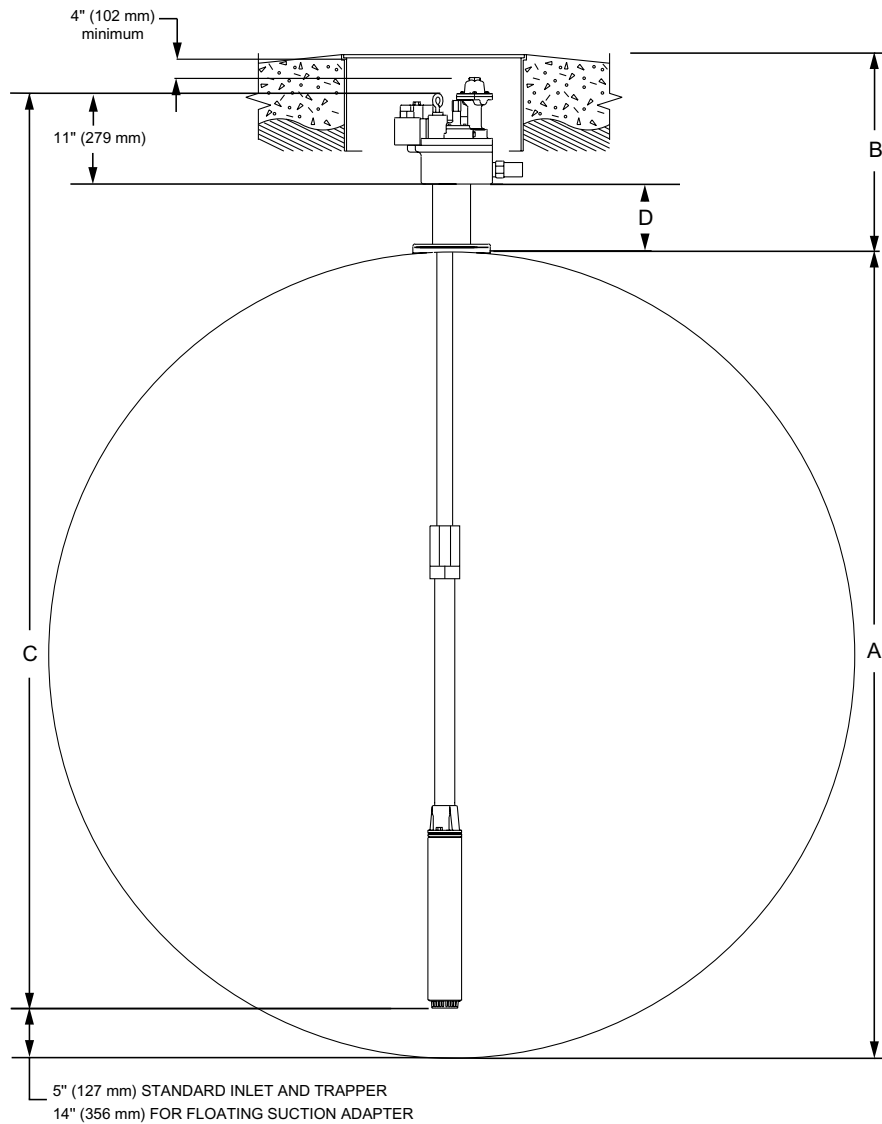

Figure 1.4 Measuring the tank (See TABLE B for adjustment range.)

NOTICE

Distance between center line of pump motor and center line of bottom fill tube should be 3' (914 mm) minimum. Air locking of pump after product delivery may occur at distances less than this.

SPECIFICATIONS

TABLE B: DISTANCE

DISTANCE FROM EYE BOLT TO INLET				
MODEL #	COMPRESSED		EXTENDED	
	in	mm	in	mm
P33R1T1, AGP33R1T1	68.0	1727	95.0	2412
P33R1T2, AGP33R1T2	91.0	2311	125.0	3174
P33R1T3, AGP33R1T3	125.0	3174	192.0	4876
P33R1T4, AGP33R1T4	125.0	3174	159.0	4038
P75S1T1, AGP75S1T1	70.5	1793	97.5	2479
P75S1T2, AGP75S1T2	93.5	2377	127.5	3241
P75S1T3, AGP75S1T3	127.5	3241	194.5	4943
P75S1T4, AGP75S1T4	127.5	3241	161.5	4104
P150S1T1, AGP150S1T1	73.5	1865	100.5	2551
P150S1T2, AGP150S1T2	96.5	2450	130.5	3313
P150S1T3, AGP150S1T3	130.5	3313	197.5	5015
P150S1T4, AGP150S1T4	130.5	3313	164.5	4177
X3P150S1T1, X3AGP150S1T1	74.5	1887	101.5	2573
X3P150S1T2, X3AGP150S1T2	97.5	2471	131.5	3335
X3P150S1T3, X3AGP150S1T3	131.5	3335	198.5	5037
X3P150S1T4, X3AGP150S1T4	131.5	3335	165.5	4199
X5P150S1T1, X5AGP150S1T1	84.0	2132	111.0	2817
X5P150S1T2, X5AGP150S1T2	107.0	2716	141.0	3579
X5P150S1T3, X5AGP150S1T3	141.0	3579	208.0	5281
X5P150S1T4, X5AGP150S1T4	141.0	3579	175.0	4443
P75S3-3T1, AGP75S3-3T1	73.0	1853	100.0	2539
P75S3-3T2, AGP75S3-3T2	96.0	2437	130.0	3301
P75S3-3T3, AGP75S3-3T3	130.0	3301	197.0	5003
P75S3-3T4, AGP75S3-3T4	130.0	3301	164.0	4165
P150S3-3T1, AGP150S3-3T1	75.0	1907	102.0	2592
P150S3-3T2, AGP150S3-3T2	98.0	2491	132.0	3354
P150S3-3T3, AGP150S3-3T3	132.0	3354	199.0	5056
P150S3-3T4, AGP150S3-3T4	132.0	3354	166.0	4218
X4P150S3T1, X4AGP150S3T1	75.5	1920	102.5	2606
X4P150S3T2, X4AGP150S3T2	98.5	2504	132.5	3368
X4P150S3T3, X4AGP150S3T3	132.5	3368	199.5	5073
X4P150S3T4, X4AGP150S3T4	132.5	3368	166.5	4232
P75S17-3T1, AGP75S17-3T1	72.0	1828	99.0	2514
P75S17-3T2, AGP75S17-3T2	95.0	2412	129.0	3276
P75S17-3T3, AGP75S17-3T3	129.0	3276	196.0	4977
P75S17-3T4, AGP75S17-3T4	129.0	3276	163.0	4139
P150S17-3T1, AGP150S17-3T1	74.0	1878	101.0	2564
P150S17-3T2, AGP150S17-3T2	97.0	2462	131.0	3326
P150S17-3T3, AGP150S17-3T3	131.0	3326	198.0	5028
P150S17-3T4, AGP150S17-3T4	131.0	3326	165.0	4189
X4P150S17T1, X4AGP150S17T1	74.5	1892	101.5	2578
X4P150S17T2, X4AGP150S17T2	97.5	2476	131.5	3340
X4P150S17T3, X4AGP150S17T3	131.5	3340	198.5	5041
X4P150S17T4, X4AGP150S17T4	131.5	3340	165.5	4203

4" Petroleum & AG

TABLE C: ELECTRICAL SERVICE INFORMATION

Required power supply rating for 60HZ, 1 phase motors is 208-230VAC. For 50HZ 1 phase motors, required rating is 220-240VAC, 3 phase motors required rating is 380-415 VAC.

ELECTRICAL SERVICE INFORMATION											
UMP Model No.	HP	HZ	PH	Voltage Fluctuation Range		Max. Load Amps	Locked Rotor Amps	Winding Resistance (Ohms)			Capacitor Kit (µF)
				Min.	Max.			Winding Resistance (Ohms)			
								Black-Yellow	Red-Yellow	Black-Red	
AGUMP33R1 UMP33R1	1/3	60	1	200	250	4.0	13.0	8.1-9.9	15.8-19.3	23.8-29.3	144-224-5 (17.5)
AGUMP75S1 UMP75S1	3/4	60	1	200	250	6.5	22.0	2.7-3.3	14.7-18.0	17.3-21.4	144-224-5 (17.5)
AGUMP150S1 UMP150S1	1-1/2	60	1	200	250	10.5	42.0	1.8-2.3	5.3-6.5	6.2-8.9	144-225-5 (25)
X3AGUMP150S1 X3UMP150S1	1-1/2	60	1	200	250	10.5	42.0	1.8-2.3	5.3-6.5	6.2-8.9	144-225-5 (25)
X5AGUMP150S1 X5UMP150S1	1-1/2	60	1	200	250	10.5	42.0	1.8-2.3	5.3-6.5	6.2-8.9	144-225-5 (25)
UMP Model No.	HP	HZ	PH	Voltage Fluctuation Range		Max. Load Amps	Locked Rotor Amps	Winding Resistance (Ohms)			Capacitor Kit (µF)
				Min.	Max.			Winding Resistance (Ohms)			
								Blue-Black	Brown-Black	Blue-Brown	
AGUMP75S3-3 UMP75S3-3	3/4	50	1	200	250	5.8	18.6	3.5-4.3	23.1-28.3	26.5-32.7	144-224-5 (17.5)
AGUMP150S3-3 UMP150S3-3	1-1/2	50	1	200	250	10.0	34.5	2.7-3.4	12.4-15.2	15.0-18.7	144-225-5 (25)
X4AGUMP150S3 X4UMP150S3	1-1/2	50	1	200	250	10.0	34.5	2.7-3.4	12.4-15.2	15.0-18.7	144-225-5 (25)
AGUMP75S17-3 UMP75S17-3	3/4	50	3	342	457	2.2	11.0	26.1-31.9	26.1-31.9	26.1-31.9	---
AGUMP150S17-3 UMP150S17-3	1-1/2	50	3	342	457	3.8	15.8	12.1-14.8	12.1-14.8	12.1-14.8	---
X4AGUMP150S17 X4UMP150S17	1-1/2	50	3	342	457	3.8	15.8	12.1-14.8	12.1-14.8	12.1-14.8	---

TABLE D: WEIGHTS AND LENGTHS

UMP MODEL	HP	LENGTH		WEIGHT	
		in	mm	lb	kg
AGUMP33R1 UMP33R1	1/3	15	380	24	11.0
AGUMP75S1 UMP75S1	3/4	17 1/2	447	28	12.7
AGUMP150S1 UMP150S1	1 1/2	20 1/2	519	34	15.5
X3AGUMP150S1 X3UMP150S1	1 1/2	21 1/4	541	35	15.8
X5AGUMP150S1 X5UMP150S1	1 1/2	31	785	38	17.2
AGP75S3-3	3/4	20	507	30.5	13.9
AGP150S3-3	1 1/2	22 1/4	560	34	15.5
X4AGP150S3	1 1/2	22 3/4	576	35	15.9
AGP75S17-3	3/4	19	482	28	12.7
AGP150S17-3	1 1/2	21	532	31	14.1
X4AGP150S17	1 1/2	21 1/2	547	32	14.5

NOTICE

The weights and lengths listed above are approximate values and will vary due to manufacturing tolerances.

NOTICE

The optional Trapper inlet screen is available as a field installed accessory. The field installed option adds 3.625 inches (92 mm) to the listed values. For installation instructions see Red Jacket literature for #051-256-1. For models with floating suction adapter, add 2.375 inches (59 mm) and 4 lbs (1.8 Kg).

CHAPTER 2: INSTALLATION

INSTALLATION SAFETY NOTICES

ATTENTION INSTALLER: Read this important safety information before beginning work.

DANGER

This product operates in the highly combustible atmosphere of a gasoline storage tank. To protect yourself and others from serious injury, death, or substantial property damage, carefully read and follow all warnings and instructions in this manual.

WARNING

Failure to follow all instructions in proper order can cause personal injury or death. Read all instructions before beginning installation. All installation work must comply with the latest issue of the National Electrical Code (NFPA 70), the Automotive and Marine Service Code (NFPA 30A), and any national, state, and local code requirements that apply.

WARNING

Only trained and qualified personnel may install, program, and troubleshoot Red Jacket equipment. Hazards can cause severe personal injury, death, or substantial property damage if ignored.

WARNING

Before installing pipe threads apply an adequate amount of fresh, UL Classified for petroleum, Non-setting thread sealant.

ATTACHING THE UMP

The UMP is identified by a model number marked on the shell. The Packer/Manifold assembly with attached piping is identified by the catalog number on the capacitor cover nameplate. The catalog number will be followed by T1, T2, T3, or T4 on adjustable length pumps or a four digit number indicating the original pump length in feet and inches (a 9 ft. 6 inch [2896 mm] pump would have 0906 after the model number.)

TABLE E: ATTACHING THE UMP

Packer/Manifold	UMP
AGP33R1 P33R1	AGUMP33R1 UMP33R1
AGP75S1 P75S1	AGUMP75S1 UMP75S1
AGP150S1 P150S1	AGUMP150S1 UMP150S1
X3AGP150S1 X3P150S1	X3AGUMP150S1 X3UMP150S1
X5AGP150S1 X5P150S1	X5AGUMP150S1 X5UMP150S1
AGP75S3-3 P75S3-3	AGUMP75S3-3 UMP75S3-3
AGP150S3-3 P150S3-3	AGUMP150S3-3 UMP150S3-3
X4AGP150S3 X4P150S3	X4AGUMP150S3 X4UMP150S3
AGP75S17-3 P75S17-3	AGP75S17-3 UMP75S17-3
AGP150S17-3 P150S17-3	AGUMP150S17-3 UMP150S17-3
X4AGP150S17 X4P150S17	X4AGUMP150S17 X4UMP150S17

4" Petroleum & AG

The attachment hardware kit to be used to connect the UMP to the Packer/Manifold assembly piping consists of four Grade 8 5/16-18 socket head cap screws, four 5/16 spring lock washers, and one discharge head gasket. It is identified by the kit number 144-328-4 marked on the bag.



Suggested tools (non-sparking): 3/4" wrench, pipe wrench, 1/4" allen wrench, 9/16" wrench, screw driver, wire cutter and wire stripper.

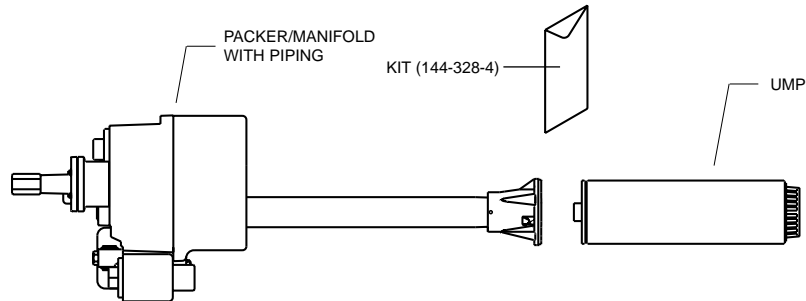

Figure 2.1 Attaching the UMP

- 1: Place the new gasket on the new UMP so that all the holes align.

NOTICE

Gaskets from competitive UMPS will not seal properly and performance will be reduced.

CAUTION

Visually inspect the pigtail connector in the discharge head. Replace if damaged. Be certain the indexing tab of the pigtail is seated in the notch of the discharge head.

- 2: Lubricate the o-ring and pigtail with petroleum based jelly.
- 3: Align the UMP positioning dowel and boss with the proper holes in the discharge head and push the UMP into position using hand force only. The UMP should be snug against the discharge head prior to installing the UMP retaining bolts.

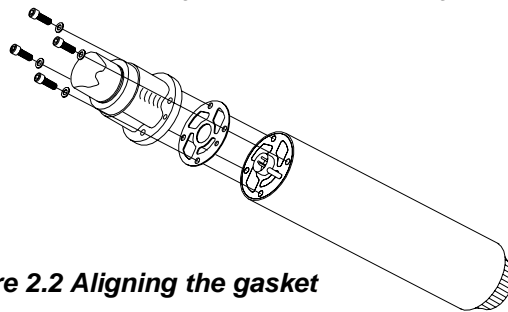

Figure 2.2 Aligning the gasket

NOTICE

Use hand force to put the UMP on the discharge head. If the UMP does not seat properly, snug against the discharge head, remove the UMP and correct the problem.

NOTICE

Do not use the bolts to pull the UMP into position. Use the cross pattern to snug and torque bolts. Do not over torque the bolts. Not following these instructions may cause parts to fail.

- 4: Install the UMP retaining bolts and lock washers. Snug and then torque the bolts using a cross pattern. Torque to 7 ft-lb. (11 N•m).

INSTALLING THE PUMP

NOTICE

Red Jacket petroleum pumps are designed to operate in Class 1, Group D locations.

NOTICE

Specifications and installation instructions may change if the manufacturer recommends changes.

NOTICE

The product temperature must not exceed 105°F (41°C) because the thermal overload protectors in the submersible motors may trip.

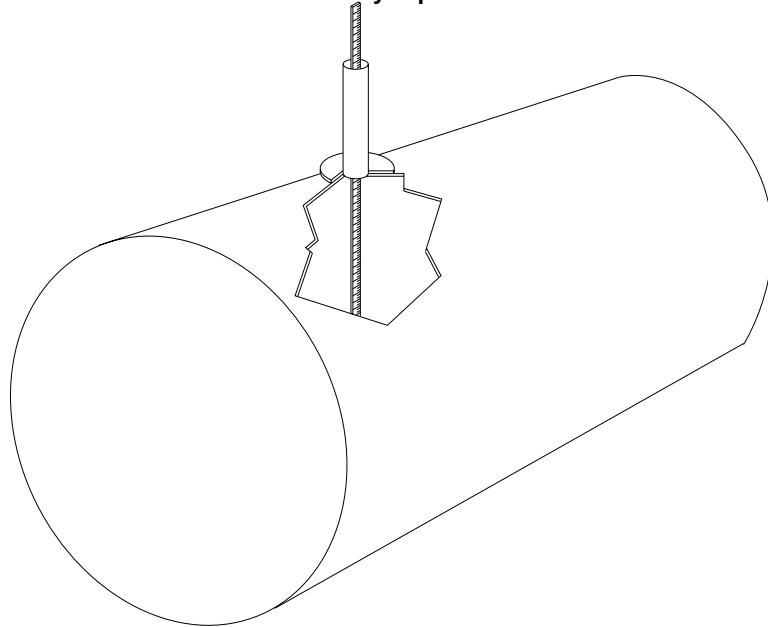

Figure 2.3 Measuring tank

To Install Quick-Set Pump: For Fixed Length Pump Go to Step 7

- 1: Install the riser pipe into the 4-inch tank opening. Use thread sealant. Tighten the riser pipe in the tank until watertight.
- 2: Measure the distance from the bottom of the tank to the top of the 4-inch riser pipe shown in figure 2.3.
- 3: Uncoil the pigtail and lay it flat so it will feed into the packer without knotting or kinking.
- 4: Loosen the clinch assembly, starting by loosening the set screw in the side of the locking nut, then loosen the locking nut.

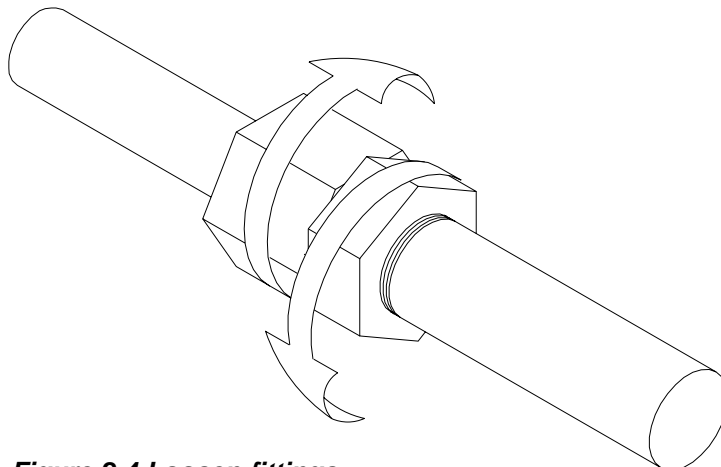

Figure 2.4 Loosen fittings

4" Petroleum & AG

- 5: Pull the UMP end until the distance between the bottom of the manifold and the of the UMP is 5 inches (125 mm) (14 inches (356 mm) for floating suction) shorter than the distance measured in step 2 (see figure 2.5)

NOTICE

If UMP is equipped with floating suction adapter, see recommended floating suction installation in Chapter 1.

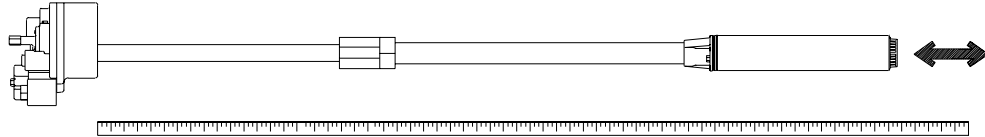

Figure 2.5 Adjust pump length

NOTICE

Take care not to damage the pigtail. If pump is to be adjusted shorter, tension must be kept on pigtail to eliminate kinking.

- 6: Tighten locking nut and torque to 150 ft-lb (200 N•m) minimum, then torque the set screw to 30-35 in-lb (3.5 – 4 N•m).

NOTICE

Return line should be installed on every application to insure against nuisance trips of electronic tank monitoring.

- 7: Attach tubing to barbed fitting, secure with clamp.
- 8: Lay tubing beside column pipe. Cut off 1-3 inches (25-76 mm) above the discharge head.
- 9: Secure tube to column pipe with tie straps. Locate tie straps approximately 6 inches (152 mm) from packer, 6 inches (152 mm) from discharge head and middle of tubing.
- 10: Install the pump onto the riser pipe using thread sealant while making the proper alignment of the manifold and piping. Tighten the manifold until watertight.

For fixed length pump, skip to conduit box wiring

- 11: Remove cover from wiring compartment.
- 12: Pull pigtail wires into wiring compartment.
- 13: Cut pigtail wires extending approximately 8-inches (200 mm) out of wiring compartment.
- 14: Strip back insulation of all wires 3/8-inch (10 mm).
- 15: Using supplied wire nuts, attach like colored pump pigtail wires to wires. See figure 2.6 to verify connections.

- 16: Install excess wire into wiring compartment. Replace wiring compartment cover. Torque to 35 ft-lb (50 N•m). Thread sealant should not be used.
- 17: Install eyebolt plug, use approved non-setting thread sealant and torque to 50 ft-lb (70 N•m).

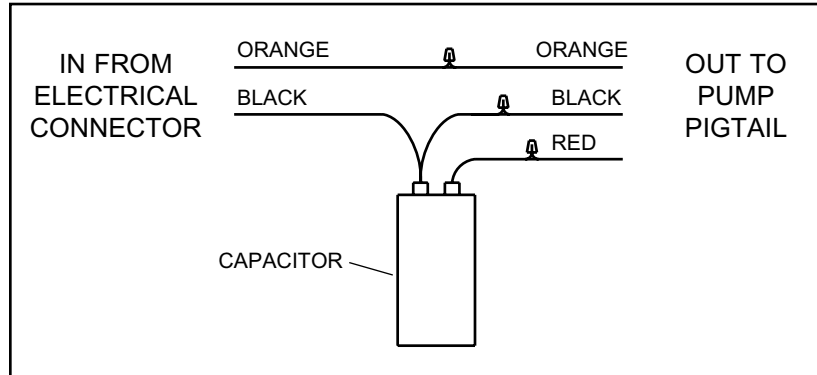

Figure 2.6 Wiring schematic

CONDUIT BOX WIRING

DANGER

ALWAYS DISCONNECT and LOCK or TAG OUT the power before starting to service the pump.

- 1: Connect electrical conduit through approved fittings to conduit box.
- 2: Remove cover from conduit box.
- 3: Connect wires from power supply to wires in the conduit box. Install ground wire as shown if applicable. Replace cover, do not use thread sealant on dual box. Thread sealant required on single box.

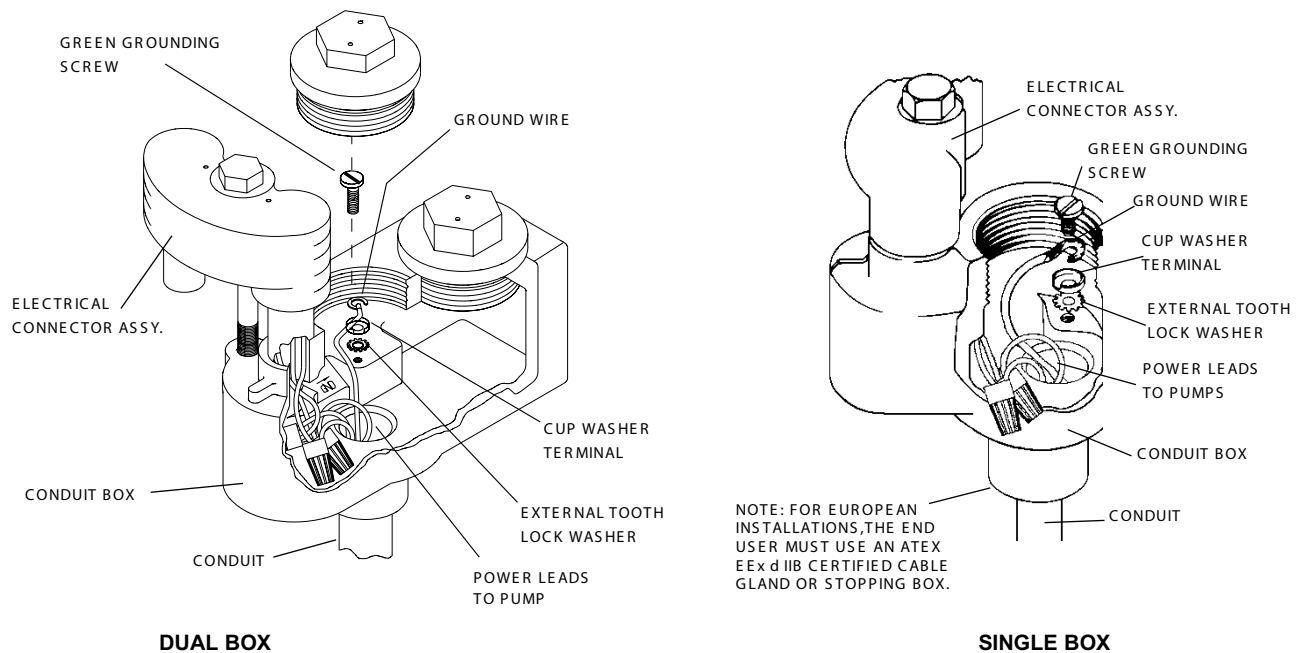

Figure 2.7 Conduit box wiring

230 VAC REMOTE CONTROL BOX WITH 110 VAC COIL UL LISTED, RED JACKET MODEL 880-041-5

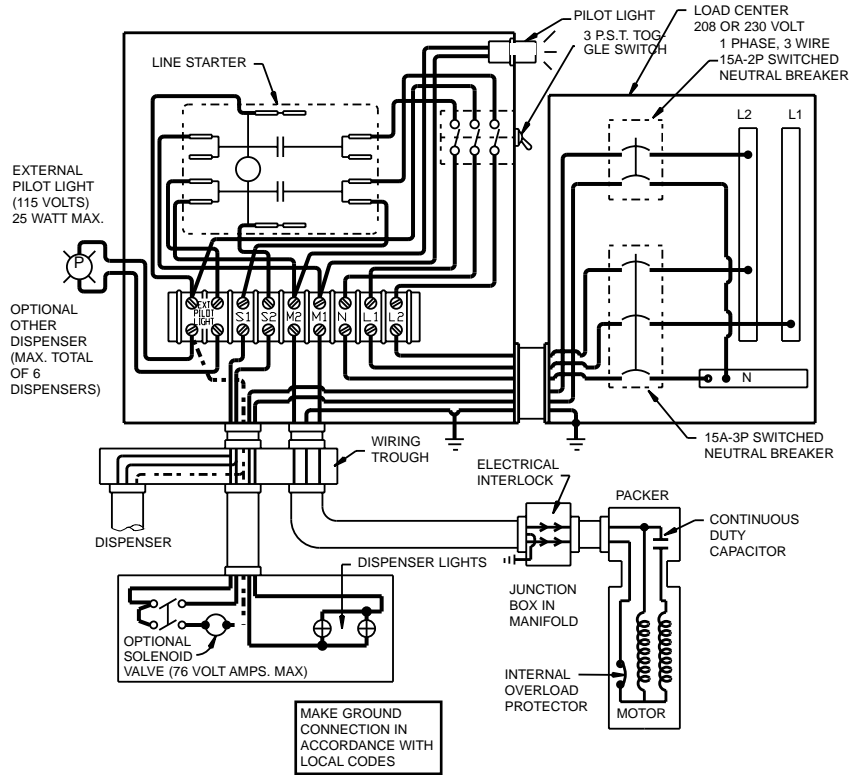
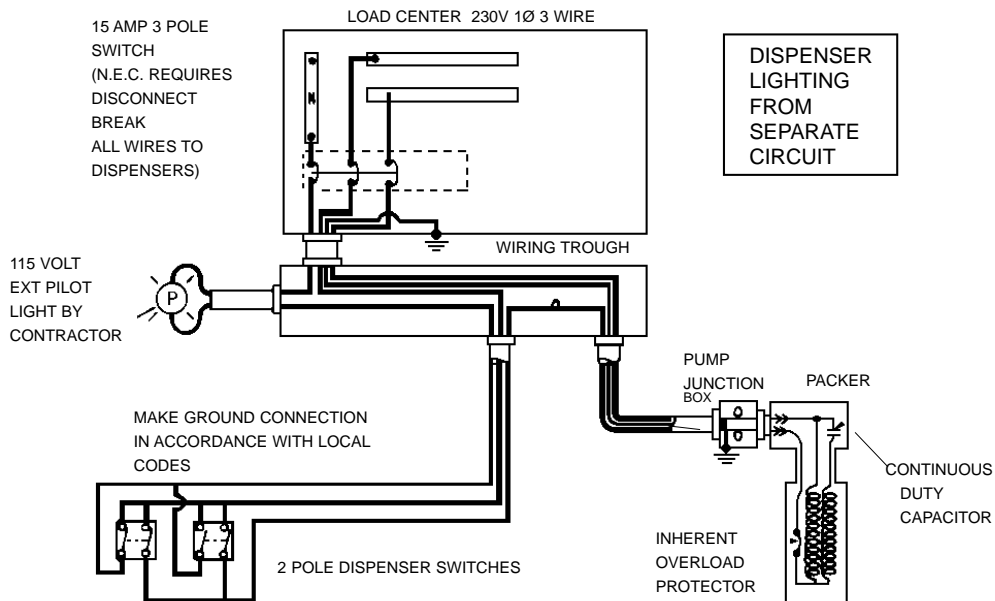

Figure 2.8

SUGGESTED WIRING DIAGRAM WITHOUT OPTIONAL CONTROL BOX



COMBINATION OF 2 POLE DISPENSER SWITCHES OR EXTERNAL PILOT LIGHT.

- RATED FOR TWICE THE FULL LOAD CURRENT OF THE MOTOR:
1/3 HP-8 AMPS, 3/4 HP-13 AMPS, 1-1/2 HP-21 AMPS
- RATED FOR HANDLING LOCKED ROTOR CURRENT OF THE MOTOR:
1/3 HP-13 AMPS, 3/4 HP-22 AMPS, 1-1/2 HP-42 AMPS

Figure 2.9

230 VAC REMOTE CONTROL BOX WITH 110 VAC COIL AND CAPACITOR
UL LISTED, RED JACKET MODEL 880-045-5 (1/3 & 3/4 HP) & 880-046-5 (1-1/2 HP)

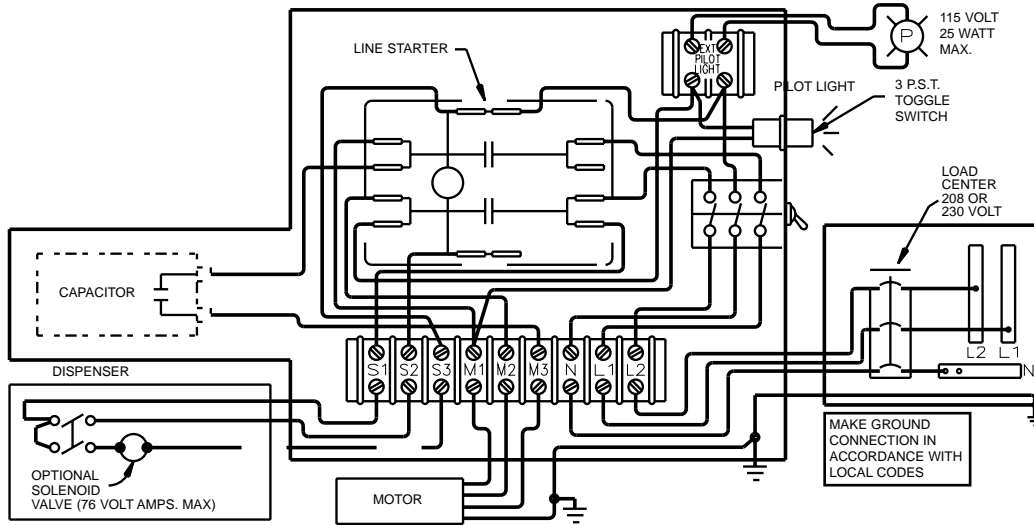

Figure 2.10

230 VAC REMOTE CONTROL BOX WITH 230 VAC COIL
UL LISTED, RED JACKET MODEL 880-042-5

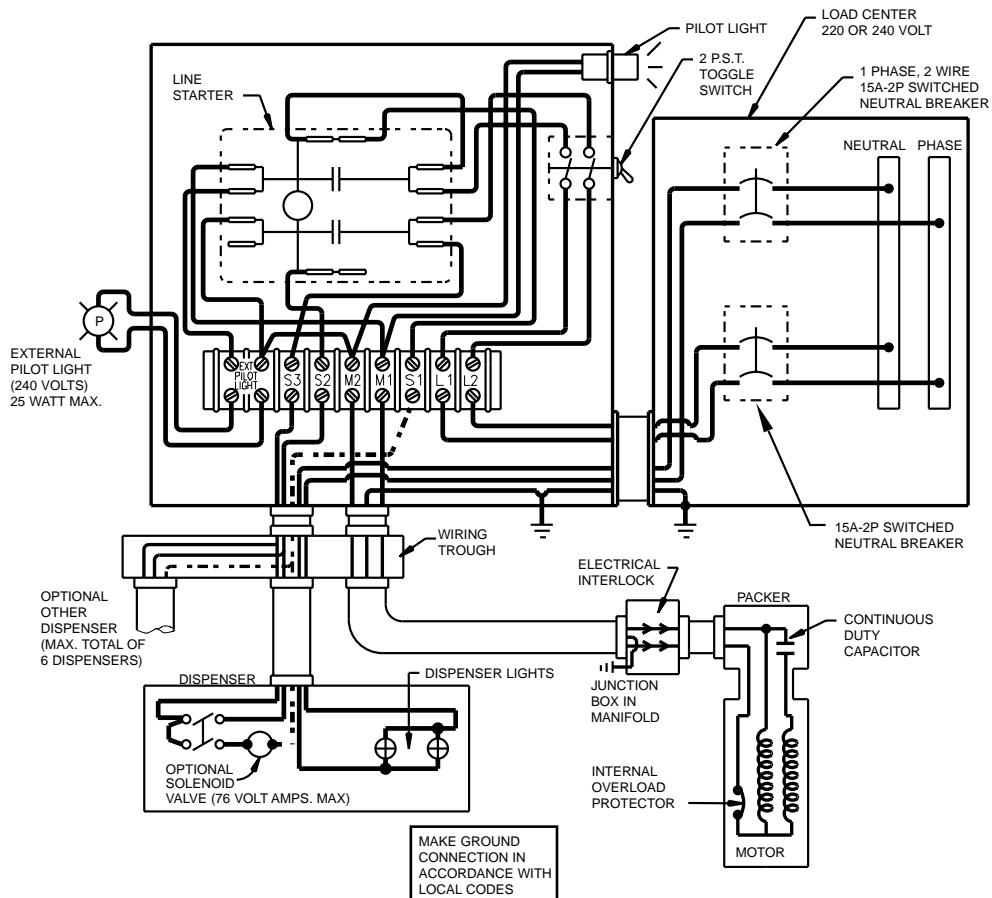

Figure 2.11

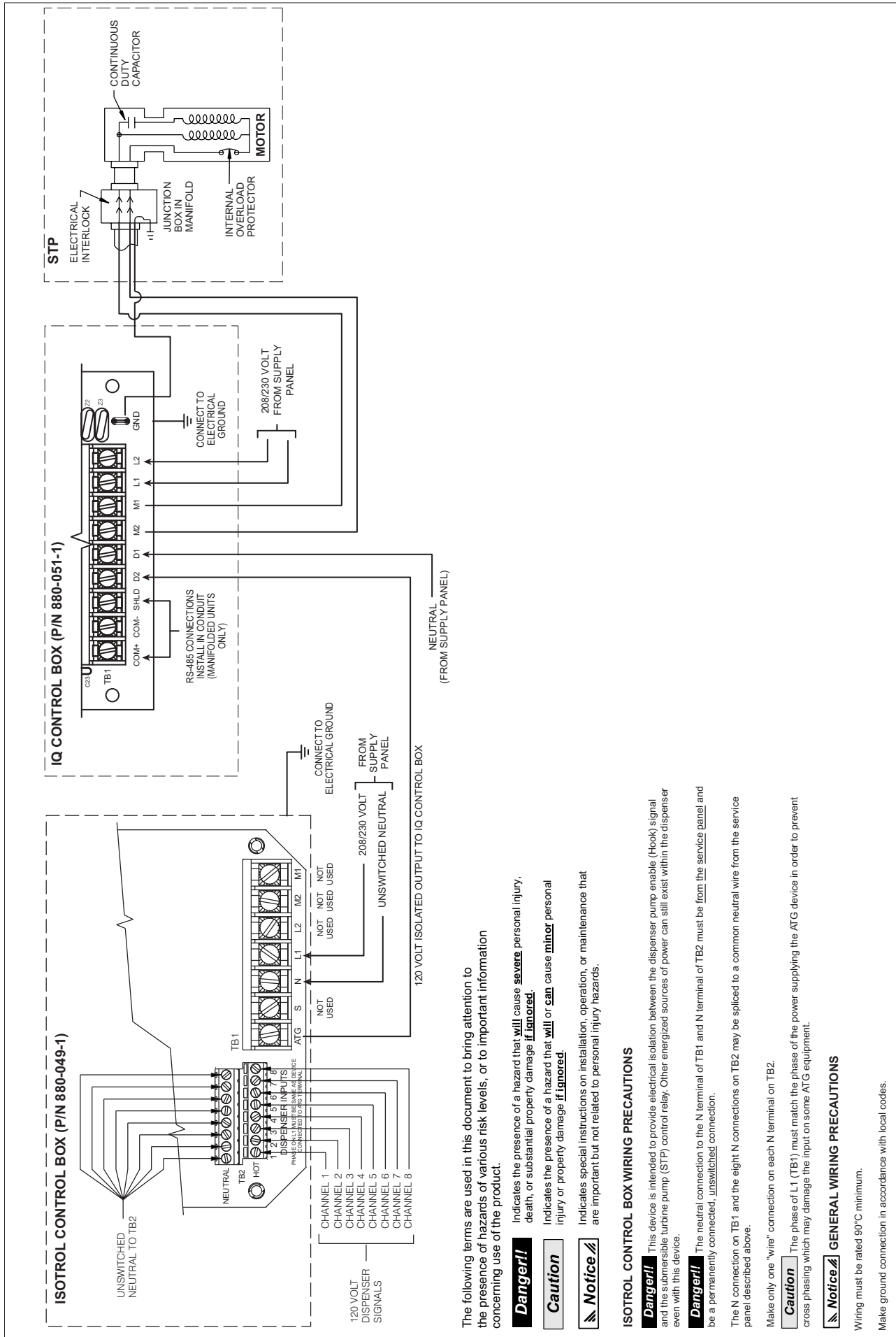

FIGURE 2.11a: ISOTROL TO IQ SYSTEM WIRING - 120 VOLT DISPENSER SIGNALS

The following terms are used in this document to bring attention to the presence of hazards of various risk levels, or to important information concerning use of the product.

- Danger!** Indicates the presence of a hazard that will cause severe personal injury, death, or substantial property damage if ignored.
- Caution** Indicates the presence of a hazard that will or can cause minor personal injury or property damage if ignored.
- Notice** Indicates special instructions on installation, operation, or maintenance that are important but not related to personal injury hazards.

ISOTROL CONTROL BOX WIRING PRECAUTIONS

Danger! This device is intended to provide electrical isolation between the dispenser pump enable (Hook) signal and the submersible turbine pump (STP) control relay. Other energized sources of power can still exist within the dispenser even with this device.

Danger! The neutral connection to the N terminal of TB1 and N terminal of TB2 must be from the service panel and be a permanently connected, unswitched connection.

The N connection on TB1 and the eight N connections on TB2 may be spliced to a common neutral wire from the service panel described above.

Make only one "wire" connection on each N terminal on TB2.

Caution The phase of L1 (TB1) must match the phase of the power supplying the ATG device in order to prevent cross phasing which may damage the input on some ATG equipment.

GENERAL WIRING PRECAUTIONS

Wiring must be rated 90°C minimum.

Make ground connection in accordance with local codes.

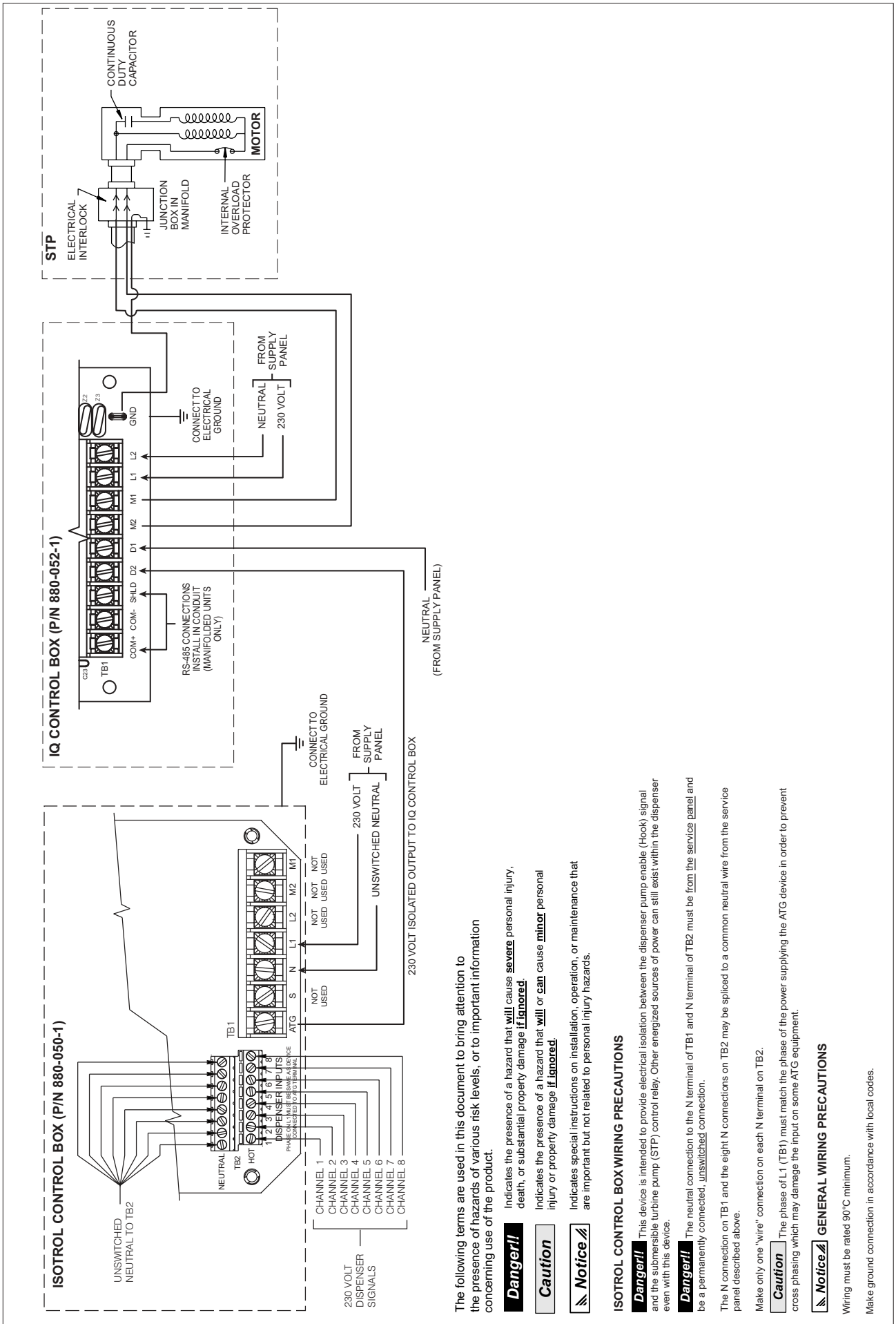

FIGURE 2.11b: ISOTROL TO IQ SYSTEM WIRING - 230 VOLT DISPENSER SIGNALS

The following terms are used in this document to bring attention to the presence of hazards of various risk levels, or to important information concerning use of the product.

- Danger!** Indicates the presence of a hazard that **will** cause **severe** personal injury, death, or substantial property damage **if ignored**.
- Caution** Indicates the presence of a hazard that **will** or **can** cause **minor** personal injury or property damage **if ignored**.
- Notice** Indicates special instructions on installation, operation, or maintenance that are important but not related to personal injury hazards.

ISOTROL CONTROL BOX WIRING PRECAUTIONS

- Danger!** This device is intended to provide electrical isolation between the dispenser pump enable (Hook) signal and the submersible turbine pump (STP) control relay. Other energized sources of power can still exist within the dispenser even with this device.
- Danger!** The neutral connection to the N terminal of TB1 and N terminal of TB2 must be from the service panel and be a permanently connected, unswitched connection.
- The N connection on TB1 and the eight N connections on TB2 may be spliced to a common neutral wire from the service panel described above.
- Make only one "wire" connection on each N terminal on TB2.
- Caution** The phase of L1 (TB1) must match the phase of the power supplying the ATG device in order to prevent cross phasing which may damage the input on some ATG equipment.
- Notice** **GENERAL WIRING PRECAUTIONS**
Wiring must be rated 90°C minimum.
Make ground connection in accordance with local codes.

INSTALLING TWO PUMPS FOR TANDEM OPERATION

When greater flow rates are needed, two pumps may be installed in the same piping system by means of a manifold. If installed according to the illustration below (figure 2.12), tandem systems offer backup support so operations can continue if one pump stops working.

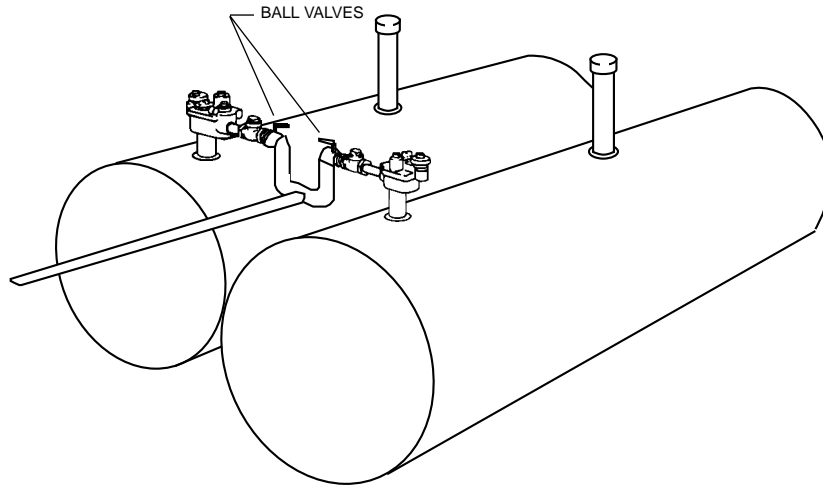

Figure 2.12 Tandem pumps

WARNING

Adjust the Functional Element on both packers to maximum relief pressure by rotating fully clockwise. If maximum pump pressures are NOT a minimum of 5 psi (34 kPa) below the Functional Element relief setting then proper check valves with pressure relief are required to be installed in the discharge line of each pump to prevent product from being pumped through the pressure relief system of the adjacent pump when it is not operating.



The in line check valves and 115 VAC relay are not available from Red Jacket and should be purchased locally. See figure 2.13.



Ball valves should be installed at the pump end of the discharge line for ease of maintenance and troubleshooting. See figure 2.12.

Single Phase

This diagram (Fig 2.13) shows the wiring allowing both submersibles to operate simultaneously with any combination of dispensers turned on. To operate individually, the appropriate toggle switch, located externally on the side of the control box can be turned off manually.

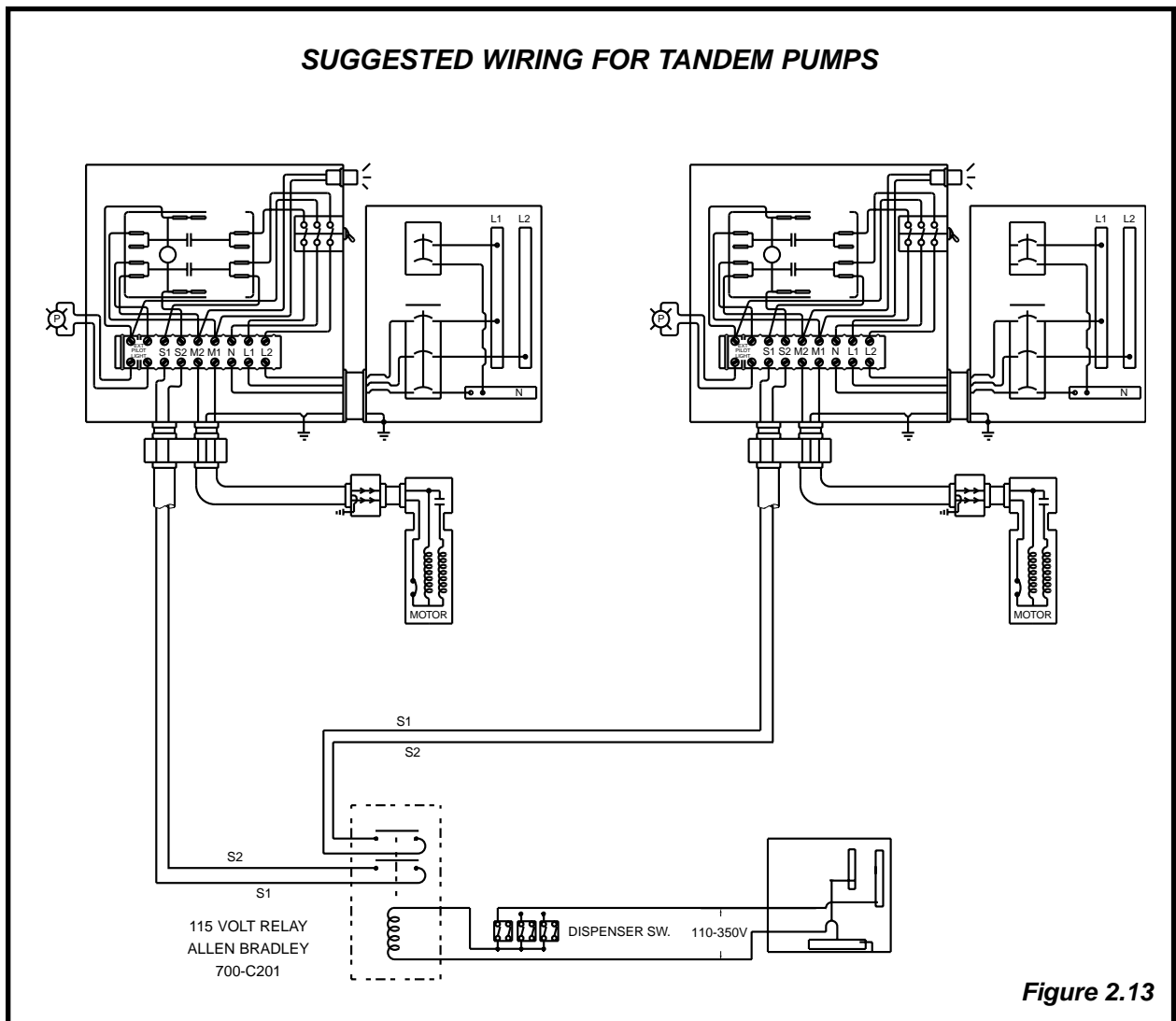

ADJUSTING THE FUNCTIONAL ELEMENT

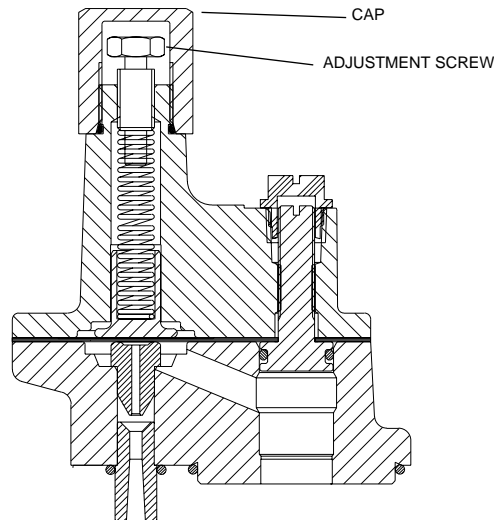

Figure 2.14 Functional Element cap and adjustment screw

DANGER

ALWAYS DISCONNECT and LOCK or TAG OUT the power before starting to service pump.

The Functional Element contained in this package is an adjustable model. All new Functional Elements are factory set at relief pressures of 11.5 (79 kPa) to 16 psi (93 kPa) but can be adjusted to a maximum of approximately 30 psi (207 kPa) by turning down the adjustment screw.

This adjustment feature allows the use of the Red Jacket pump with electronic line leak detection systems that require higher relief pressures and enhances performance of electronic line leak detection systems where field conditions have necessitated minor adjustments to the relief pressure.

To adjust the relief pressure:

- 1: Remove the cap (Fig. 2.14).
- 2: Turn down the adjustment screw (Fig. 2.14). Tightening the screw clockwise will increase the pressure. When the adjusting screw is fully down, the relief pressure is approximately 30 psi (207 kPa). Positions between fully up and fully down will result in relief pressures between approximately 3 psi (21 kPa) and 30 psi (207 kPa).
- 3: Replace cap by turning it until it touches the functional element body. Hand tightening is sufficient as the o-ring completes the seal when it is trapped between the body and cap.

There are two methods to verify the relief pressure setting:

- The pressure reading can be taken from the control unit of an electronic line leak detection system if one is in operation. Observe the pressure that occurs after the pump turns off— this is the adjusted relief pressure.
- Pressure may be observed using a gauge attached at the impact valve or the line test port at the pump. Observe the pressure that occurs after the pump turns off. This is the adjusted relief pressure.

WARNING

When the adjustable functional element is installed, the pump/motor unit must operate at a minimum of 5 psi (34 kPa) greater than the relief (seating) pressure that the functional element has been set to. An improper pressure setting may cause mechanical damage and will void the warranty.

NOTICE

If a siphon system is being utilized, it is especially important to follow the 5 psi (34 kPa) rule, that is, the pump must create 5 psi (34 kPa) more than what the relief pressure has been set to.

For example: If a relief pressure of 25 psi (172 kPa) is desired, the pump in use must be capable of producing 30 psi (207 kPa) minimum.

TABLE F:

RED JACKET PUMP – APPROXIMATE PRESSURE AT SHUT-OFF	
AGUMP33R1 UMP33R1	25 psi (172 kPa) .74 SG @ 60° F (15° C)
AGUMP75S1 UMP75S1	28 psi (193 kPa) .74 SG @ 60° F (15° C)
AGUMP150S1 UMP150S1	30 psi (207 kPa) .74 SG @ 60° F (15° C)
X3AGUMP150S1 X3UMP150S1	43 psi (297 kPa) .74 SG @ 60° F (15° C)
X5AGUMP150S1 X5UMP150S1	46 psi (317 kPa) .74 SG @ 60° F (15° C)
AGUMP75S3-3 UMP75S3-3	30 psi (207 kPa) .74 SG @ 60° F (15° C)
AGUMP150S3-3 UMP150S3-3	32 psi (220 kPa) .74 SG @ 60° F (15° C)
X4AGUMP150S3 X4UMP150S3	40 psi (275 kPa) .74 SG @ 60° F (15° C)
AGUMP75S17-3 UMP75S17-3	29 psi (200 kPa) .74 SG @ 60° F (15° C)
AGUMP150S17-3 UMP150S17-3	32 psi (220 kPa) .74 SG @ 60° F (15° C)
X4AGUMP150S17 X4UMP150S17	39 psi (267 kPa) .74 SG @ 60° F (15° C)

CHAPTER 3: TESTING THE INSTALLATION

NOTICE

ALWAYS DISCONNECT and LOCK or TAG OUT the power before starting to service pump.

To Test Piping

- 1: Block lines at each dispenser. (Trip dispenser shear valve.) Remove line test plug for this test.
- 2: Close pump check valve by turning the vent closing screw as far down as possible. (See Fig 3.1)

CAUTION

Excessive pressure (above normal test pressure of 50–55 psi (345–380 kPa)) may damage check valve seat and other system components.

- 3: Apply line test pressure at line test port. (50 psi (345 kPa) maximum). (See Fig 3.2)

To Test Tank

- 1: Close pump check valve by turning the vent closing screw as far down as possible. Apply tank test pressure at tank test port. (See fig. 3.2)
- 2: After completion of line and/or tank tests, release pressure by turning the vent closing screw as far up as possible.
- 3: After the installation is completed and tests have been made, purge system of air by pumping at least 15 gallons (57 liters) through each dispenser. Begin with the dispenser furthest from pump and work toward the pump.

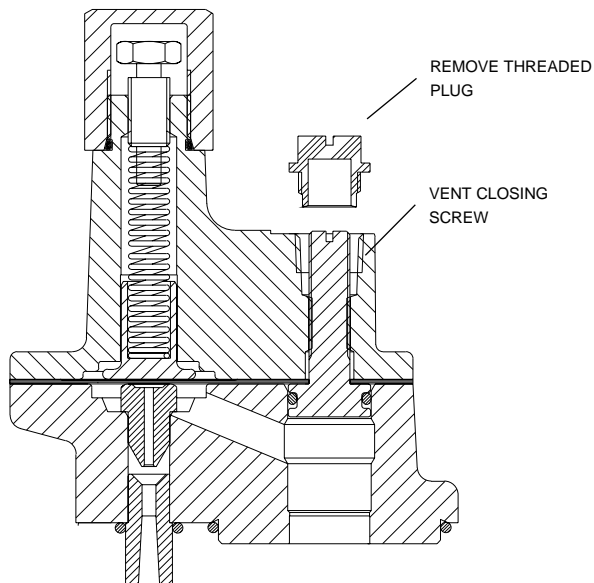

Figure 3.1 Closing the check valve

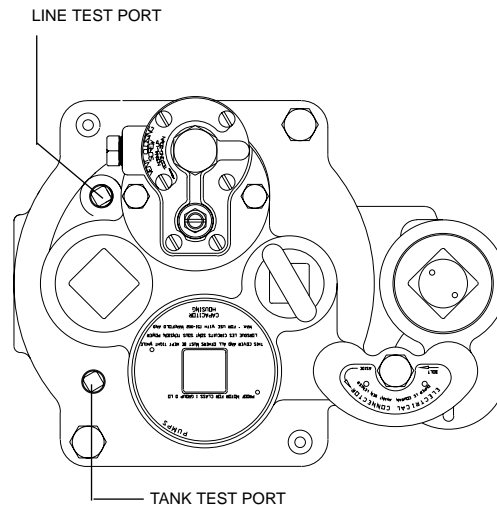

Figure 3.2 Line test port

CHAPTER 4: SERVICE AND REPAIR

TECHNICAL SUPPORT

For technical assistance 24 hours a day, call

1-800-777-2480.

Please have your Red Jacket Technical Support ID number when calling.

See the Parts List on page 28.

REMOVING THE PUMP

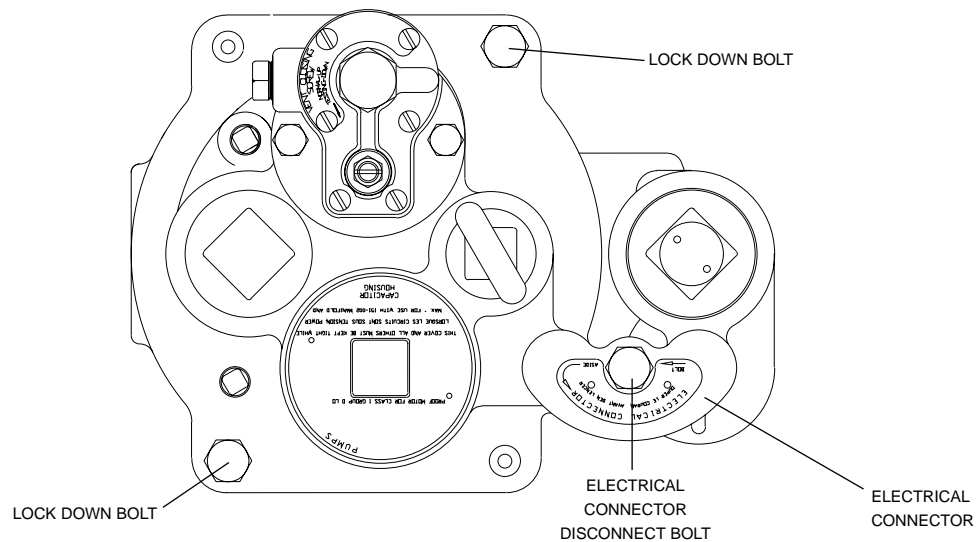

Figure 4.1 Packer

DANGER

ALWAYS DISCONNECT and LOCK or TAG OUT the power before starting to service the pump.

- 1: Back out the electrical connector disconnect bolt. (See fig. 4.1)
- 2: Swing the electrical connector aside.

4" Petroleum & AG

- 3: If a siphon system is in place, disconnect the siphon tubing. If ball valves are installed, close them.
- 4: Remove the two lock-down bolts. To relieve pressure, rock the pump to allow excess pressure to flow into the tank or back out Functional Element screw.
- 5: Lift out the extractable unit.

CAUTION

DO NOT damage the surface above the discharge port. The o-ring below the leak detector port seals on this surface.

NOTICE

Before replacing the extractable portion, make sure that the packer o-ring and discharge o-ring seal surfaces are clean. New o-rings should be installed.

REPLACING THE UMP

DANGER

ALWAYS DISCONNECT and LOCK or TAG OUT the power before starting to service the pump.

- 1: Remove the extractable portion of the old pump from the tank as described in removing the pump.
- 2: Remove the old UMP by removing the four bolts holding the discharge head as shown in figure 4.2.
- 3: Rock the unit while pulling away from the discharge head until it is free.
- 4: Replace the old gasket with a new one provided. Place the new gasket on the new UMP so that all the holes align.

NOTICE

Gaskets from competitive UMPS will not seal properly and performance will be reduced.

CAUTION

Visually inspect the pigtail connector in the discharge head. Replace if damaged. Be certain the indexing tab of the pigtail is seated in the notch of the discharge head

- 5: Lubricate o-ring and pigtail with petroleum based jelly.
- 6: Align the UMP positioning dowel and boss with the proper holes in the discharge head and push the UMP into position using hand force only. The UMP should be snug against the discharge head prior to installing the UMP retaining bolts.

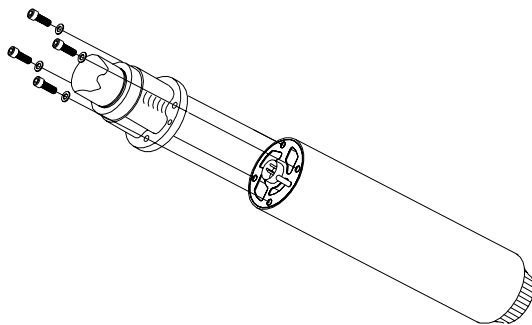

Figure 4.2 Removing the UMP

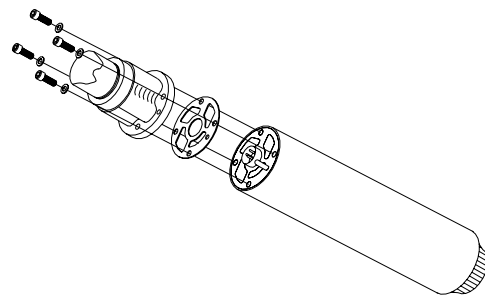

Figure 4.3 Replacing the gasket

NOTICE

Use hand force to put the UMP onto the discharge head. If the UMP does not seat properly, snug against the discharge head, remove the UMP and correct the problem.

NOTICE

Do not use the bolts to pull the UMP into position. Use the cross pattern to snug and torque bolts. Do not over torque the bolts. Not following these instructions may cause parts to fail.

- 7: Install the UMP retaining bolts and lock washers. Snug and then torque the bolts using a cross pattern. Torque to 7 ft-lb.(11 N•m).

NOTICE

Before replacing the extractable, make sure that the surfaces of the packer o-ring and the discharge o-ring seals are clean.

- 8: Replace the packer o-ring and the discharge o-ring seals.
- 9: Reinstall the extractable portion into the tank, using the steps previously described under Installing the Pump in Chapter 2.
- 10: Refer to Chapter 3 to test system.

REPLACING THE FUNCTIONAL ELEMENT

DANGER

ALWAYS DISCONNECT and LOCK or TAG OUT the power before starting to service the pump. Then bleed off any residual pressure from the system.

Disable the Pump

- 1: Back out the electrical connector disconnect bolt. (See fig. 4.4)
- 2: Swing the electrical connector aside.
- 3: To relieve the pressure, back out Functional Element adjustment screw.

Replace the Functional Element

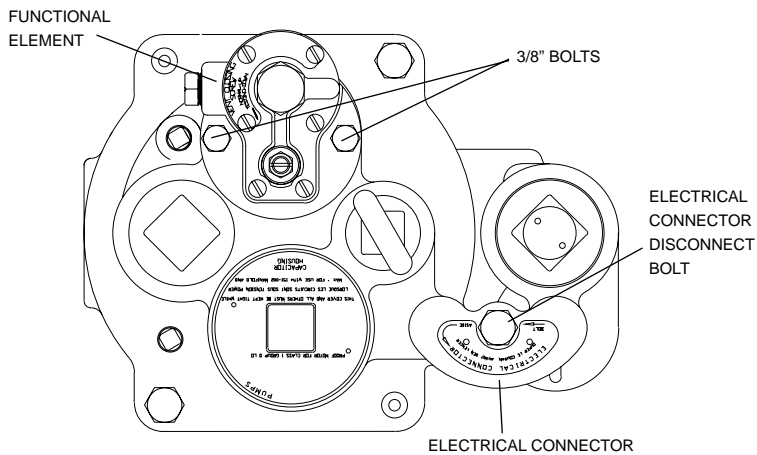

Figure 4.4 Packer with Functional Element

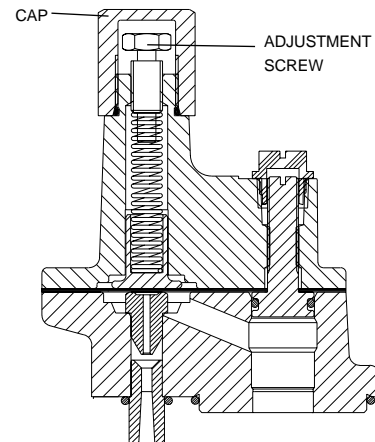

Figure 4.5 Functional Element cap and adjustment screw

- 1: Disconnect the siphon tubing (if siphon is installed).
- 2: Remove the two 3/8" bolts.
- 3: Carefully lift the functional element and remove it from the packer. The old check valve and spring will be resting inside the packer.

4" Petroleum & AG

- 4: Be certain all mating surfaces are clean. Install new functional element o-rings on functional element (see figure 4.5). Install small o-ring in groove of packer. Carefully set new functional element in place. Replace two 3/8" bolts and torque to 20-35 ft lb (27-50 N•m).
- 5: If no siphon is used, make sure the vacuum port on the functional element is plugged with a 3/8" NPT plug.
- 6: Check the seating pressure of the adjustable Functional Element for proper setting.

REPLACING THE CAPACITOR IN PACKER

DANGER

Serious injury or death can result from using a generic-type capacitor. Generic-type capacitors do not contain internal bleed resistors.

DANGER

ALWAYS DISCONNECT and LOCK or TAG OUT the power before starting to service the pump.

NOTICE

Capacitor is 440V, 17.5 μ F continuous duty with internal bleed resistor for 1/3 & 3/4 HP models. Capacitor is 440V, 25 μ F continuous duty with internal bleed resistor for 1-1/2 HP models.

- 1: Remove wiring compartment cover.
- 2: Remove retaining clip
- 3: Pull out capacitor.
- 4: Pull quick connectors.
- 5: Push connectors onto new capacitor.
- 6: Push capacitor into wiring compartment. Clip into place.
- 7: Reinstall capacitor cover. Do not use thread sealant. Torque to 35 ft lb (50 N•m).

INSTALLING A REPLACEMENT EXTRACTABLE PUMP

If fixed length, skip to step 7

- 1: Remove existing Red Jacket pump. (See "Removing the Pump" in Chapter 4).



Make Sure that the packer o-ring and discharge o-ring seal surfaces are clean.

NOTICE

Confirm length of pump prior to installation.

CAUTION

Do not damage the surface above the discharge port. The o-ring below the leak detector port seals on this surface.

- 2: Attach the UMP (see "Attaching the UMP" in Chapter 2)
- 3: Measure the distance from the bottom of the tank to the sealing surface of the manifold.

- 4: Uncoil pigtail and lay flat so it will feed into the packer without knotting or kinking.
- 5: Loosen the clinch assembly, starting by loosening the set screw in the side of the locking nut, then loosen the locking nut.

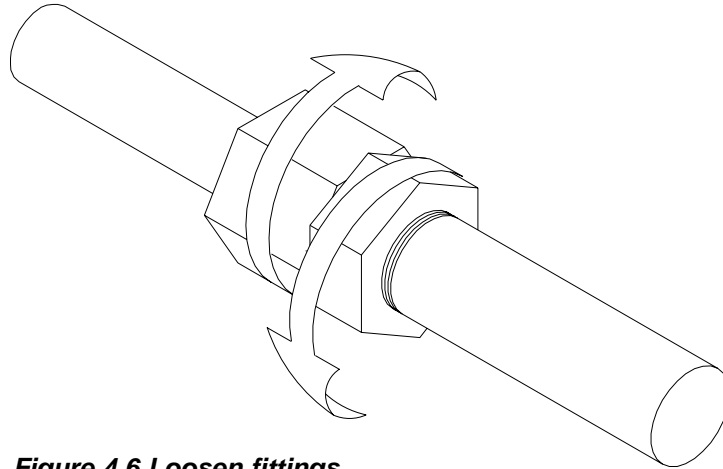

Figure 4.6 Loosen fittings

- 6: Pull the UMP end until the distance between the bottom of the manifold and the of the UMP is 5 inches (125 mm) (14 inches (356 mm) for floating suction) shorter than the distance measured in step 2 (see figure 4.7)

NOTICE

If UMP is equipped with floating suction adapter, see recommended floating suction installation in Chapter 1.



Figure 4.7 Adjust pump length

NOTICE

Take care not to damage the pigtail. If pump is to be adjusted shorter, tension must be kept on pigtail to eliminate kinking.

- 7: Tighten locking nut and torque to 150 ft-lb (200 N•m) minimum, then torque the set screw to 30-35 in-lb (3.5 – 4 N•m).

NOTICE

Return line should be installed on every application to insure against nuisance trips of electronic tank monitoring.

4" Petroleum & AG

- 8: Attach tubing to barbed fitting, secure with clamp.
- 9: Lay tubing beside column pipe. Cut off 1-3 inches (25-76 mm) above the discharge head.
- 10: Secure tube to column pipe with tie straps. Locate tie straps approximately 6 inches (152 mm) from packer, 6 inches (152 mm) from discharge head and middle of tubing.

For fixed length pump, skip to conduit box wiring

- 11: Remove cover from wiring compartment.
- 12: Pull pigtail wires into wiring compartment.
- 13: Cut pigtail wires extending approximately 8-inches (200 mm) out of wiring compartment.
- 14: Strip back insulation of all wires 3/8-inch (10 mm).
- 15: Using supplied wire nuts, attach like colored pump pigtail wires to wires. See figure 4.8 to verify connections.
- 16: Install excess wire into wiring compartment. Replace wiring compartment cover. Torque to 35 ft lb (50 N•m). Thread sealant should not be used.

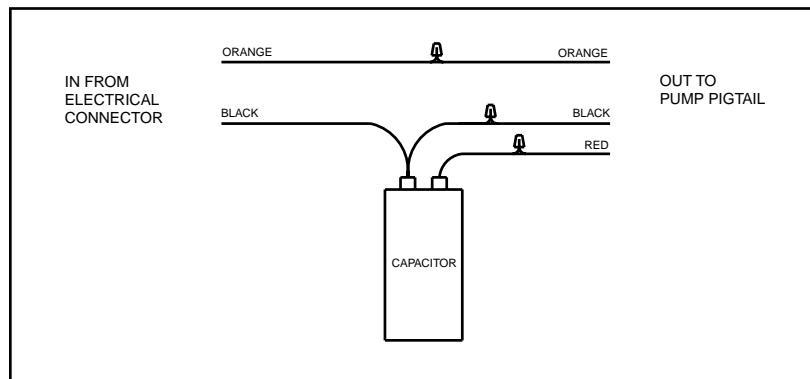

Figure 4.8 Wiring Schematic

- 17: Install the pump into the manifold.

NOTICE

Before replacing the extractable, make sure that the surfaces of the packer o-ring and the discharge o-ring seals are clean.

- 18: Align the positioning dowels of the manifold with the holes in the packer.
- 19: Push the packer as far as possible against the manifold.

20: Insert the lock-down bolts and torque to 45-55 ft lb (61-75 N•m).

21: Loosen the bolts that hold the conduit box to the manifold. Do not remove.

22: Swing the electrical connector into position.

23: Torque the electrical connector bolt to 25-50 ft lb (34-68 N•m).

24: Torque the conduit box bolts to 30-45 ft lb (40-61 N•m).



Suggested tools (non-sparking): 3/4" wrench, pipe wrench, 1/4" allen wrench, 9/16" wrench, screw driver, wire cutter and wire stripper.

PARTS LIST

CUSTOMER SERVICE NUMBER

After unpacking the equipment, please inspect the parts. Make sure all accessories are included and that no damage occurred during shipping. Report any damage to the shipper immediately and inform a customer service representative at **1-800-873-3313** of any **equipment damage** or **missing equipment**.

The following pages list the parts for the functional element, pump, Quick-Set feature, and UMP.

A dash in a table cell indicates the item is not required for that type of pump.

YOKE ASSEMBLY AND CONDUIT BOX PARTS

ITEM	PART #	DESCRIPTION	QTY
1	113-105-5	CONNECTOR — MALE (2-WIRE)	1
1	113-555-5	CONNECTOR — MALE (3-WIRE) (NOT SHOWN)	1
2	072-492-1	RING — SNAP	1
3	313-015-5	CONNECTOR — REPAIR (2-WIRE) AG	1
3	313-021-5	CONNECTOR — REPAIR (3-WIRE) AG (NOT SHOWN)	1
3	313-002-5	CONNECTOR — REPAIR (2-WIRE) PETRO (NOT SHOWN)	1
3	313-019-5	CONNECTOR — REPAIR (3-WIRE) PETRO (NOT SHOWN)	1
4	108-496-5	CONDUIT BOX — SINGLE PETRO	1
4	108-549-5	CONDUIT BOX — SINGLE AG	1

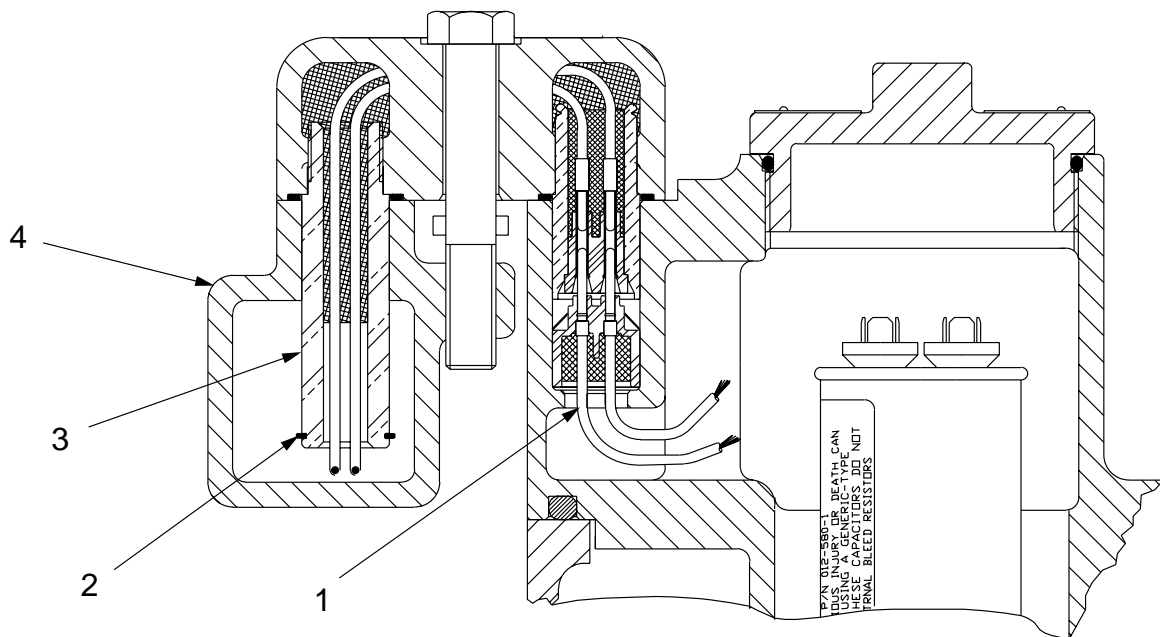

PACKER-MANIFOLD ASSEMBLY PARTS

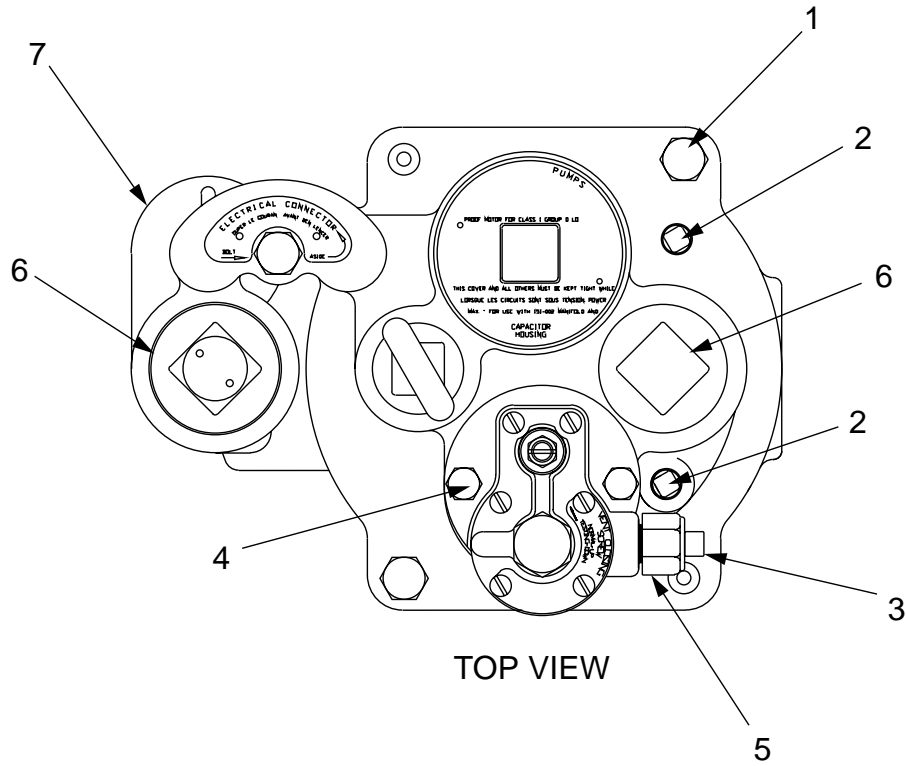

TOP VIEW

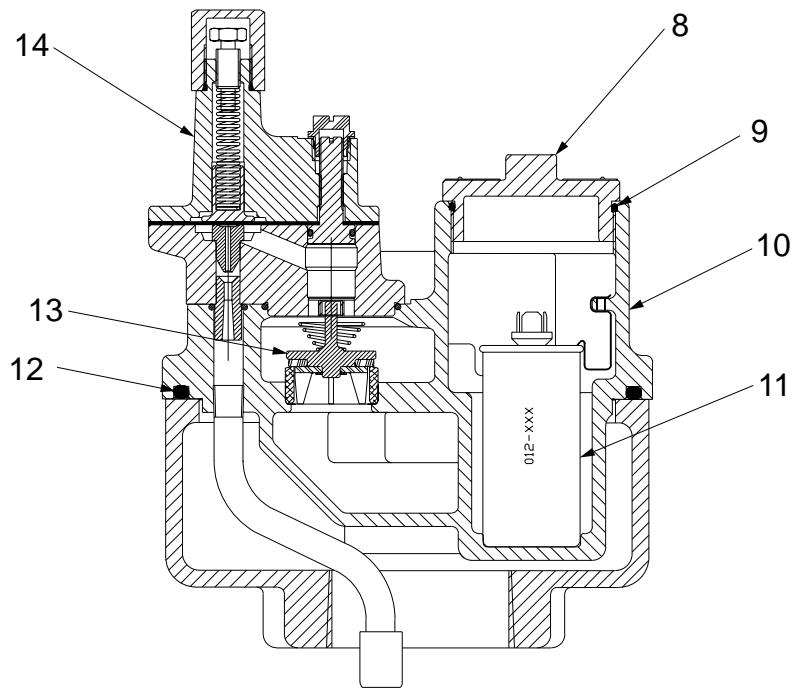

SIDE VIEW

Packer-Manifold Assembly Parts List

ITEM	PART #	DESCRIPTION	DOM	INT'L
1	026-205-1	SCREW — 1/2-13 X 1 1/4 UNC	2	2
2	027-031-1	PLUG — PIPE 1/4" NPT	2	2
3	027-084-1	PLUG — PIPE 3/8" NPT	1	1
4	026-176-1	SCREW — 3/8-16 X 3/4 UNC	2	2
5	288-053-1	SIPHON CHECK VALVE PETRO	1	1
5	188-233-5	SIPHON CHECK VALVE AG	1	1
6	067-281-5	PLUG — ASSY CONDUIT BOX (DUAL BOX OPTION NOT SHOWN)	2	2
6	027-086-3	PLUG — PIPE 2" NPT (SINGLE BOX ONLY)	1	1
7	144-229-5	KIT — 2 WIRE ELECTRICAL CONNECTOR & DUAL CONDUIT BOX PETRO (NOT SHOWN)	1	1
7	144-221-5	KIT — 3 WIRE ELECTRICAL CONNECTOR & DUAL CONDUIT BOX PETRO (NOT SHOWN)	1	1
7	144-222-5	KIT — 3 WIRE ELECTRICAL CONNECTOR & DUAL CONDUIT BOX AG (NOT SHOWN)	1	--
8	113-084-5	P33R1 CAPACITOR COVER WITH O-RING	1	--
8	113-085-5	P75S1 CAPACITOR COVER WITH O-RING	1	--
8	113-319-5	P150S1 CAPACITOR COVER WITH O-RING	1	--
8	113-536-5	X3P150S1 CAPACITOR COVER WITH O-RING	1	--
8	113-537-5	X5P150S1 CAPACITOR COVER WITH O-RING	1	--
8	113-543-5	X4P150S3 CAPACITOR COVER WITH O-RING	--	1
8	113-320-5	P150S3-3 CAPACITOR COVER WITH O-RING	--	1
8	113-479-5	AGP33R1 CAPACITOR COVER WITH O-RING	1	--
8	113-480-5	AGP75S1 CAPACITOR COVER WITH O-RING	1	--
8	113-481-5	AGP150S1 CAPACITOR COVER WITH O-RING	1	--
8	113-538-5	X3AGP150S1 CAPACITOR COVER WITH O-RING	1	--
8	113-539-5	X5AGP150S1 CAPACITOR COVER WITH O-RING	1	--
8	113-544-5	P75S17-3 CAPACITOR COVER WITH O-RING	--	1
8	113-545-5	P150S17-3 CAPACITOR COVER WITH O-RING	--	1
8	113-546-5	X4P150S17 CAPACITOR COVER WITH O-RING	--	1
8	113-599-5	AGP75S3-3 CAPACITOR COVER WITH O-RING	--	1
8	113-600-5	AGP150S3-3 CAPACITOR COVER WITH O-RING	--	1
9	072-190-1	CAPACITOR COVER O-RING BUNA (-233) PETRO	1	1
9	072-543-1	CAPACITOR COVER O-RING VITON (-233) AG	1	1
10	264-138-5	2 WIRE REPLACEMENT PACKER ASSY PETRO	1	1
10	264-142-5	2 WIRE REPLACEMENT PACKER ASSY AG	1	1
10	264-141-5	3 WIRE REPLACEMENT PACKER ASSY PETRO	1	1
11	111-092-5	CAPACITOR 17.5 μ F	1	1
11	111-661-5	CAPACITOR 25 μ F	1	1
12	072-189-1	O-RING — BUNA (-443) PETRO	1	1
12	072-542-1	O-RING — VITON (-443) AG	1	1
13	144-183-5	KIT — CHECK VALVE & SPRING PETRO	1	1
13	144-184-5	KIT — CHECK VALVE & SPRING AG	1	1
14	323-001-5	FUNCTIONAL ELEMENT ASSY PETRO	1	1
14	323-002-5	FUNCTIONAL ELEMENT ASSY AG	1	1

4" Petroleum & AG

PUMP PARTS

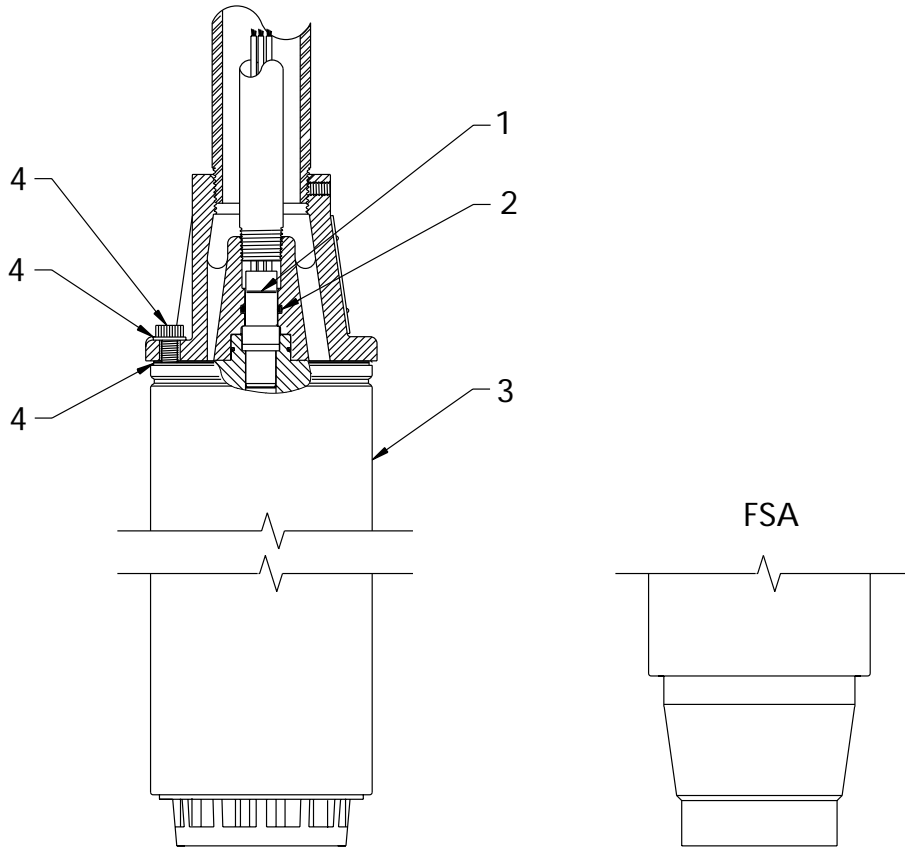

Pump Parts List

ITEM	PART #	DESCRIPTION	DOM	INT'L
1	144-091-5	KIT — PIGTAIL	1	1
2	072-106-1	O-RING BUNA (-113) PETRO	1	1
2	072-528-1	O-RING GFLT (-113) AG	1	1
3	852-004-5	UMP33R1	1	--
3	852-024-5	UMP33R1 W/FSA	1	--
3	852-005-5	UMP75S1	1	--
3	852-025-5	UMP75S1 W/FSA	1	--
3	852-011-5	UMP75S3-3	--	1
3	852-072-5	UMP75S3-3 W/FSA	--	1
3	852-058-5	UMP75S17-3	--	1
3	852-044-5	UMP150S1	1	--
3	852-042-5	UMP150S1 W/FSA	1	--
3	852-048-5	UMP150S3-3	--	1
3	852-073-5	UMP150S3-3 W/FSA	--	1
3	852-059-5	UMP150S17-3	--	1
3	852-118-5	X3UMP150S1	1	--
3	852-133-5	X3UMP150S1 W/FSA	1	--
3	852-153-5	X4UMP150S3	--	1
3	852-154-5	X4UMP150S3 W/FSA	--	1
3	852-155-5	X4UMP150S17	--	1
3	852-156-5	X4UMP150S17 W/FSA	--	1
3	852-116-5	X5UMP150S1	1	--
3	852-083-5	AGUMP33R1	1	--
3	852-134-5	AGUMP33R1 W/FSA	1	--
3	852-084-5	AGUMP75S1	1	--
3	852-135-5	AGUMP75S1 W/FSA	1	--
3	852-107-5	AGUMP75S3-3	--	1
3	852-111-5	AGUMP75S3-3 W/FSA	--	1
3	852-085-5	AGUMP150S1	1	--
3	852-136-5	AGUMP150S1 W/FSA	1	--
3	852-108-5	AGUMP150S3-3	--	1
3	852-112-5	AGUMP150S3-3 W/FSA	--	1
3	852-128-5	X3AGUMP150S1	1	--
3	852-132-5	X3AGUMP150S1 W/FSA	1	--
3	852-124-5	X5AGUMP150S1	1	--
4	144-328-4	KIT — FLEX SYPHON/UMP (INCLUDES GASKET, LOCKWASHERS AND BOLTS)	1	1
--	144-194-5	TRAPPER — RETROFIT (NOT SHOWN)	1	1
--	144-212-5	KIT — REPAIR, QUICK SET O-RING (NOT SHOWN)	1	1

CONTROL BOXES — PART 2

880-045-5 1/3 & 3/4 HP CONTROL BOX W/CAPACITOR (115V COIL)



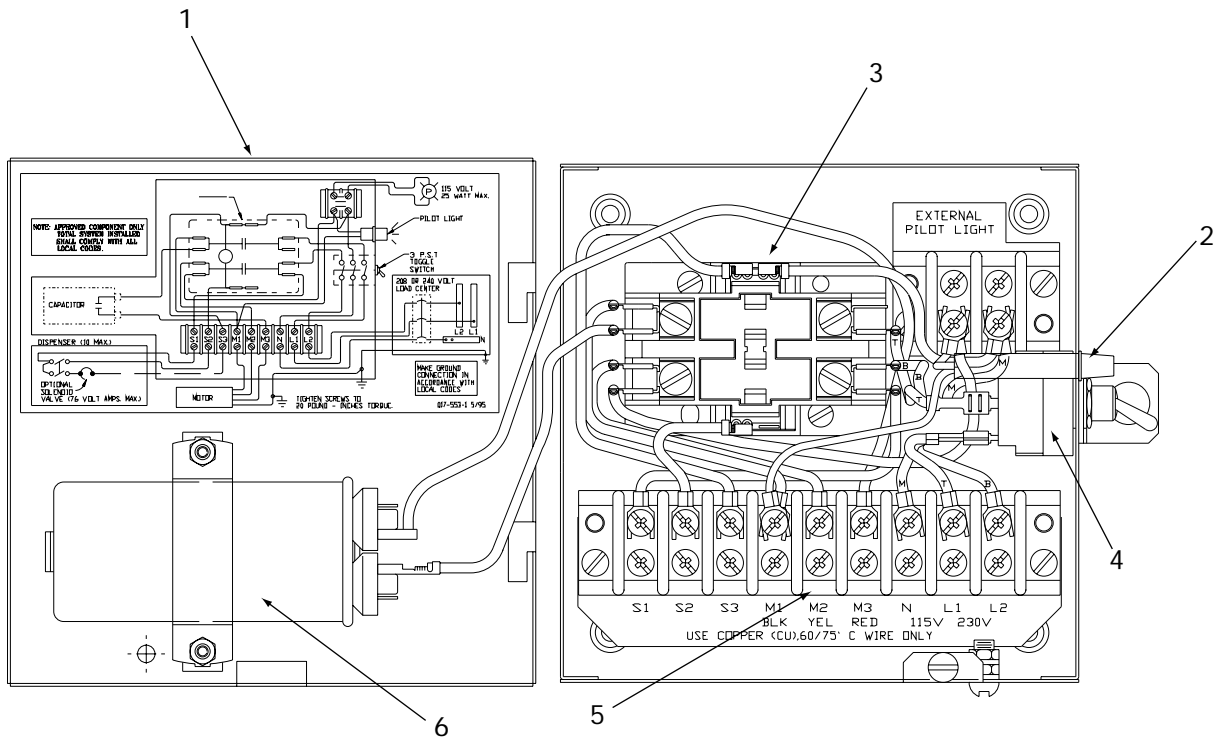

ITEM	PART #	DESCRIPTION	QTY
1	123-141-1	CONTROL BOX	1
2	147-006-1	PILOT LIGHT ASSEMBLY	1
3	014-723-1	LINE CONTACTOR RELAY	1
4	080-858-1	TOGGLE SWITCH	1
5	008-202-1	TERMINAL BLOCK	1
6	111-092-5	CAPACITOR	1

880-046-5 ALL 1-1/2 HP CONTROL BOX W/CAPACITOR (115V COIL)

ITEM	PART #	DESCRIPTION	QTY
1	123-141-1	CONTROL BOX	1
2	147-006-1	PILOT LIGHT ASSEMBLY	1
3	014-723-1	LINE CONTACTOR RELAY	1
4	080-858-1	TOGGLE SWITCH	1
5	008-202-1	TERMINAL BLOCK	1
6	111-661-5	CAPACITOR	1



Appendix A: 4" Standard Red Jacket STP Safety Instructions

1. ATEX Directive 94/9/EC approved Red Jacket Submersible Turbine Pump (STP) marked with the following information defining its limits for safe use.
 - Location Classification:
Market Harborough, U.K. (Assembly Facility)  0539  II2G Altoona, PA U.S.A.  0600  II2G
EEx ds IIA T3
 - Special Conditions for Safe Use:
"The pump motor must not be allowed to run dry. This assembly must be used with appropriately certified equipment that ensures that the motor either remains fully submersed or that there is a continuous presence of fluid inside the pump motor."
 - Certification Number:
DEMKO 03ATEX0237289X
2. For European installations, electrical connections must be made through an ATEX EEx d IIB certified cable gland or stopping box.
3. At installation, initial start-up of this pump requires that the pump motor be fully submersed in fuel.
4. The Red Jacket 4" Standard Submersible Turbine Pump requires no periodic maintenance or calibration.

Declaration of Conformity

Certificate Number: 03ATEX0306558X

Notified Body:

*UL International Demko A/S
P.O. Box 514
Lyskaer 8
DK-2730 Herlev
Denmark*

Products:

Red Jacket 4" Standard Submersible Turbine Pump models. Model designations P with or without prefix X:

*P75S17-3
P150S17-3
X4P150S3-3
X4P150S17-3*

Harmonized Standards:

*EN50014: 1998 – Electrical apparatus for potentially explosive atmospheres - General Requirements
EN50018: 2000 – Electrical apparatus for potentially explosive atmospheres - Flameproof enclosure 'd'
EN50019: 2000 – Electrical apparatus for potentially explosive atmospheres - Increased safety 'e'
EN13463-1: 2001 – Non – electrical equipment for potentially explosive atmospheres - Part 1: Basic method and requirements
SFA3009: 1985 – Special Protection*

The Veeder-Root Company-6th Ave. at Burns Crossing, Altoona, Pennsylvania 16603, U.S.A. declares that the products listed on this declaration are manufactured in accordance with the provisions set forth in the ATEX Directive 94/9/EC and subsequent normative documents as authorized by UL International Demko A/S.

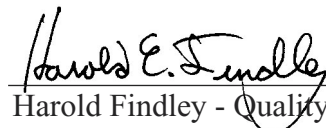
Harold Findley - Quality Manager

Red Jacket

By  **VEEDER-ROOT**

HEADQUARTERS

125 Powder Forest Drive • Simsbury, CT 06070
Tel: (860) 651-2700 • Fax: (860) 651-2719

MANUFACTURING FACILITY

6th Ave. at Burns Crossing • P.O. Box 1673
Altoona, PA U.S.A. 16603
Tel: (814) 695-4476 • Fax: (814) 695-7605