



Series LS-800, LS-800 Adjustable Multi-Station Level Switches

(Includes LS-800's with Temperature Sensors)

Installation Multi-station level switches install vertically in tank top (mounting up) or in tank bottom (mounting down). Level switches will operate normally inclined up to 30°.

Mounting Types

***Note:** Units greater than 72" overall length are supplied with collars with setscrews (made of same material as stem and mounting), in place of float-stop rings. Collars are optional on units less than 72" overall length. Units requiring 316 SS float stops must be special-ordered with 316 SS collars instead of grip rings.

	Type 1 1/2" NPT	Type 2 1-1/4" NPT	Type 3 2" NPT	Type 4 3" Dia., 150# Flange
Stem and Mounting Material	Brass or 316 Stainless Steel			Flange: Carbon Steel or 316 SS Stem: 316 SS
Max. Length (LO)	36"	60"	140"	
Mounting Position	Vertical ±30° Inclination			
*Float Stops (See *Note Above)	Brass Units: Beryllium Copper Grip Rings; Stainless Steel Units: S.S. ARMCO PH-15-7MO Grip Rings			

Type 5 - External Mount

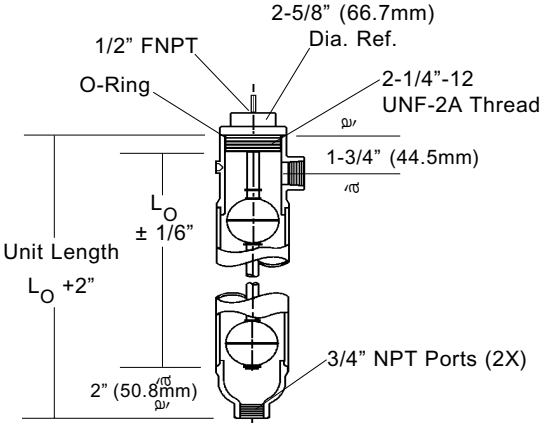

Housing Material	Brass	316 Stainless Steel
Stem & Mounting	Brass	316 Stainless Steel
Port Sizes	3/4" NPT	
Max. Length (LO)	120"	
*Float Stops	Beryllium Copper	S. S. ARMCO PH-15-7 MO

LS-800 Adjustable Mounting

Adjustable mounting is available for LS-800 Series Mounting Types 2, 3, and 4. A special cinch nut on the mounting allows the stem to travel up or down for fine tuning of the actuation points. The extent of adjustment depends on the unit length and the distance from the mounting to the highest float stop.

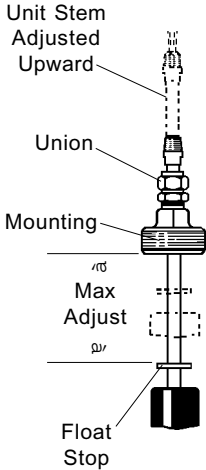

Note

Maximum overall length is limited to 72" with this option.

Installation Procedure for Model LS-802 - Two-Piece Level Switch

1. Unpack unit from shipping crate.
2. Position unit near tank and unstrap stem assemblies.
3. The lower stem section (section with floats) can be inserted into tank to facilitate ease of installation, but must be retained to install upper section.
4. With lower stem in desired position, insert tube coupling from upper stem section into lower section. Tighten coupling nut securely to stem (~ 1 turn past handtight). Check and tighten the upper section nut, if necessary.
5. Cable exiting from the upper section conduit connector can be lightly pulled taught through grommet to prevent excess cable slack in upper stem.
6. Install unit in tank and tighten mounting plug.
7. Connect level switch wires per wiring diagram.

Float Types

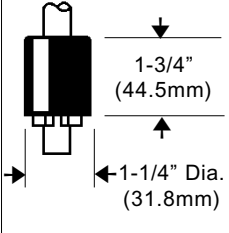
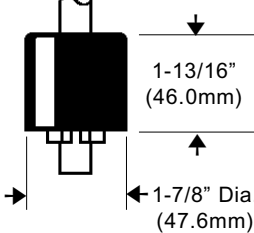
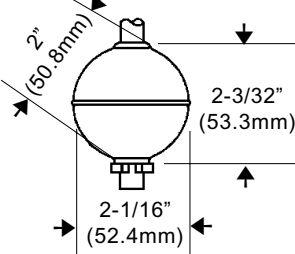
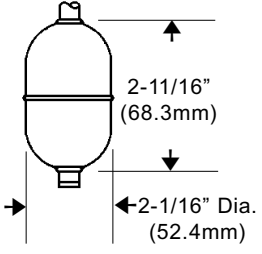
Float Material	Buna N		316 Stainless Steel	
Compatible Mounting Types	2	1, 3, 4, 5	1, 3, 4, 5 (Units <72")	3, 4, 5 (Units >72")
Float Dimensions				
Part Number	26032	10558	14569	15666
Operating Temperature	Water: To 180°F (82.2°C) Oil: -40°F to +230°F (-40°C to 110°C)		-40°F to +300°F (-40°C to +148.9°C)	
Min. Media Specific Gravity	.75	.55	.75	.75

Pressure Ratings Chart

(PSI, Max.)

		Float Part Number			
		26032	10558	14569	15666
Mounting Type	1, 2, 3	150	750	300	
	4	150			
	5	Brass	100 @ +70°F (21.1°C)		
	5	316 S.S.	150	750	300

Wiring Color Codes

SPST Switches				SPDT Switches 20 VA				
Wiring	Group I	Group II		Group III		Group IV		
Com. Wire	Black	None		Black		None		
	NO/NC	Sw. Com.	NO/NC	NO	NC	Sw. Com.	NO	NC
L1	Red	Red	Red	Red	Wh/Red	Red	Wh/Red	Wh/Blk/Red
L2	Yellow	Yellow	Yellow	Yellow	Wh/Yel	Yellow	Wh/Yel	Wh/Blk/Yel
L3	Blue	Blue	Blue	Blue	Wh/Blu	Blue	Wh/Blu	Wh/Blk/Blu
L4	Brown	Brown	Brown	Brown	Wh/Brn	Brown	Wh/Brn	Wh/Blk/Brn
L5	Orange	Orange	Orange	Orange	Wh/Orn	Orange	Wh/Orn	Wh/Blk/Orn
L6	Gray	Gray	Gray	Gray	Wh/Gray	Gray	Wh/Gray	Wh/Blk/Gra

Notes:

- Multi-station units included in shaded areas of chart can be supplied in UL-recognized configurations.
- Wire size is #18 AWG for units of UL-recognized configurations and #22 AWG (Teflon) for non-UL-recognized configurations.
- Units with 50 or 100 VA switches are not UL-recognized.

Electrical Specifications

Switch (N.O. or N.C.):

SPST: 20 VA or 100 VA

SPDT: 20 VA

Lead Wires: #22 AWG, 24" L., Polymeric

Typical Wiring Diagrams

For clarity, only two actuation levels are shown in each group diagram.

**Group I
SPST**



**Group II
SPST**

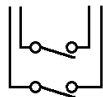

**Group III
SPDT**

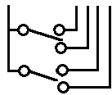

**Group IV
SPDT**

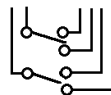

Actuation Level Dimensions

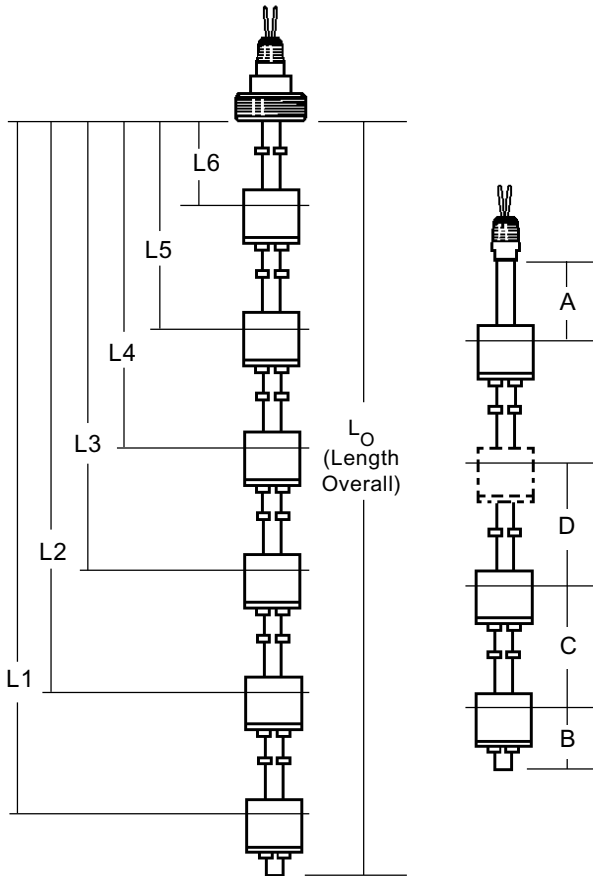

*Actuation level distances and L_0 (overall unit length) are measured from inner surfaces of mounting plug or flange.

** Length Overall $L_0 = L_1 + \text{Dimension B}$. See mounting types for maximum length values.

Switch Ratings - Maximum Resistive Load

VA	Volts	Amps AC	Amps DC
10 General Use	0-50	.2	.13
	120	.08	N.A.
	100	N.A.	.1
20 Pilot Duty	1-30	.4	.3
	120	.17	.13
	240	.08	.06
50 General Use	0-50	0.5	0.5
	120	.4	.4
	240	.2	.2
100*	120	.8**	N.A.
	240	.4	N.A.

* Level switch units with 50 VA and 100 VA switches are not UL recognized or CSA approved.

** Limited to 50,000 operations

Switch actuation levels are determined following the guidelines below:

All units 72" or less length overall with stainless steel or Buna N floats. Also Type 5 units over 72" length overall with Buna N floats:

- A = 1-1/2" minimum distance to highest level (2", Type 5 only)
- B = 2" minimum distance from end of unit to lowest level
- C = 3" minimum distance between levels
- D = 1/4" minimum distance between actuation levels (Note: One float for two levels can be used only when low level is N.C. dry and high level is N.O. dry.)

Types 1, 3, 4 and 5 units with stainless steel float P/N 15666:

- A = 1-5/8" minimum distance to highest level (2", Type 5 only)
- B = 2-1/2" minimum distance from end of unit to lowest level
- C = 4" minimum distance between levels
- D = 1/4" minimum distance between actuation levels (Note: One float for two levels can be used only when low level is N.C. dry and high level is N.O. dry.)

Notes:

1. A, B, and C dimensions are based on liquid specific gravity of 1.0.
2. One float for two levels can be used only when 20VA switch is used.
3. Actuation levels are calibrated on descending fluid level, with water as types for maximum length values. the calibrating fluid, unless otherwise specified.
4. Tolerance on actuation levels is $\pm 1/8"$.

Integrated Temperature Sensors Options

1. Thermistor for Continuous Indication

- 1 Excellent Repeatability

Value: 10,000 ohms @ 77°F (25°C)

Tolerance: ±0.2°C from 32°F to 158°F (0°C to 70°C)

Operating Temperature: 302°F (150°C), Max.

Alpha @ 25°C: -4.39%/°C

Dissipation Constant: 1mW/°C in Still Air
8 mW/°C in Oil Bath

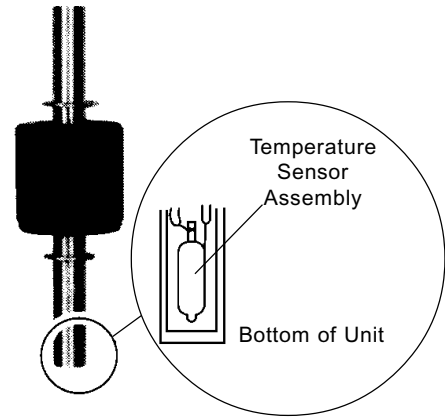

Note

End of unit stem must be submerged a minimum of 2-3/4" for level switch actuation.

2. Thermostat for Switch Action

- 1 Settings from 150°F to 175°F
- 1 Open or close switch on increasing temperature

Note

Contact Gems Sensors for Additional Information.

Typical Wiring Diagram

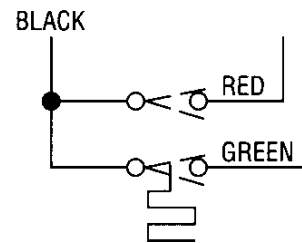

Return Policy

Returns are accepted on stock items up to 30 days from date of order. You must contact our Returns Department for a Return Authorization (RA) number. Return the goods - freight prepaid - in the original container and include original packing slip. C. O. D. returns are not accepted. Gems reserves the right to apply restocking charges.

Tel: 860-793-4357

Fax: 860-793-4563

Important Points:

- Gems products must be maintained and installed in strict accordance with the National Electrical Code and the applicable Gems product instruction Bulletin that covers installation, operation and proper maintenance. Failure to observe this information may result in serious injury or damages.
- For hazardous area applications involving such things as, but not limited to, ignitable mixtures, combustible dust and flammable materials, use an appropriate explosionproof enclosure or intrinsically safe interface device.
- Please adhere to the pressure and temperature limitations shown throughout this catalog for our level and flow sensors. These limitations must not be exceeded. These pressures and temperatures take into consideration possible system surge pressures/temperatures and their frequencies.
- Selection of materials for compatibility with the media is critical to the life and operation of Gems products. Take care in the proper selection of materials of construction, testing is required.
- NSF-approved sensors are made of materials approved for potable water applications according to Standard 61.
- Stainless steel is generally regarded as safe by NSF and FDA.
- Life expectancy of switch contacts varies with application. Contact Gems if life cycle testing is required.
- Ambient temperature changes do affect switch set points, since the gravity of a liquid can vary with temperature.
- Our sensors have been designed to resist shock and vibration. However, shock and vibration should be minimized.
- Filter liquid media containing particulate and/or debris to ensure the proper operation of our products.
- Electrical entries and mounting points in an enclosed tank may require liquid/vapor sealing.
- Our sensors must not be field-repaired.
- Physical damage sustained by product may render it unserviceable.



Gems Sensors Inc.

One Cowles Road
Plainville, CT 06062-1198
Toll-Free: 1-800-378-1600