

EMERGENCY POWER FUEL SYSTEMS

Day Tank Overflow Receiver and Pump M240

Overflow Protection for Single or Multiple Day Tanks



General Description

The M240 Receiver and Pump provides overflow protection for single or multiple day tanks. The receiver is located to allow gravity overflow from the day tanks. Integral level controls operate the high flow pump to return fuel to the bulk storage tank.

The M240 unit includes an OmniPlex 800 Control Panel, or optionally the unit may be controlled by a C900 CentraPlex Master control module. An Earthsafe C230 Motor Starter is also provided for pump safety and control.

The OmniPlex Controller provides Receiver – Pump operation and monitoring with HOA switches and an emergency stop. The OmniPlex screen provides a summary of operating parameters and allows selection of special operating modes. The Controller networks with other system controllers using Ethernet, and directly to Building Management Systems with an option of BACnet, Modbus, Metasys N2, or Lon protocols.

Day Tank Overflow Receiver and Pump M240

Overflow Protection for Single or Multiple Day Tanks

Ordering Information

M240.MM.XX

Day Tank Overflow Receiver and Pump

MM=10	10 GPM
MM=15	15 GPM
MM=20	20 GPM
MM=30	30 GPM

XX=11	120 VAC – 1 PH
XX=21	208 VAC – 1 PH
XX=23	240 VAC – 3 PH
XX=43	480 VAC – 3 PH

M240 Day Tank Overflow Receiver and Pump			
Dimensions	30" L x 18" W x 60" H		
Receiver Capacity	7.5 Gallons Capacity Welded Steel Receiver Level Switches for Pump Start – Stop – High Alarm – Low Alarm		
Flow Capacity (GPM)	10 – 15 – 20 - 30		
Pressure Rating	150 PSI		
Pump Type	Viking Positive Displacement Iron Body Pump		
Motor	Close Coupled TEFC Motor 120 – 208 VAC / 1 Phase 240 – 480 VAC / 3 Phase		
Horsepower	GPM	HP@50 PSI Standard	HP@100 PSI Optional
	10	0.75	1.50
	15	1.00	2.00
	20	1.50	3.00
	30	2.00	4.00
Accessories	Bypass Relief Valve Adjustable Inlet Vacuum Gauge Outlet Pressure Gauge Inlet Check Valve Outlet Ball Valve Motor Starter / Disconnect		
Construction	Welded Steel Construction Industrial Enamel Finish Color RAL7035 Light Gray		
Inlet / Outlet Connections	2.00" FNPT Receiver Inlet 1.00" MNPT Pump Outlet		
Controls	C820 OmniPlex Controller or C900 CentraPlex Master Controller		
Motor Disconnect / Drives	C231 Single Critical Service C233 Single Standard Service C235 SingleVFD Drive		
Optional Equipment	01 Explosion-proof Motor 02 Less OmniPlex Controller (CentraPlex System Control) 03 Add Electronic Meter 04 Add Flow Switch 05 Add Pressure Switch 06 Add Pressure Transd		

Day Tank Overflow Receiver and Pump M240

Overflow Protection for Single or Multiple Day Tanks

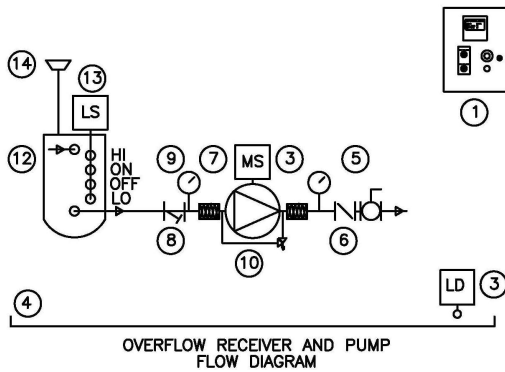

MARK	QTY	DESCRIPTION
1	1	OMNIPLEX CONTROL PANEL
2	1	PUMP CONTROL PANEL
3	1	LEAK SENSOR
4	1	PUMP CONTAINMENT
5	1	BALL VALVE
6	1	CHECK VALVE
7	2	FLEX CONNECTOR
8	1	STRAINER
9	2	PRESSURE / VACUUM GAUGE
10	1	PUMP - MAIN TRANSFER
11	1	PRESSURE RELIEF VALVE
12	1	RECEIVER
13	1	LEVEL SENSOR
14	1	VENT CAP

Overflow Receiver and Pump

The overflow receiver and pump accepts fuel from day tank gravity overflow piping and transfer the fuel under pressure to a remote aboveground or underground primary source tank where gravity return flow is not possible.

The receiver tank is equipped with a 4 point level switch for high level, pump start, pump stop and low level. Upon receipt of the Pump Start signal, the control panel closes an output relay to activate the fuel transfer pump. Upon receipt of the Pump Stop signal the fuel transfer pump stops. The low level sensor provides an alarm at the control panel and acts as a secondary pump stop signal. The high level sensor provides an alarm at the control panel and acts as a secondary pump start signal.

The display indicates: (a) normal or alarm condition, (b) pump active status, (c) alarm indication for high, low, and leak alarms, (d) pump status. A common alarm output relay and a serial data interface are provided for BMS integration.

Earthsafe Systems, Inc.
7553 S. Madison
Willowbrook, IL 60527

T: (630) 794-5100
F: (630) 794-5106

info@earthsafe.com
www.earthsafe.com