

# Chromalox®

## Installation, Operation Maintenance Instructions

and

## RENEWAL PARTS IDENTIFICATION

# Type TLC, TLO, TLS, TLI, KTLC, KTLO, KTLS, KTLI, KBLC, KBLs, BLCK, & BLCS Series Industrial Over-The-Side Immersion Heaters

### SERVICE REFERENCE

DIVISION 4	SECTION TL
SALES REFERENCE (Supersedes PD411-9)	PD411-10
	161-048529-001
DATE	JANUARY, 2006



Type KTLC



Type TLC



Type KBLs

Shown above are Moisture Resistant Terminal Enclosures. Explosion Resistant Terminal Enclosure not shown.

**Note:** Consult factory for specific installation instructions for heaters with additional features not detailed in this installation guide. Such additional features may include thermocouples supplied as a special order modification.

## GENERAL

### Safety Guidelines

The safety and performance of this heater is dependent on proper handling, installation, control and maintenance. As Chromalox can not anticipate all conditions under which this information and heater, or this heater in combination with other manufacturer's products may be used, it is advised that you conduct your own tests to determine the safety and suitability of this heater in combination with other products in your application. Where the consequences of overheating or failure could result in personal injury or property damage, back-up controls and safety devices are essential.

The Safety Alert Symbol: **▲** is found throughout these installation instructions to identify potential hazards that can result in personal injury. The seriousness of the potential risk is identified by one of these three words:

**▲ DANGER** – will result in serious injury or death.

**▲ WARNING** – could result in serious injury or death.

**▲ CAUTION** – may result in minor or moderate injury.

Read and follow these instructions to minimize risks of electric shock or fire. Save these instructions for future reference.

Chromalox Type TLC, TLO, TLS, TLI, KTLC, KTLO, KTLS, KTLI, KBLC, KBLs, BLCK, & BLCS series industrial Over-The-Side immersion heaters are designed for a wide variety of heating applications.

### 1. Heater Construction Characteristics

- A. High quality resistance wire held in place by compacted Magnesium Oxide Refractory or compacted proprietary cement enclosed in a wide variety of sheath materials.
- B. Low to high watt densities.
- C. Standard selection of sheath materials include copper, steel, INCOLOY® alloy and stainless steel. This broad selection of sheath materials will operate successfully in many corrosive solutions.
- D. Riser type construction puts the heat at the bottom inducing natural "stirring action" and evenly distributed temperatures.
- E. Units are available with E1 General Purpose, E4 Moisture Resistant, E2 Explosion/Moisture Resistant and E3 Explosion Resistant terminal enclosures.

**IMPORTANT: It is the responsibility of the purchaser of the heater to make the ultimate choice of sheath material based upon his knowledge of the chemical composition of the corrosive solution, character of the materials entering the solution, and controls which he maintains on the process. CHROMALOX cannot warrant any electric immersion heater against failure by sheath corrosion if such failure is the result of operating conditions beyond our control.**

### ▲ WARNING

**Sheath corrosion can result in a ground fault which, depending upon the solution being heated, can cause an explosion or fire.**

# SPECIFICATIONS

## TLC, TLO, TLS, TLI

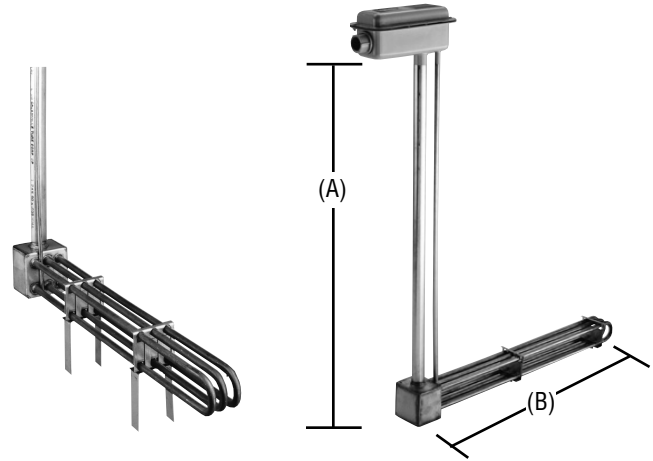
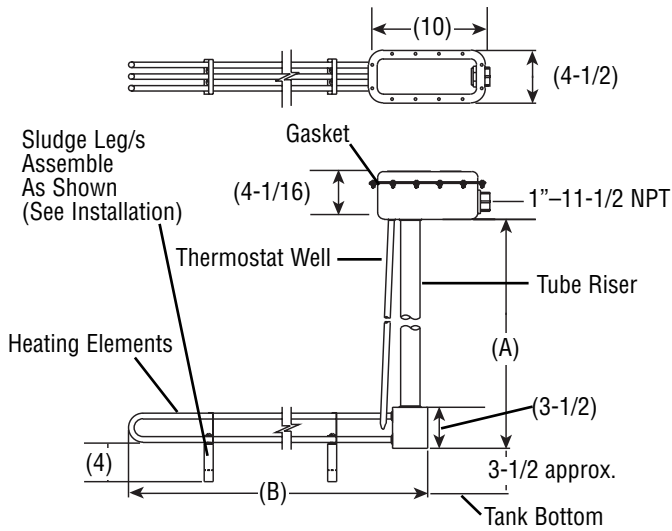

Note: Thermostat shipped separately in kit. See page with renewal parts for ordering information.

### Specifications –

Model	No. Elements	Phase	Volts	kW	Model	No. Elements	Phase	Volts	kW	Sheath Material	Dimensions (In.)	
											(A) Riser Height	(B) Min. Tank Opening Clearance
TLC-210	2	1	240-480	10	TLC-315	3	1 or 3Δ	240-480	15	Copper	48	45
TLC-212	2	1	240-480	12	TLC-318	3	1 or 3Δ	240-480	18	Copper	48	52-1/2
TLC-220	2	1	120-240-480	2	TLC-330	3	1 or 3Δ 1 or 3Y	120-240-480	3	Copper	36	12-1/4
TLC-240	2	1	120-240-480	4	TLC-360	3	1 or 3Δ	120-240-480	6	Copper	36	22-1/4
TLC-260	2	1	120-240-480	6	TLC-390	3	1 or 3Δ	120-240-480	9	Copper	36	29-1/2
TLC-280	2	1	240-480	8	TLC-312	3	1 or 3Δ	240-480	12	Cooper	36, 48	37-3/8
TLI-210	2	1	240-480	10	TLI-315	3	1 or 3Δ	240-480	15	Incoloy	48	45
TLI-212	2	1	240-480	12	TLI-318	3	1 or 3Δ	240-480	18	Incoloy	48	52-1/2
TLI-220	2	1	120-240-480	2	TLI-330	3	1 or 3Δ 1 or 3Y	120-240-480	3	Incoloy	36	12-1/4
TLI-240	2	1	120-240-480	4	TLI-360	3	1 or 3Δ	120-240-480	6	Incoloy	36	22-1/4
TLI-260	2	1	120-240-480	6	TLI-390	3	1 or 3Δ	120-240-480	9	Incoloy	36	29-1/2
TLI-280	2	1	240-480	8	TLI-312	3	1 or 3Δ	240-480	12	Incoloy	36, 48	37-3/8
TLO-220	2	1	120-240-480	2	TLO-330	3	1 or 3Δ	120-240-480	3	Steel	36	22-1/4
TLO-230	2	1	120-240-480	3	TLO-345	3	1 or 3Δ	120-240-480	4.5	Steel	36	29-1/2
TLO-240	2	1	120-240-480	4	TLO-360	3	1 or 3Δ	120-240-480	6	Steel	36, 48	37-3/8
TLO-250	2	1	120-240-480	5	TLO-375	3	1 or 3Δ	120-240-480	7.5	Steel	48	45
TLO-260	2	1	120-240-480	6	TLO-390	3	1 or 3Δ	120-240-480	9	Steel	48	52-1/2
TLO-270	2	1	240-480	7	TLO-310	3	1 or 3Δ	240-480	10	Steel	48	56-1/2
TLS-210	2	1	240-480	10	TLS-315	3	1 or 3Δ	240-480	15	Stainless Steel	48	45
TLS-212	2	1	240-480	12	TLS-318	3	1 or 3Δ	240-480	18	Stainless Steel	48	52-1/2
TLS-220	2	1	120-240-480	2	TLS-330	3	1 or 3Δ 1 or 3Y	120-240-480	3	Stainless Steel	36	12-1/4
TLS-240	2	1	120-240-480	4	TLS-360	3	1 or 3Δ	120-240-480	6	Stainless Steel	36	22-1/4
TLS-260	2	1	120-240-480	6	TLS-390	3	1 or 3Δ	120-240-480	9	Stainless Steel	36	29-1/2
TLS-280	2	1	240-480	8	TLS-312	3	1 or 3Δ	240-480	12	Stainless Steel	36, 48	37-3/8

## SPECIFICATIONS (cont'd.)

### KTLC, KTLI, KTLO, KTLS

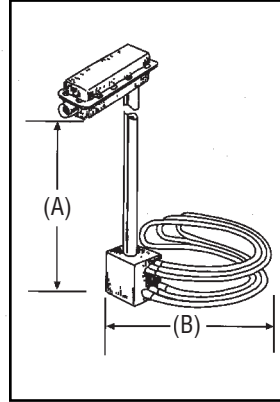
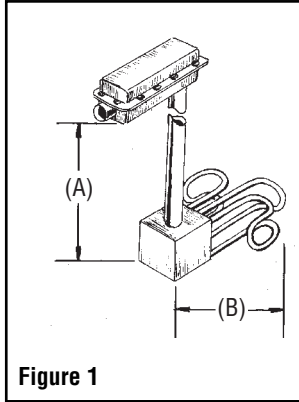
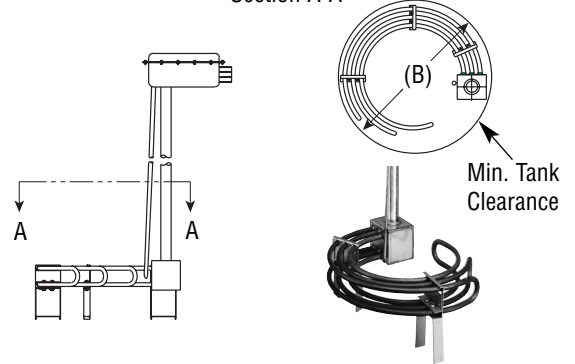

Figure 2

Section A-A



#### Specifications –

Model	No. Elements	Phase	Volts	kW	Model	No. Elements	Phase	Volts	kW	Sheath Material	Dimensions (In.)		Element Arrangement
											(A) Standard Riser Height	(B) Min. Tank Opening Clearance	
KTLC-210	2	1	240-480	10	KTLC-315	3	1 or 3Δ	240-480	15	Copper	48	21-1/4	Fig. 2
KTLC-212	2	1	240-480	12	KTLC-318	3	1 or 3Δ	240-480	18	Copper	48	23-1/2	Fig. 2
KTLC-220	2	1	120-240-480	2	KTLC-330	3	1 or 3Δ 1 or 3Y	120-240-480	3	Copper	36	10-5/8	Fig. 1
KTLC-240	2	1	120-240-480	4	KTLC-360	3	1 or 3Δ	120-240-480	6	Copper	36	13-3/4	Fig. 2
KTLC-260	2	1	120-240-480	6	KTLC-390	3	1 or 3Δ	120-240-480	9	Copper	36	16-1/8	Fig. 2
KTLC-280	2	1	240-480	8	KTLC-312	3	1 or 3Δ	240-480	12	Cooper	36, 48	18-5/8	Fig. 2
KTLC-210	2	1	240-480	10	KTLC-315	3	1 or 3Δ	240-480	15	Incoloy	48	21-1/4	Fig. 2
KTLC-212	2	1	240-480	12	KTLC-318	3	1 or 3Δ	240-480	18	Incoloy	48	23-1/2	Fig. 2
KTLC-220	2	1	120-240-480	2	KTLC-330	3	1 or 3Δ 1 or 3Y	120-240-480	3	Incoloy	36	10-5/8	Fig. 1
KTLC-240	2	1	120-240-480	4	KTLC-360	3	1 or 3Δ	120-240-480	6	Incoloy	36	13-3/4	Fig. 2
KTLC-260	2	1	120-240-480	6	KTLC-390	3	1 or 3Δ	120-240-480	9	Incoloy	36	16-1/8	Fig. 2
KTLC-280	2	1	240-480	8	KTLC-312	3	1 or 3Δ	240-480	12	Incoloy	36, 48	18-5/8	Fig. 2
KTLC-220	2	1	120-240-480	2	KTLC-330	3	1 or 3Δ	120-240-480	3	Steel	36	13-3/4	Fig. 2
KTLC-230	2	1	120-240-480	3	KTLC-345	3	1 or 3Δ	120-240-480	4.5	Steel	36	16-1/8	Fig. 2
KTLC-240	2	1	120-240-480	4	KTLC-360	3	1 or 3Δ	120-240-480	6	Steel	36, 48	18-5/8	Fig. 2
KTLC-250	2	1	120-240-480	5	KTLC-375	3	1 or 3Δ	120-240-480	7.5	Steel	48	21-1/4	Fig. 2
KTLC-260	2	1	120-240-480	6	KTLC-390	3	1 or 3Δ	120-240-480	9	Steel	48	23-1/2	Fig. 2
KTLC-270	2	1	240-480	7	KTLC-310	3	1 or 3Δ	240-480	10	Steel	48	24-7/8	Fig. 2
KTLC-210	2	1	240-480	10	KTLC-315	3	1 or 3Δ	240-480	15	Stainless Steel	48	21-1/4	Fig. 2
KTLC-212	2	1	240-480	12	KTLC-318	3	1 or 3Δ	240-480	18	Stainless Steel	48	23-1/2	Fig. 2
KTLC-220	2	1	120-240-480	2	KTLC-330	3	1 or 3Δ 1 or 3Y	120-240-480	3	Stainless Steel	36	10-5/8	Fig. 1
KTLC-240	2	1	120-240-480	4	KTLC-360	3	1 or 3Δ	120-240-480	6	Stainless Steel	36	13-3/4	Fig. 2
KTLC-260	2	1	120-240-480	6	KTLC-390	3	1 or 3Δ	120-240-480	9	Stainless Steel	36	16-1/8	Fig. 2
KTLC-280	2	1	240-480	8	KTLC-312	3	1 or 3Δ	240-480	12	Stainless Steel	36, 48	18-5/8	Fig. 2

### KBLC, KBLs

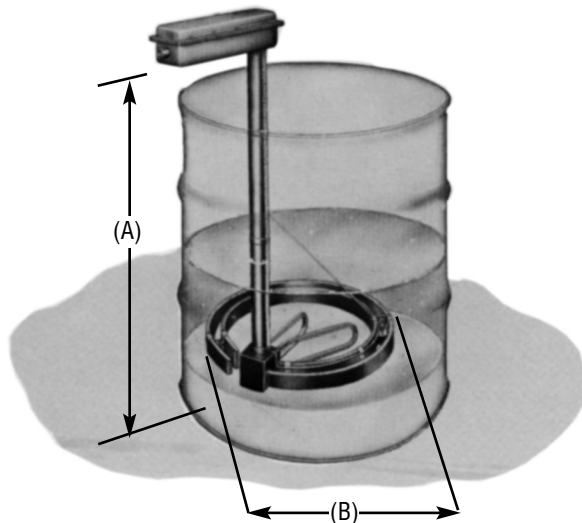

#### Specifications –

Model	Volts	Kw (11 WPSI)	DIMENSIONS Inches	
			(A) Riser Height	(B) Min. Opening Clearance
<b>Type KBLC – Steel Construction</b>				
KBLC-24	120 or 240	2.2	36	12-3/4
KBLC-24T2	120 or 240	2.2	36	12-3/4
KBLC-24T3	120 or 240	2.2	36	12-3/4
KBLC-28	240 only	4.4	36	17-3/4
KBLC-28T2	240 only	4.4	36	17-3/4
KBLC-28T3	240 only	4.4	36	17-3/4
<b>Type KBLs – Stainless Steel Construction</b>				
KBLs-244	120 or 240	2.2	36	12-3/4
KBLs-244T1	120 or 240	2.2	36	12-3/4
KBLs-244T2	120 or 240	2.2	36	12-3/4
KBLs-244T3	120 or 240	2.2	36	12-3/4
KBLs-288	240 only	4.4	36	17-3/4
KBLs-288T1	240 only	4.4	36	17-3/4
KBLs-288T2	240 only	4.4	36	17-3/4
KBLs-288T3	240 only	4.4	36	17-3/4

## SPECIFICATIONS (cont'd.)

### BLCK, BLCS

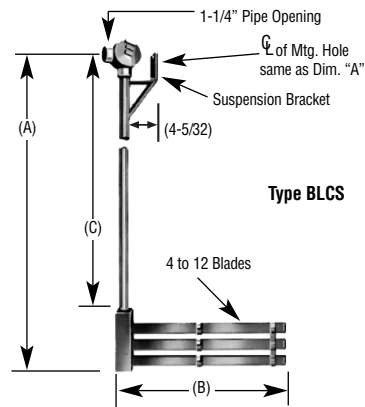
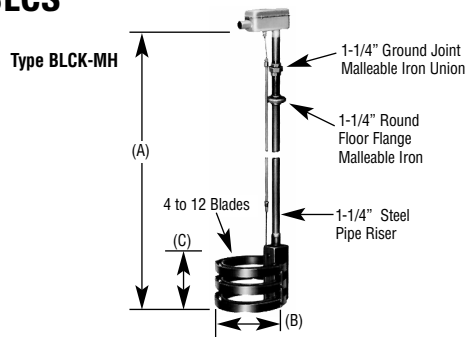

#### Specifications –

Model	No. Blades	Phase	Kilowatts			Voltage	Dimensions (In.)		
			Regular Oil 18 W/in <sup>2</sup>	Fuel Oil 12 W/in <sup>2</sup>	40 W/in <sup>2</sup>		(A) Riser Height	(B) Min. Tank Opening Clearance	(C)
BLCK-MH618	6	1 or 3 Δ	12	7.5	–	240 or 480	144	16-1/2	8-7/8
BLCK-MH824	8	1 or 3 Δ	16	10	–	240 or 480	144	16-1/2	12
BLCK-MH103	10	1 or 3 Δ	20	12.5	–	240 or 480	144	16-1/2	15-1/8
BLCK-MH236	12	1 or 3 Δ	24	15	–	240 or 480	144	16-1/2	18-1/4
BLCS-618	6	1 or 3 Δ	12	7.5	–	240 or 480	144	34	8-7/8
BLCS-824	8	1 or 3 Δ	16	10	–	240 or 480	144	34	12
BLCS-1030	10	1 or 3 Δ	20	12.5	–	240 or 480	144	34	15-1/8
BLCS-1236	12	1 or 3 Δ	24	15	–	240 or 480	144	34	18-1/4

### ⚠ WARNING

**FIRE HAZARD.** An integral thermostat, if provided, is designed for temperature control service only. Because the thermostat does not fail safe, it should not be used for temperature limiting duty. Wiring to this device is the responsibility of the user.

### ⚠ WARNING

The system designer is responsible for the safety of this equipment and should install adequate back-up controls and safety devices with their

electric heating equipment. Where the consequences of failure could result in personal injury or property damage, back-up controls are essential.

### ⚠ WARNING

**FIRE/EXPLOSION HAZARD.** Use only Explosion Resistant Enclosures (E2, E3 or ER) in hazardous atmospheres where flammable vapors, gases, liquids or other combustible atmospheres are present as defined in the National Electrical Code (NFPA 70). Failure to comply could result in personal injury or property damage.

## INSTALLATION

### ⚠ WARNING

**ELECTRIC SHOCK HAZARD.** Disconnect all power before installing or servicing heater. Failure to do so could result in personal injury or property damage. Heater must be installed by a qualified person in accordance with the National Electrical Code, NFPA 70.

- Before installing, check your Over-The-Side heater for any damage that may have occurred during shipment. Also, check to ensure that the line voltage is the same as that stamped on the nameplate.
- Do not bend heating elements. If bending is necessary, consult factory.
- IMPORTANT:** Mount the heater in the tank so that the liquid level will always be above the effective heated portion of the heater. If the heater is not properly submerged, it will overheat and damage the heating elements and create a possible fire hazard due to excessive sheath temperatures. See "Warning" under "Installation" section. (see Figure 3).
- Heater must be supported from tank bottom. Heater must not be operated in sludge. Sludge legs can be provided. Assemble as shown in Figure 3.
- Where work will pass over or near equipment, additional protection, such as a metal guard, may be needed.
- In the electroplating operation the heaters are not, under any circumstance, to be placed between the electrodes and the work.

- When melting solids by direct immersion, a surface vent should be provided to allow gases to escape. Operate the heater on half voltage until melted material completely covers the heater area.
- A drip loop is recommended to minimize passage of moisture along wiring into terminal enclosure and connections.

### ⚠ WARNING

**FIRE HAZARD.** Since heaters are capable of developing high temperatures, extreme care should be taken to:

- Use explosion-resistant terminal enclosures in hazardous locations. Consult Chromalox for selection of explosion-resistant terminal enclosures for hazardous locations.
- Avoid contact between heater and combustible materials.
- Keep combustible materials far enough away to be free of the effects of high temperatures.

### ⚠ CAUTION

**FREEZE HAZARD.** Some Over-The-Side heaters are equipped with a thermowell for process control or over-temperature control. Do not allow moisture to accumulate in thermowell. Freezing temperatures can cause damage that may result in the heated medium leaking into terminal enclosure.

## INSTALLATION (cont'd.)

9. To prevent moisture accumulation in cryogenic applications or when heater is exposed to freezing temperatures:
  - A. Slope conduit away from enclosure (drip loop).
  - B. Seal all conduit openings to moisture/explosion resistant terminal enclosure.
  - C. Insulate terminal enclosure.

### ⚠ WARNING

**FIRE OR SHOCK HAZARD. Moisture accumulation in the element refractory material, element over-temperature, or sheath corrosion can cause ground fault to the element sheath, generating arcing and molten metal. Install Ground Fault Circuit-Interrupter (GFCI) to prevent personal injury or Equipment Ground Fault Protection to prevent property damage.**

10. Heaters with floor flange:
  - A. Remove electrical enclosure.
  - B. Mount heater to tank or manhole cover.
  - C. Install electrical enclosure.

### ⚠ CAUTION

**Fittings into electrical enclosure must be properly sealed to prevent contamination of electrical contacts from vapors.**

### ⚠ WARNING

**FIRE OR EXPLOSION HAZARD. If the heater is not properly submerged, the heating elements will over-heat and could result in a fire or damaged equipment.**

**NOTE: If heating in closed vessels, controls and backup controls must be used to prevent buildup of temperature and/or pressure. Maximum pressure rating is 50 PSI.**

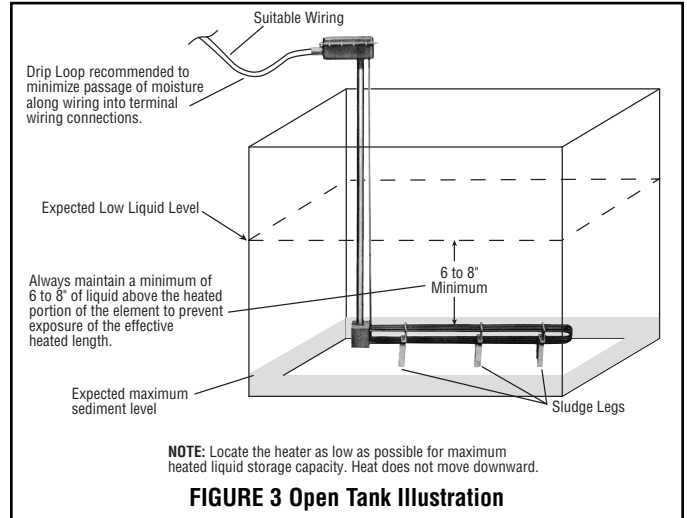

**FIGURE 3 Open Tank Illustration**

## WIRING

### ⚠ WARNING

**ELECTRIC SHOCK HAZARD. Any installation involving electric heaters must be performed by a qualified person and must be effectively grounded in accordance with the National Electrical Code to eliminate shock hazard.**

1. Electric wiring to heater must be installed in accordance with the National Electrical Code and with local codes by a qualified person. CAUTION: Use copper conductors only.
2. When element wattages are not equal, heaters must not be connected in series.
3. Electrical wiring to heater should be contained in rigid conduit or in sealed flexible conduit to keep corrosive vapors and liquids out of the terminal enclosure. If high humidity is encountered, the conduit should slope away from the heater.
4. If flexible cord is employed, a watertight connector should be used for entry of the cord into the terminal enclosure. Outdoor applications require liquid-tight conduit and connectors.
5. Bring the power line wires through the opening in the terminal enclosure.

6. Heaters are prewired and tagged for easy installation of electrical wiring to the heater. Tagging of the individual circuits of Chromalox Industrial Over-The-Side Immersion heaters is shown in the following tabulations. Refers to Type TLC, TLO, TLS, TLI, KTLC, KTLO, KTLS, KTLI, KBLC, KBLI, BLCK, and BLCS Series heaters.
7. Make sure heater, is grounded by attaching ground conductor, traceable back to service entrance, to the ground terminal located inside the terminal enclosure. If heater is used in an electroplating tank, the heater should be grounded externally to the tank wall to minimize stray plating currents in heater sheath that may cause sheath corrosion.
8. Check for loose terminal connections and tighten if necessary. Made to order items are prewired and tagged at the factory. Wiring of made to order items may differ from those shown in the tabulations. **Carefully check voltage and phase on the heater name-plate and select either the appropriate wiring shown above or check for the appropriate wiring diagram in the heater terminal enclosure.** For reference purposes, some typical wiring diagrams are shown in the following figures.

## WIRING DIAGRAMS – TLC, TLO, TLS, TLI

Model	120V	120V	240V	240V	480V	480V	480V	Model	120V	120V	240V	240V	480V	480V	480V
	1Ø Fig.	3ØΔ Fig.	1Ø Fig.	3ØΔ Fig.	1Ø Fig.	3ØΔ Fig.	3ØY Fig.		1Ø Fig.	3ØΔ Fig.	1Ø Fig.	3ØΔ Fig.	1Ø Fig.	3ØΔ Fig.	3ØY Fig.
TLC, TLI and TLS 210	—	—	1	—	1	—	—	TLO 310	—	—	3	4	3	4	—
TLC, TLI and TLS 212	—	—	1	—	1	—	—	TLC, TLI and TLS 312	—	—	3	4	3	4	—
TLC, TLI, TLO and TLS 220	1	—	1	—	2	—	—	TLC, TLI and TLS 315	—	—	3	4	3	4	—
TLO 230	1	—	1	—	1	—	—	TLC, TLI and TLS 318	—	—	3	4	3	4	—
TLC, TLI, TLO and TLS 240	1	—	1	—	1	—	—	TLC, TLI, TLO and TLS 330	3	4	3	4	5	4	6
TLO 250	1	—	1	—	1	—	—	TLO 345	3	4	3	4	3	4	—
TLC, TLI, TLO and TLS 260	1	—	1	—	1	—	—	TLC, TLI, TLO and TLS 360	3	4	3	4	3	4	—
TLO 270	—	—	1	—	1	—	—	TLO 375	3	4	3	4	3	4	—
TLC, TLI and TLS 280	—	—	1	—	1	—	—	TLC, TLI, TLO and TLS 390	3	4	3	4	3	4	—

**Note:** Use wire size and type specified by NEC.  
 480V heaters require 600V wire per NEC.  
 480V heaters require a contactor.  
 Contactor and wiring supplied by customer.

## WIRING DIAGRAMS – KTLC, KTLO, KTLS, KTLI

Model	120V 1 $\phi$ Fig.	120V 3 $\phi$ $\Delta$ Fig.	240V 1 $\phi$ Fig.	240V 3 $\phi$ $\Delta$ Fig.	480V 1 $\phi$ Fig.	480V 3 $\phi$ $\Delta$ Fig.	480V 3 $\phi$ Y Fig.	Model	120V 1 $\phi$ Fig.	120V 3 $\phi$ $\Delta$ Fig.	240V 1 $\phi$ Fig.	240V 3 $\phi$ $\Delta$ Fig.	480V 1 $\phi$ Fig.	480V 3 $\phi$ $\Delta$ Fig.	480V 3 $\phi$ Y Fig.
KTLC, KTLI and KTLS 210	—	—	1	—	1	—	—	KTLO 310	—	—	3	4	3	4	—
KTLC, KTLI and KTLS 212	—	—	1	—	1	—	—	KTLC, KTLI and KTLS 312	—	—	3	4	3	4	—
KTLC, KTLI, KTLO and KTLS 220	1	—	1	—	2	—	—	KTLC, KTLI and KTLS 315	—	—	3	4	3	4	—
KTLO 230	1	—	1	—	1	—	—	KTLC, KTLI and KTLS 318	—	—	3	4	3	4	—
KTLC, KTLI, KTLO and KTLS 240	1	—	1	—	1	—	—	KTLC, KTLI, KTLO and KTLS 330	3	4	3	4	5	4	6
KTLO 250	1	—	1	—	1	—	—	KTLO 345	3	4	3	4	3	4	—
KTLC, KTLI, KTLO and KTLS 260	1	—	1	—	1	—	—	KTLC, KTLI, KTLO and KTLS 360	3	4	3	4	3	4	—
KTLO 270	—	—	1	—	1	—	—	KTLO 375	3	4	3	4	3	4	—
KTLC, KTLI and KTLS 280	—	—	1	—	1	—	—	KTLC, KTLI, KTLO and KTLS 390	3	4	3	4	3	4	—

**Note:** Use wire size and type specified by NEC.  
480V heaters require 600V wire per NEC.  
480V heaters require a contactor.  
Contactor and wiring supplied by customer.

## WIRING DIAGRAMS – BLCK, BLCS

Model	120V 1 $\phi$ Fig.	120V 3 $\phi$ $\Delta$ Fig.	240V 1 $\phi$ Fig.	240V 3 $\phi$ $\Delta$ Fig.	480V 1 $\phi$ Fig.	480V 3 $\phi$ $\Delta$ Fig.	480V 3 $\phi$ Y Fig.	Model	120V 1 $\phi$ Fig.	120V 3 $\phi$ $\Delta$ Fig.	240V 1 $\phi$ Fig.	240V 3 $\phi$ $\Delta$ Fig.	480V 1 $\phi$ Fig.	480V 3 $\phi$ $\Delta$ Fig.	480V 3 $\phi$ Y Fig.
BLCK	—	—	1	4	1	4	—	BLCS	—	—	7	8	7	8	—

**Note:** Use wire size and type specified by NEC.  
480V heaters require 600V wire per NEC.  
480V heaters require a contactor.  
Contactor and wiring supplied by customer.

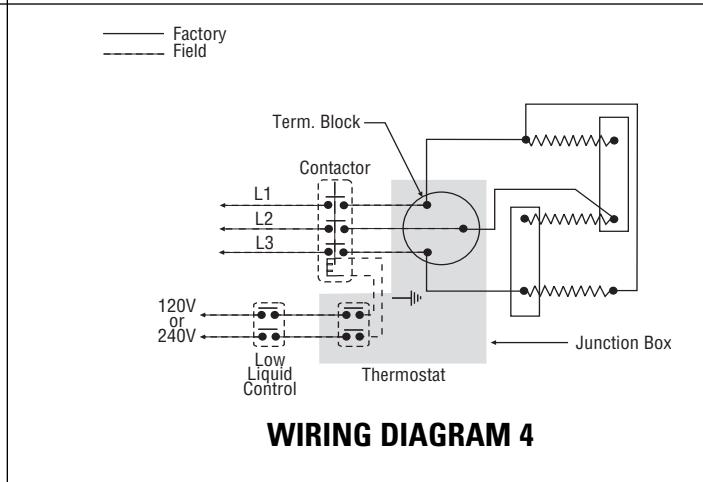
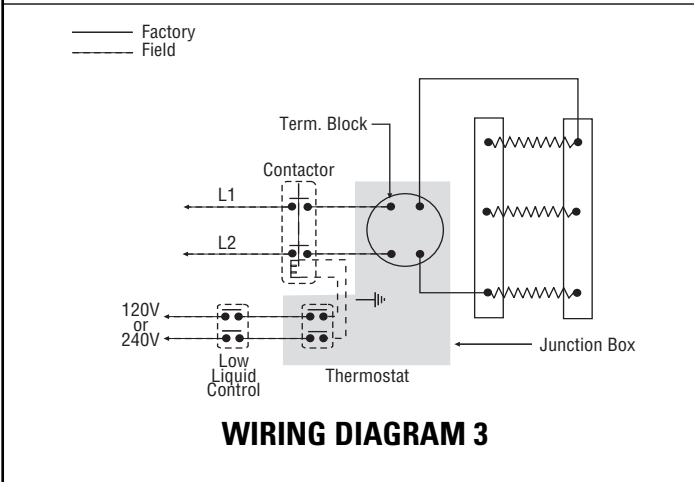
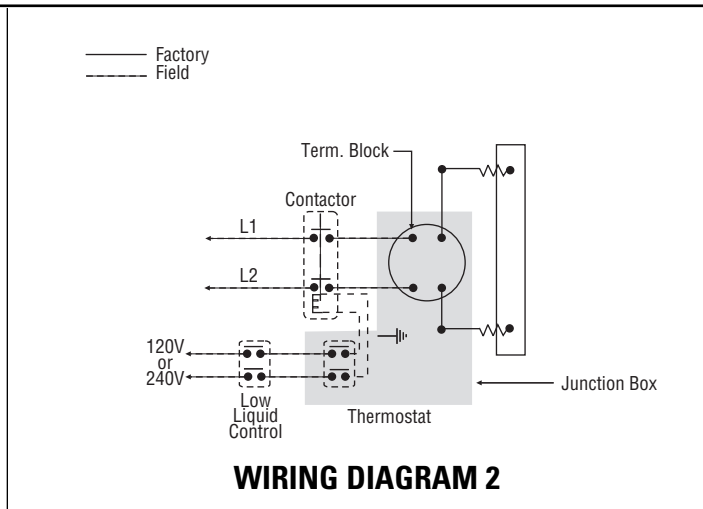
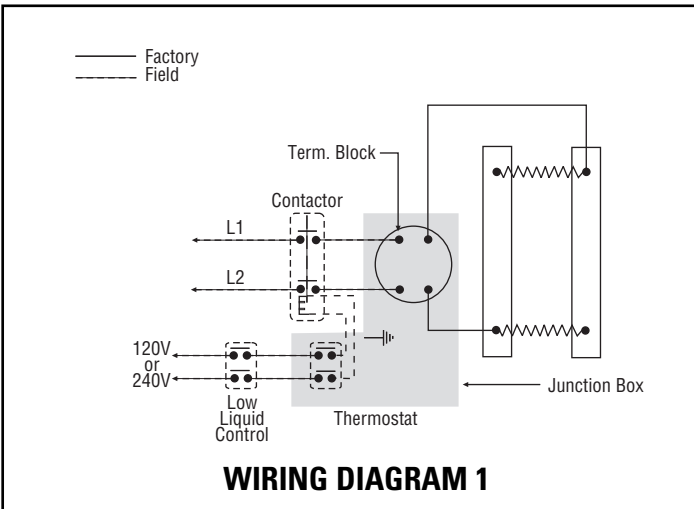

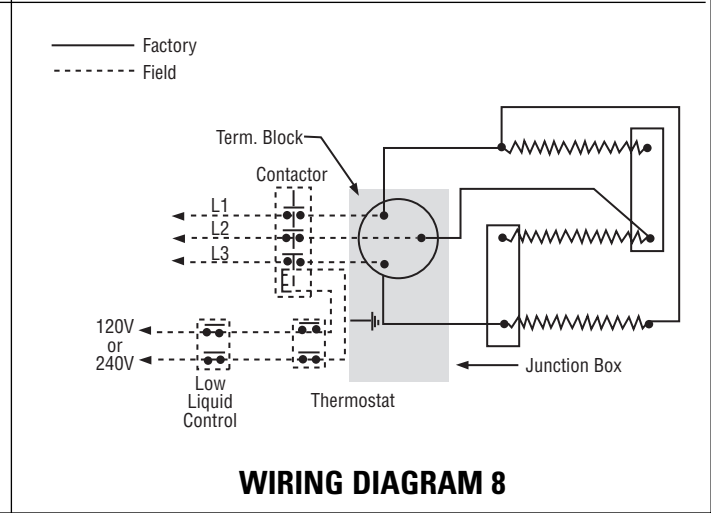
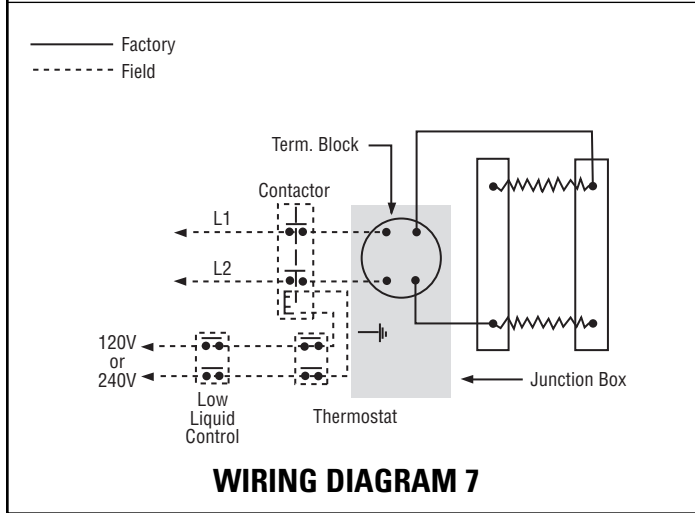
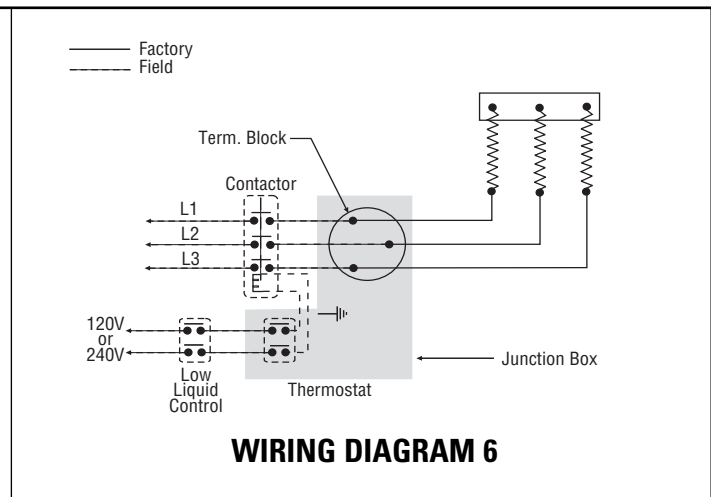
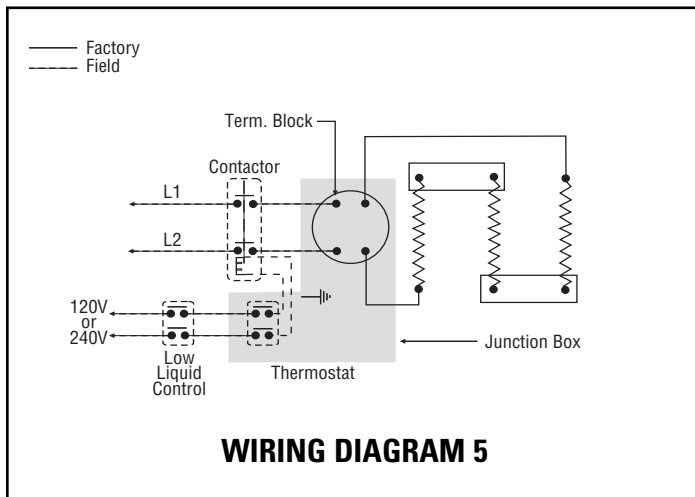

## OPERATION

1. Do not operate heater at voltages in excess of that stamped on the heater since excess voltage will shorten heater life.
2. Always maintain a minimum of 6 to 8" of liquid above the heated portion of the element to prevent exposure of the effective heated length. If the heater is not properly submerged, it will overheat and shorten heater life. **DO NOT OPERATE HEATER IF DRY.**
3. Keep heating elements above sediment deposits.
4. **Low Megohm Condition** — The refractory material used in electric heaters may absorb moisture during transit, storage or when subject to humid environments that will reduce the cold insulation resistance (low megohm). Low megohm may result in a high leakage current to ground and nuisance trips of ground fault protection equipment. Normally, the megohm value increases after heat-up. Typical insulation values are 5 megohm or greater on complete

assemblies or 20 megohm on individual unsealed elements. It is recommended that heaters with 1 megohm or less be dried out before applying full power. If dried properly, low megohm will not effect heater life or efficiency.

To correct a low megohm condition, remove terminal enclosure cover, gaskets, and terminal hardware. Bake heaters in an oven at 300 to 500°F for several hours or preferably overnight.

An alternate procedure is to cycle the heater in 10 to 15 minute periods at low voltage until megohm values are normal. Sheath temperatures should not exceed 350°F.

**NOTE:** Low megohm on heating elements with epoxy or hermetic seals cannot be serviced in the field. Typical resistance values when sealed are 200 megohm or greater. Contact Chromalox service center at number listed.

## MAINTENANCE

### **⚠ WARNING**

**ELECTRIC SHOCK HAZARD. Disconnect all power before installing or servicing heater. Failure to do so could result in personal injury or property damage.**

1. Heaters should be checked periodically for coatings and corrosion and cleaned if necessary.
2. The tank should be checked regularly for sediment around the heater as sediment can act as an insulator and shorten heater life.  
**Note:** Applies to all items, not just #2.

**Note:** User is responsible for maintenance schedule based on their knowledge of the heated medium and operating conditions.

3. Remove any accumulated sludge deposits from heater and from tank.
4. Check for loose terminal connections.
5. If corrosion is indicated in the terminal enclosure, check terminal enclosure gasket and replace if necessary. Check conduit layout to correct conditions that allow corrosion to enter the terminal enclosure.
6. Clean terminal ends of all contamination.

## RENEWAL PARTS

1. Thermostat Kit (order by PCN):
  - A. 0-100°F .....PCN 277835
  - B. 60-250°F .....PCN 277819
2. Thermostat Knob:
  - A. 0-100°F .....169-019605-002
  - B. 60-250°F .....169-019604-001
  - C. 200-550°F .....169-019604-002
3. Sludge Legs:
  - A. TLC, KTLC Series .....176-114713-001
  - B. TLI, KTLI Series .....176-114713-001
  - C. TLO, KTLO Series .....176-114713-002
  - D. TLS, KTLS Series .....176-114713-003

- Gasket .....132-012603-004
  - Cover .....080-012602-001
  - 4 Post Terminal Block .....303-001843-001
  - 3 Post Terminal Block .....303-006621-003
  - Thermostat Mounting Bracket .....027-072456-001
4. Thermostat
    - A. 0-100°F (84" Capillary) .....300-048518-005
    - B. 60-250°F (84" Capillary) .....300-048518-002
    - C. 200-550°F (84" Capillary) .....300-048518-004
    - D. 0-100°F (144" Capillary) .....300-048518-019
    - E. 60-250°F (180" Capillary) .....300-048518-022
    - F. 200-550°F (180" Capillary) .....300-048518-023

### WARRANTY AND LIMITATION OF REMEDY AND LIABILITY

Chromalox warrants only that the Products and parts manufactured by Chromalox, when shipped, and the work performed by Chromalox when performed, will meet all applicable specification and other specific product and work requirements (including those of performance), if any, and will be free from defects in material and workmanship under normal conditions of use. All claims for defective or nonconforming (both hereinafter called defective) Products, parts or work under this warranty must be made in writing immediately upon discovery, and in any event, within one (1) year from delivery, provided, however all claims for defective Products and parts must be made in writing no later than eighteen (18) months after shipment by Chromalox. Defective and nonconforming items must be held for Chromalox's inspections and returned to the original f.o.b. point upon request. THE FOREGOING IS EXPRESSLY IN LIEU OF ALL OTHER WARRANTIES WHATSOEVER, EXPRESS, IMPLIED AND STATUTORY, INCLUDING, WITHOUT LIMITATION, THE IMPLIED WARRANTIES OF MERCHANTABILITY AND FITNESS FOR A PARTICULAR PURPOSE.

Notwithstanding the provisions of this WARRANTY AND LIMITATION Clause, it is specifically understood that Products and parts not manufactured and work not performed by Chromalox are warranted only to the extent and in the manner that the same are warranted to Chromalox by Chromalox's vendors, and then only to the extent that Chromalox is reasonably able to enforce such warranty, it being understood Chromalox shall have no obligation to initiate litigation unless Buyer undertakes to pay all cost and expenses therefor, including but not limited to attorney's fees, and indemnifies Chromalox against any liability to Chromalox's

vendors arising out of such litigation.

Upon Buyer's submission of a claim as provided above and its substantiation, Chromalox shall at its option either (i) repair or replace its Products, parts or work at the original f.o.b. point of delivery or (ii) refund an equitable portion of the purchase price.

THE FOREGOING IS CHROMALOX'S ONLY OBLIGATION AND BUYER'S EXCLUSIVE REMEDY FOR BREACH OF WARRANTY, AND IS BUYER'S EXCLUSIVE REMEDY AGAINST CHROMALOX FOR ALL CLAIMS ARISING HEREUNDER OR RELATING HERETO WHETHER SUCH CLAIMS ARE BASED ON BREACH OF CONTRACT, TORT (INCLUDING NEGLIGENCE AND STRICT LIABILITY) OR OTHER THEORIES. BUYER'S FAILURE TO SUBMIT A CLAIM AS PROVIDED ABOVE SHALL SPECIFICALLY WAIVE ALL CLAIMS FOR DAMAGES OR OTHER RELIEF, INCLUDING BUT NOT LIMITED TO CLAIMS BASED ON LATENT DEFECTS. IN NO EVENT SHALL BUYER BE ENTITLED TO INCIDENTAL OR CONSEQUENTIAL DAMAGES AND BUYER SHALL HOLD CHROMALOX HARMLESS THEREFROM. ANY ACTION BY BUYER ARISING HEREUNDER OR RELATING HERETO, WHETHER BASED ON BREACH OF CONTRACT, TORT (INCLUDING NEGLIGENCE AND STRICT LIABILITY) OR OTHER THEORIES, MUST BE COMMENCED WITHIN ONE (1) YEAR AFTER THE DATE OF SHIPMENT OR IT SHALL BE BARRED.

W2008M

**Chromalox**<sup>®</sup>  
**PRECISION HEAT AND CONTROL**

2150 N. RULON WHITE BLVD., OGDEN, UT 84404  
Phone: 1-800-368-2493      www.chromalox.com