

EDS Factory Sealed and EFS Tumbler Switches: Explosionproof, Dust-Ignitionproof

UNILETS® for Use with Threaded Metal Conduit.

Applications

- Designed to prevent arcing of enclosed switches in ignitable atmospheres during connect and disconnect operation of lighting and light power loads.
- For use in classified areas where ignitable vapors, gases or highly combustible dusts are present.
- For installation in chemical and petrochemical plants, refineries, and other process industries.

Features:

All Tumbler Switches

- EDS and EFS enclosures have external mounting lugs for ease of mounting.
- Smooth, rounded integral bushing in each hub protects conductor insulation.
- Enclosures furnished with internal ground screw.
- 20-ampere and 30-ampere units available for use with 120-277 Volt A.C.

Features:

EDS Factory Sealed Tumbler Switches

- Factory sealed switches are designed to a U.L. standard so that any arcing devices are within a chamber which *contains* any explosions. EDS tumbler switch devices are approved for installation without additional external sealing fittings.
- 1/2" and 3/4" single gang units suitable for Class I, Group B, in addition to Class I, Groups C and D; Class II, Groups E, F and G; and Class III.
- Switch is enclosed in separate sealing chamber.
- Smooth double-face, accurately ground surfaces on sealing chamber flange mate with cover and body to provide positive flame-tight construction.
- Sealing chamber has prewired factory sealed pigtail leads to switch.
- Corrosion-resistant, strong stainless steel hex-head cap screws attach cover/body/sealing chamber assembly for approved flame-tight construction.
- Threaded stainless steel operating handle provides positive corrosion-resistant operation.
- Choice of Front-Operating or Side Rocker Arm Handle—each may be locked in ON or OFF position.

EDS Factory Sealed Tumbler Switches

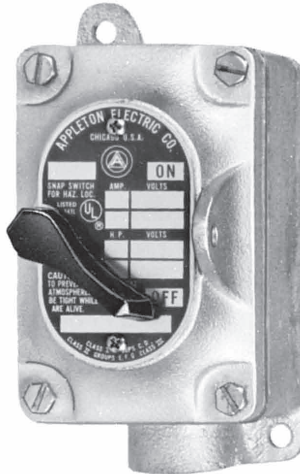

Front Operated

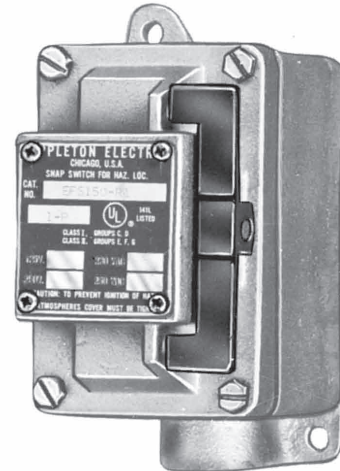

Rocker Arm Operated

EFS Non-Sealed Tumbler Switches

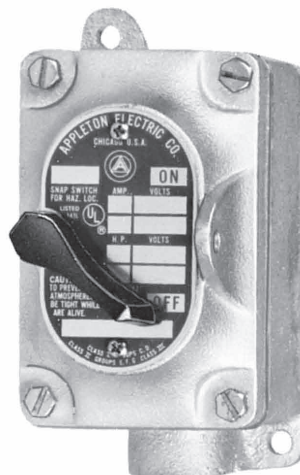

Front Operated

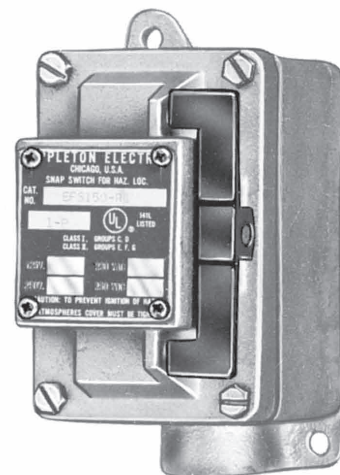

Rocker Arm Operated

EDS Factory Sealed and EFS Tumbler Switches: Explosionproof, Dust-Ignitionproof

UNILETS® for Use with Threaded Metal Conduit.

Features:

EFS Non-Sealed Tumbler Switches

- Smooth ground mating surfaces assure flame-tight joint between cover and mounting enclosure.
- Stainless steel hex-head cap screws for attaching cover to mounting enclosure.
- Choice of Front-Operating or Side Rocker Arm Handle—each may be locked in ON or OFF position.
- Each handle has close-tolerance threaded stainless steel shaft to meet Explosionproof requirements.
- Enclosures furnished with internal ground screw.

Standard Materials

- *EDS tumbler switches*: malleable iron body and cover with aluminum sealing chamber. Handle is nylon 6/6.
- *EFS tumbler switches*: malleable iron body and cover.

Standard Finishes

- *EDS and EFS tumbler switches*: triple-coat—(1) zinc electroplate, (2) dichromate, and (3) epoxy powder coat.

Compliances:

- UL Standard 894.
- Class I, Div. 1 and 2; Class II, Div. 1 and 2. See listing pages for specific groups. Conduit seals are required in Class I areas unless unit is factory sealed.
- Appleton malleable iron products conform to ASTM A47-77, Grade 32510, which has the following properties; tensile strength, 50,000 psi; yield, 32,000 psi; and elongation, 10%.
- Appleton aluminum products are produced from a high strength copper-free (4/10 of 1% max.) alloy.

Product Cross Reference:

- For classified-location push button, pilot light and selector switch control stations, see Catalog Section M.

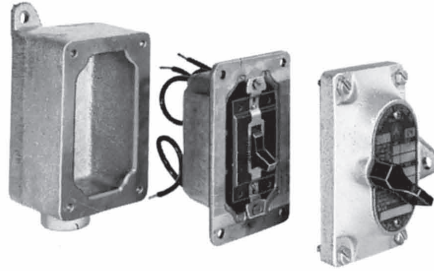

EDS factory sealed tumbler switch—shows separate sealing chamber and switch construction.

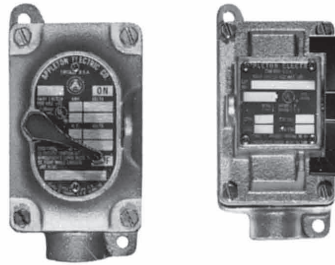

EDS and EFS choice of handles—front-operated or rocker arm handle.

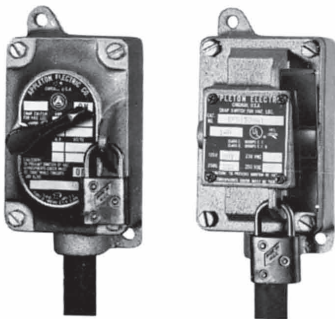

EDS and EFS handles may be locked in ON or OFF position.

Ordering Information for “Custom” EDS and EFS Units

Devices, covers and bodies may be ordered separately so that a *different* EDS Chamber/Switch Assembly or EFS Switch may be used in *each* gang.

Order components separately as follows: (1) select body catalog number, (2) select cover catalog number, and (3) select switch or switch assembly catalog number (1-pole, 2-pole, 3-way or 4-way available in listings).

How to Order Hub Arrangements

Simply send sketch indicating sizes and locations for brazed hubs on body or bodies selected from catalog listings. Orient sketch so that cover opening faces front and mounting lugs face upward and downward (box wall opposite cover should be referred to as the *back* of box).

See Catalog Section M, Page 23, for additional ordering information.

Bodies and Hubs Available



- EDS and EFS tumbler switches may be ordered in single thru five gang deep malleable iron blank bodies with brazed hubs as specified at any location.
- EDS and EFS tumbler switches may be ordered with tandem malleable iron boxes with *additional* brazed hubs as specified.
- Standard EDS and EFS malleable iron single and two gang tumbler switches may be ordered with *additional* brazed hubs as specified.
- EDS and EFS single and two gang tumbler switches may be ordered with *aluminum* boxes with *additional* brazed hubs as specified.

N-4

Class I, Div. 1 and 2,
Groups B,C,D
Class II, Div. 1 and 2,
Groups E,F,G
Class III
NEMA 7 BCD,9EFG

EDS Factory Sealed Tumbler Switches: Front Operated; Explosionproof, Dust-Ignitionproof

Malleable Iron Body and Cover.
UNILETS® for Use with Threaded Metal Conduit.
Furnished with Internal Ground Screw.

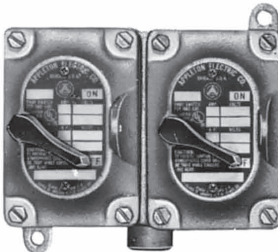
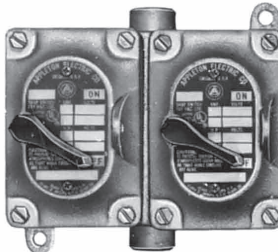
	Hub Size, Inches	Switch	Catalog Number†	
			Dead-End	Feed-Thru
Single Gang				
20-Ampere—120-277 Volt A.C.*				
	1/2	1-Pole	EDS150-F1	EDSC150-F1
	1/2	2-Pole	EDS150-F2	EDSC150-F2
	1/2	3-Way	EDS150-F3W	EDSC150-F3W
	1/2	4-Way	EDS150-F4W	EDSC150-F4W
	3/4	1-Pole	EDS175-F1	EDSC175-F1
	3/4	2-Pole	EDS175-F2	EDSC175-F2
	3/4	3-Way	EDS175-F3W	EDSC175F3W
	3/4	4-Way	EDS175-F4W	EDSC175F4W
Dead-End	1	1-Pole	EDS110-F1	EDSC110-F1
	1	2-Pole	EDS110-F2	EDSC110-F2
	1	3-Way	EDS110-F3W	EDSC110-F3W
	1	4-Way	EDS110-F4W	EDSC110-F4W
30-Ampere—120-277 Volt A.C.**				
	3/4	1-Pole	EDS175-F13	EDSC175-F13
	3/4	2-Pole	EDS175-F23	EDSC175-F23
	3/4	3-Way	EDS175-F3W3	EDSC175-F3W3
Feed-Thru	1	1-Pole	EDS110-F13	EDSC110-F13
	1	2-Pole	EDS110-F23	EDSC110-F23
	1	3-Way	EDS110-F3W3	EDSC110-F3W3
Two Gang				
20-Ampere—120-277 Volt A.C.*				
	1/2	1-Pole	EDS250-F1	EDSC250-F1
	1/2	2-Pole	-----	EDSC250-F2
	1/2	3-Way	-----	EDSC250-F3W
	1/2	4-Way	-----	EDSC250-F4W
	3/4	1-Pole	EDS275-F1	EDSC275-F1
	3/4	2-Pole	-----	EDSC275-F2
	3/4	3-Way	EDS275-F3W	EDSC275F3W
	3/4	4-Way	-----	EDSC275F4W
Dead-End	1	1-Pole	EDS210-F1	EDSC210-F1
	1	2-Pole	EDS210-F2	EDSC210-F2
	1	3-Way	EDS210-F3W	EDSC210-F3W
	1	4-Way	EDS210-F4W	EDSC210-F4W
	1	1-Pole	EDS210-F1	EDSC210-F1
	1	2-Pole	EDS210-F2	EDSC210-F2
	1	3-Way	EDS210-F3W	EDSC210-F3W
	1	4-Way	EDS210-F4W	EDSC210-F4W
Feed-Thru				

† For Aluminum Backbox and Cover, add Suffix - A.



* 20 Amp—1 HP at 120 Volt A.C. and 2 HP at 240 Volt A.C. **30 Amp—2 HP at 120 Volt A.C. or 240 Volt A.C.

‡ Shaded area indicates items suitable for Class I, Group B, as well as Class I, Groups C and D; Class II, Groups E,F,G; and Class III.

Class I, Div. 1 and 2,
Groups B,C,D
Class II, Div. 1 and 2,
Groups E,F,G
Class III
NEMA 7 B CD,9EFG

EDS Factory Sealed Tumbler Switches: Rocker Arm Operated; Explosionproof, Dust-Ignitionproof

Malleable Iron Body and Cover.
UNILETS® for Use with Threaded Metal Conduit.
Furnished with Internal Ground Screw.

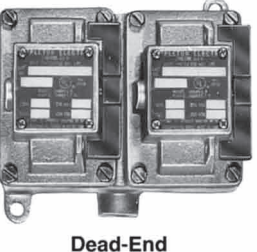
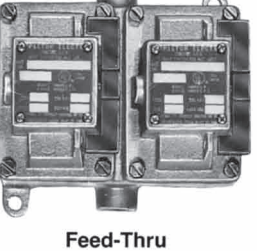
	Hub Size, Inches	Switch	Catalog Number	
			Dead-End	Feed-Thru
Single Gang				
20-Ampere—120-277 Volt A.C.*				
 Dead-End	1/2	1-Pole	EDS150-R1	EDSC150-R1
	1/2	2-Pole	EDS150-R2	EDSC150-R2
	1/2	3-Way	EDS150-R3W	EDSC150-R3W
	1/2	4-Way	EDS150-R4W	EDSC150-R4W
	3/4	1-Pole	EDS175-R1	EDSC175-R1
	3/4	2-Pole	EDS175-R2	EDSC175-R2
	3/4	3-Way	EDS175-R3W	EDSC175-R3W
	3/4	4-Way	EDS175-R4W	EDSC175-R4W
 Feed-Thru	1	1-Pole	EDS110-R1	EDSC110-R1
	1	2-Pole	EDS110-R2	EDSC110-R2
	1	3-Way	EDS110-R3W	EDSC110-R3W
	1	4-Way	EDS110-R4W	EDSC110-R4W
30-Ampere—120-277 Volt A.C.**				
 Feed-Thru	3/4	1-Pole	EDS175-R13	EDSC175-R13
	3/4	2-Pole	EDS175-R23	EDSC175-R23
	3/4	3-Way	EDS175-R3W3	EDSC175-R3W3
	1	1-Pole	EDS110-R13	EDSC110-R13
	1	2-Pole	EDS110-R23	EDSC110-R23
	1	3-Way	EDS110-R3W3	EDSC110-R3W3
Two Gang				
20-Ampere—120-277 Volt A.C.*				
 Dead-End	1/2	1-Pole	EDS250-R1	EDSC250-R1
	1/2	2-Pole	-----	EDSC250-R2
	1/2	3-Way	-----	EDSC250-R3W
	1/2	4-Way	-----	EDSC250-R4W
 Feed-Thru	3/4	1-Pole	EDS275-R1	EDSC275-R1
	3/4	2-Pole	-----	EDSC275-R2
	3/4	3-Way	EDS275-R3W	EDSC275-R3W
	3/4	4-Way	-----	EDSC275-R4W
	1	1-Pole	EDS210-R1	EDSC210-R1
	1	2-Pole	EDS210-R2	EDSC210-R2
	1	3-Way	EDS210-R3W	EDSC210-R3W
	1	4-Way	EDS210-R4W	EDSC210-R4W

*20 Amp—1 HP at 120 Volt A.C. and 2 HP at 240 Volt A.C. **30 Amp—2 HP at 120 Volt A.C. or 240 Volt A.C.



◊ Shaded area indicates items suitable for Class I, Group B, as well as Class I, Groups C and D; Class II, Groups E,F,G; and Class III.

N-6

Class I, Div. 1 and 2,
Groups C,D
Class II, Div. 1 and 2,
Groups E,F,G
Class III
NEMA 7CD,9EFG

EFS Tumbler Switches: Non-Sealed, Front Operated; Explosionproof, Dust-Ignitionproof

Malleable Iron Body and Cover.
UNILETS® for Use with Threaded Metal Conduit.
Furnished with Internal Ground Screw.

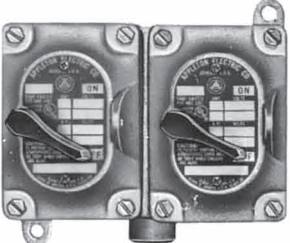
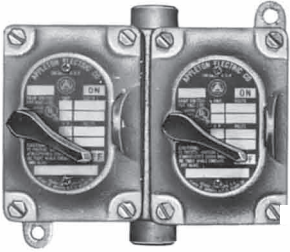
	Hub Size, Inches	Switch	Catalog Number†	
			Dead-End	Feed-Thru
 <p>Dead-End</p>	Single Gang			
	20-Ampere—120-277 Volt A.C.*			
	1/2	1-Pole	EFS150-F1	EFSC150-F1
	1/2	2-Pole	-----	EFSC150-F2
	1/2	3-Way	EFS150-F3W	EFSC150-F3W
	1/2	4-Way	EFS150-F4W	EFSC150-F4W
	3/4	1-Pole	EFS175-F1	EFSC175-F1
	3/4	2-Pole	EFS175-F2	EFSC175-F2
	3/4	3-Way	EFS175-F3W	EFSC175-F3W
	3/4	4-Way	EFS175-F4W	EFSC175-F4W
 <p>Feed-Thru</p>	30-Ampere—120-277 Volt A.C.**			
	3/4	1-Pole	EFS175-F13	EFSC175-F13
	3/4	2-Pole	EFS175-F23	EFSC175-F23
	Two Gang			
	20-Ampere—120-277 Volt A.C.*			
	 <p>Dead-End</p>	1/2	1-Pole	EFS250-F1
1/2		2-Pole	-----	EFSC250-F2
1/2		3-Way	-----	EFSC250-F3W
1/2		4-Way	-----	EFSC250-F4W
3/4		1-Pole	EFS275-F1	EFSC275-F1
3/4		2-Pole	-----	EFSC275-F2
3/4		3-Way	-----	EFSC275-F3W
3/4		4-Way	-----	EFSC275-F4W
1		2-Pole	EFS210-F2	EFSC210-F2
1		3-Way	EFS210-F3W	EFSC210-F3W
1	4-Way	EFS210-F4W	EFSC210-F4W	
 <p>Feed-Thru</p>	30-Ampere—120-277 Volt A.C.**			
	3/4	1-Pole	EFS275-F13	EFSC275-F13
	3/4	2-Pole	-----	EFSC275-F23
	1	2-Pole	EFS210-F23	EFSC210-F23



† For Aluminum Backbox and Cover, add Suffix - A.

*20 Amp—1 HP at 120 Volt A.C. and 2 HP at 240 Volt A.C. **30 Amp—2 HP at 120 Volt A.C. or 240 Volt A.C.

Class I, Div. 1 and 2,
Groups C,D
Class II, Div. 1 and 2,
Groups E,F,G
Class III
NEMA 7CD,9EFG

EFS Tumbler Switches: Non-Sealed, Rocker Arm Operated; Explosionproof, Dust-Ignitionproof

Malleable Iron Body and Cover.
UNILETS® for Use with Threaded Metal Conduit.
Furnished with Internal Ground Screw.

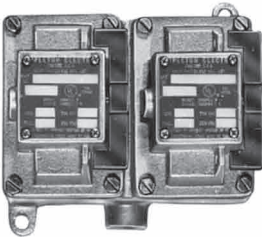
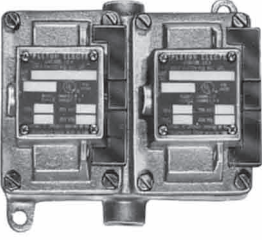
	Hub Size, Inches	Switch	Catalog Number	
			Dead-End	Feed-Thru
Single Gang				
20-Ampere—120-277 Volt A.C.*				
	1/2	1-Pole	EFS150-R1	EFSC150-R1
	1/2	2-Pole	-----	EFSC150-R2
	1/2	3-Way	EFS150-R3W	EFSC150-R3W
	1/2	4-Way	EFS150-R4W	EFSC150-R4W
	3/4	1-Pole	EFS175-R1	EFSC175-R1
	3/4	2-Pole	EFS175-R2	EFSC175-R2
	3/4	3-Way	EFS175-R3W	EFSC175-R3W
	3/4	4-Way	EFS175-R4W	EFSC175-R4W
Single Gang				
20-Ampere—120-277 Volt A.C.*				
	1/2	1-Pole	EFS250-R1	EFSC250-R1
	1/2	2-Pole	-----	EFSC250-R2
	1/2	3-Way	-----	EFSC250-R3W
	1/2	4-Way	-----	EFSC250-R4W
	3/4	1-Pole	EFS275-R1	EFSC275-R1
	3/4	2-Pole	-----	EFSC275-R2
	3/4	3-Way	-----	EFSC275-R3W
	3/4	4-Way	-----	EFSC275-R4W
Two Gang				
20-Ampere—120-277 Volt A.C.*				
	1/2	1-Pole	EFS210-R2	EFSC210-R2
	1/2	2-Pole	EFS210-R3W	EFSC210-R3W
	1/2	3-Way	EFS210-R4W	EFSC210-R4W
	1/2	4-Way	-----	-----
	3/4	1-Pole	-----	-----
	3/4	2-Pole	-----	-----
	3/4	3-Way	-----	-----
	3/4	4-Way	-----	-----
Two Gang				
20-Ampere—120-277 Volt A.C.*				
	1	2-Pole	-----	-----
	1	3-Way	-----	-----
	1	4-Way	-----	-----
	1	1-Pole	-----	-----
	1	2-Pole	-----	-----
	1	3-Way	-----	-----
	1	4-Way	-----	-----
	1	1-Pole	-----	-----

*1 HP at 120 Volt A.C.; 2 HP at 240 Volt A.C.

N-8

Class I, Div. 1 and 2
Groups C,D
Class II, Div. 1 and 2
Groups E,F,G
Class III
NEMA 7CD,9EFG

EDS/EFS Mounting Bodies, Covers and Sealing Chamber/Switch Assemblies

Furnished with Internal Ground Screw.





Hub Size, Inches	Dead-End Catalog Numbers		Feed-Thru Catalog Numbers	
	Malleable Iron	Aluminum	Malleable Iron	Aluminum
Single Gang				
1/2	EFD150-NL-Q	EFD150A-NL-Q	EFDC150-NL-Q	EFDC150A-NL-Q
3/4	EFD175-NL-Q	EFD175A-NL-Q	EFDC175-NL-Q	EFDC175A-NL-Q
1	EFD110-NL-Q	EFD110A-NL-Q	EFDC110-NL-Q	EFDC110A-NL-Q
Two Gang				
1/2	EFD250-NL-Q	EFD250A-NL-Q	EFDC250-NL-Q	EFDC250A-NL-Q
3/4	EFD275-NL-Q	EFD275A-NL-Q	EFDC275-NL-Q	EFDC275A-NL-Q
1	EFD210-NL-Q	EFD210A-NL-Q	EFDC210-NL-Q	EFDC210A-NL-Q
Tandem				
1/2	EFDT50-NL-Q	-----	EFDC250-NL-Q	-----
3/4	EFDT75-NL-Q	-----	EFDC275-NL-Q	-----
1	EFDT10-NL-Q	-----	EFDC210-NL-Q	-----

EFD Blank Bodies for Brazed Hubs

Gang	Cat. No.
1 Gang	EFD-1-NL
2 Gang	EFD-2-NL
3 Gang	EFD-3-NL
4 Gang	EFD-4-NL
5 Gang	EFD-5-NL

Construct complete catalog numbers per Cat. Sec. M, page 23. Hubs will be located in center of walls and evenly spaced unless otherwise specified. Where spacings are critical, submit sketch showing exact spacing requirements.



	Switch Type	Catalog Number	
		20 Amp 120-277 Volt AC*	30 Amp 120-277 Volt AC**
EDS Front Cover/ Chamber/Switch Assembly 	1-Pole 2-Pole 3-Way 4-Way	EDK-F21-Q† EDK-F22-Q† EDK-F23W-Q† EDK-F24W-Q	EDK-F31-Q EDK-F32-Q EDK-F33W-Q ---
EDS RockerCover/ Chamber/Switch Assembly 	1-Pole 2-Pole 3-Way 4-Way	EDK-R21-Q† EDK-R22-Q† EDK-R23W-Q† EDK-R24W-Q	EDK-R31-Q EDK-R32-Q EDK-R33W-Q ---
Switch Only 	1-Pole 2-Pole 3-Way	LAB21 LAB22 LAB23W	--- --- ---

*20A Switches 1 HP at 120 Volt A.C. and 2 HP at 240 Volt A.C. **30A Switches 2 HP at 120 Volt A.C. or 240 Volt A.C.
† Contains Factory Sealed Switch; no sealing chamber.

**Class I, Div. 1 and 2,
Groups C,D
Class II, Div. 1 and 2,
Groups E,F,G
Class III
NEMA 7CD,9EFG**

EFS Mounting Covers and Switches

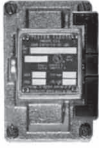
Non-Factory Sealed Covers Furnished with
Device Mounting Screws.

			Switch Type	Front Cover	Catalog Number Rocker Cover	Switch
EFS Covers and Switches						
			20-Ampere—120-277 Volt A.C.*			
			1-Pole	EFK-F12-Q	EFK-R12-Q	EFS-FR1-Q
			2-Pole	EFK-F12-Q	EFK-R12-Q	EFS-FR2-Q
			3-Way	EFK-F34W-Q	EFK-R34W-Q	EFS-FR3W-Q
			4-Way	EFK-F34W-Q	EFK-R34W-Q	EFS-FR4W-Q
30-Ampere—120-277 Volt A.C.**						
			1-Pole	EFK-F12-Q	EFK-R12-Q	EFS-FR13-Q
			2-Pole	EFK-F12-Q	EFK-R12-Q	EFS-FR23-Q
			3-Way	EFK-F34W-Q	EFK-R34W-Q	EFS-FR3W3-Q

*20A Switches 1HP at 120 Volt A.C. and 2 HP at 240 Volt A.C. **30A Switches 2 HP at 120 or 240 Volt A.C.
For Aluminum Cover add Suffix **-A**.



NPBRKT Nameplate Mounting Bracket

For use with EFDB, EFS, Contender® and N1/N2 Series Control Stations, Tumbler Switches and Manual Motor Starters.

Applications

- For mounting on EFDB, EFS, Contender and Intraground series control stations to make circuit description/identification easy.

Features

- Pre-drilled holes in bottom of bracket allow direct mounting to Appleton EFDB, EFS, Contender and intraground series control stations with existing cover bolts (Intraground series bracket is mounted using nameplate screws).
- Pre-drilled holes in middle of bracket allow mounting of customer's circuit identification nameplate; epoxy glue may also be used for mounting (phenolic nameplate not included).
- Nameplate mounting bracket is corrosion resistant stainless steel.
- Bracket eliminates costly field installation of drilling and tapping to accommodate circuit identification nameplate.
- Brackets fit side-by-side on 2, 3 and 4 gang boxes and 3 Device EFD Series.



Description	Catalog Number*
Nameplate Mounting Bracket for EFDB and EFS series	NPBRKT-EFDB
Nameplate Mounting Bracket for Contender® and 3 Device EFD Series	NPBRKT-CONT
Nameplate Mounting Bracket for N1/N2 series	NPBRKT-N1N2

* To order bracket with either series control station or manual motor starter, add suffix-NPBRKT to end of catalog number.

Dimensions (In Inches):

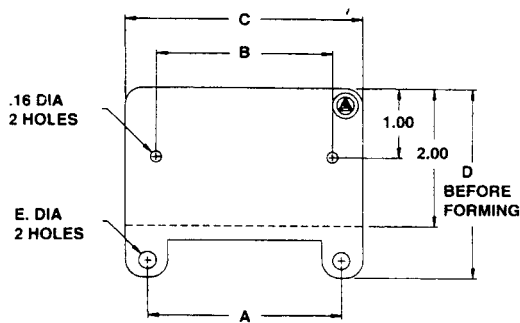

Catalog No.	A	B	C	D	E
NPBRKT-CONT	2.75	2.50	3.38	2.75	.25
NPBRKT-EFDB	2.38	2.50	3.00	2.75	.25
NPBRKT-N1N2	2.13	2.25	2.75	2.69	.16

Note: Mount bracket between cover screws and cover. Do not mount bracket between ground joint flame path between cover and back box.

Secure bracket under cover screws of box. Torque cover screws to 12ft - lbs.

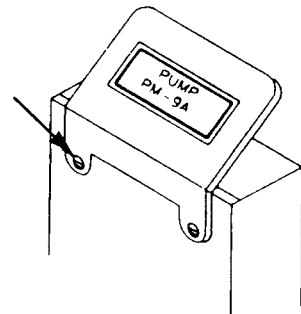

Dimensions: EDS Factory Sealed Tumbler Switches

See Catalog Section M for Tandem Body Dimensions.

EDS Front Operated Tumbler Switches

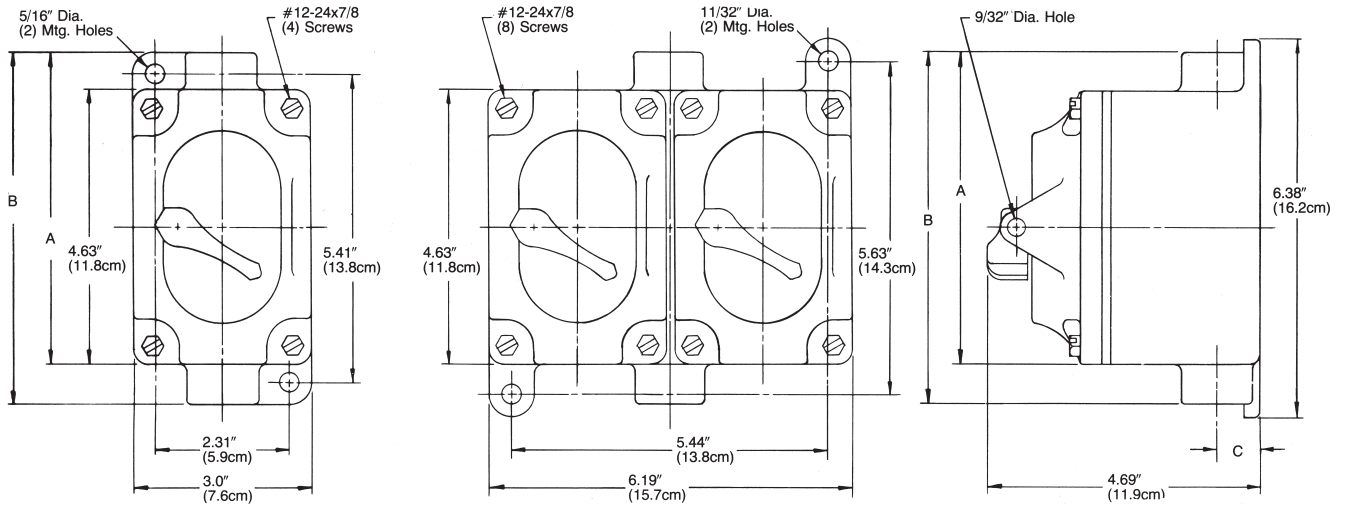

Hub Inches	Dimensions in Inches			Dimensions In Centimeters		
	A	B	C	A	B	C
1/2 & 3/4	5.38	6.13	.78	13.7	15.6	2.0
1	5.50	6.31	.94	14.0	16.0	2.4

EDS Rocker Arm Operated Tumbler Switches

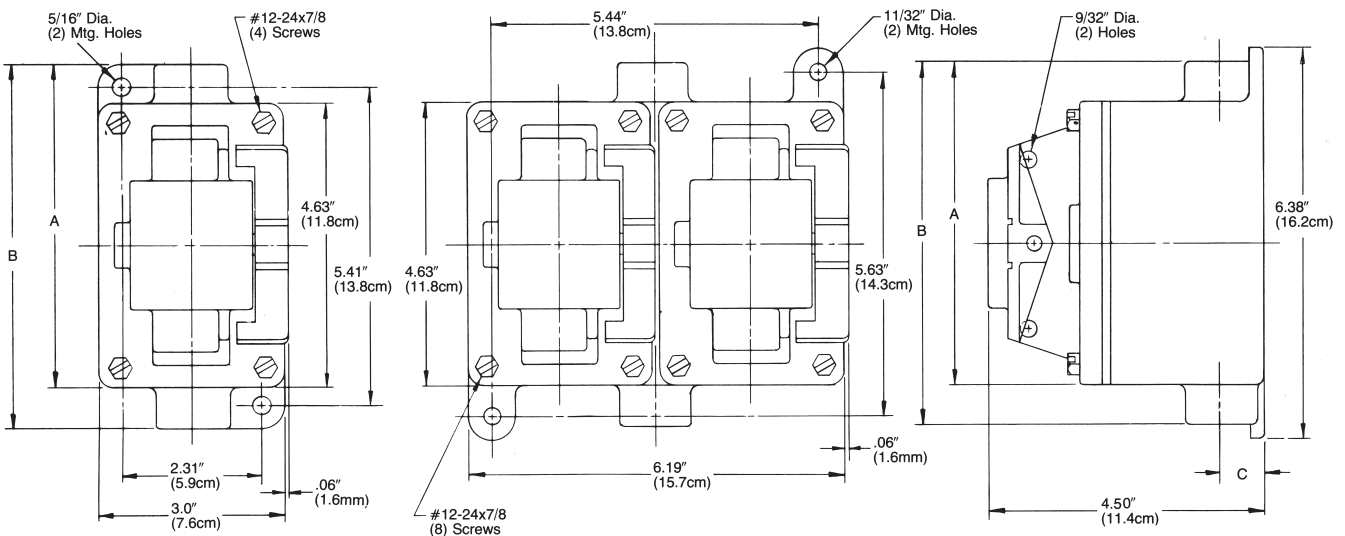

Hub Inches	Dimensions in Inches			Dimensions In Centimeters		
	A	B	C	A	B	C
1/2 & 3/4	5.38	6.13	.78	13.7	15.6	2.0
1	5.50	6.31	.94	14.0	16.0	2.4

Dimensions: EFS Tumbler Switches

See Catalog Section M for Tandem Body Dimensions.

EFS Front Operated Tumbler Switches

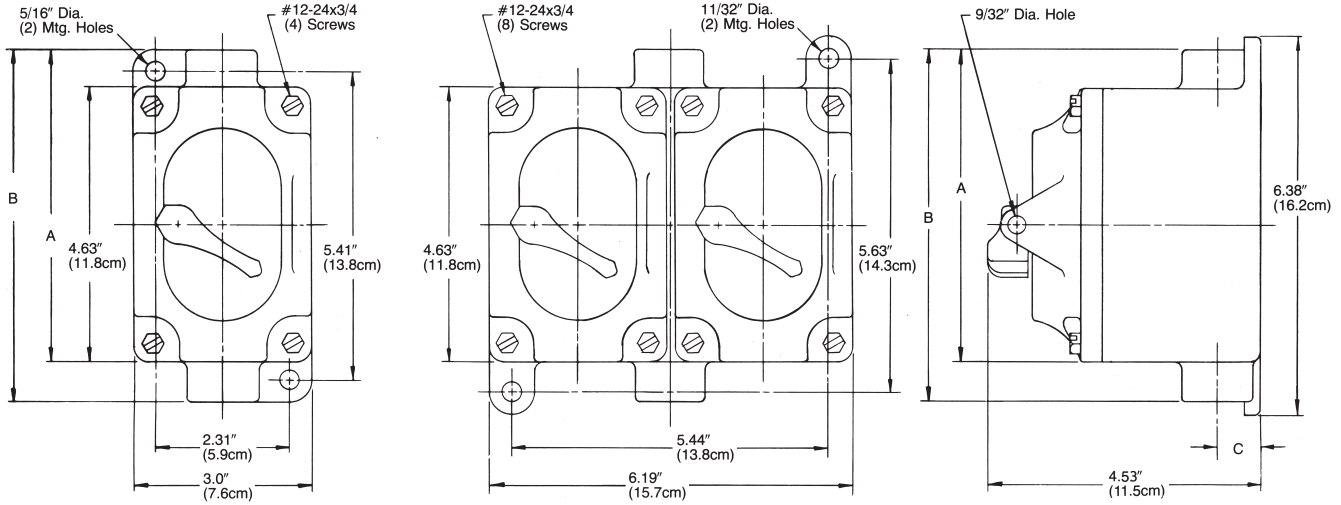

Hub Inches	Dimensions in Inches			Dimensions In Centimeters		
	A	B	C	A	B	C
1/2 & 3/4	5.38	6.13	.78	13.7	15.6	2.0
1	5.50	6.31	.94	14.0	16.0	2.4

EFS Rocker Arm Operated Tumbler Switches

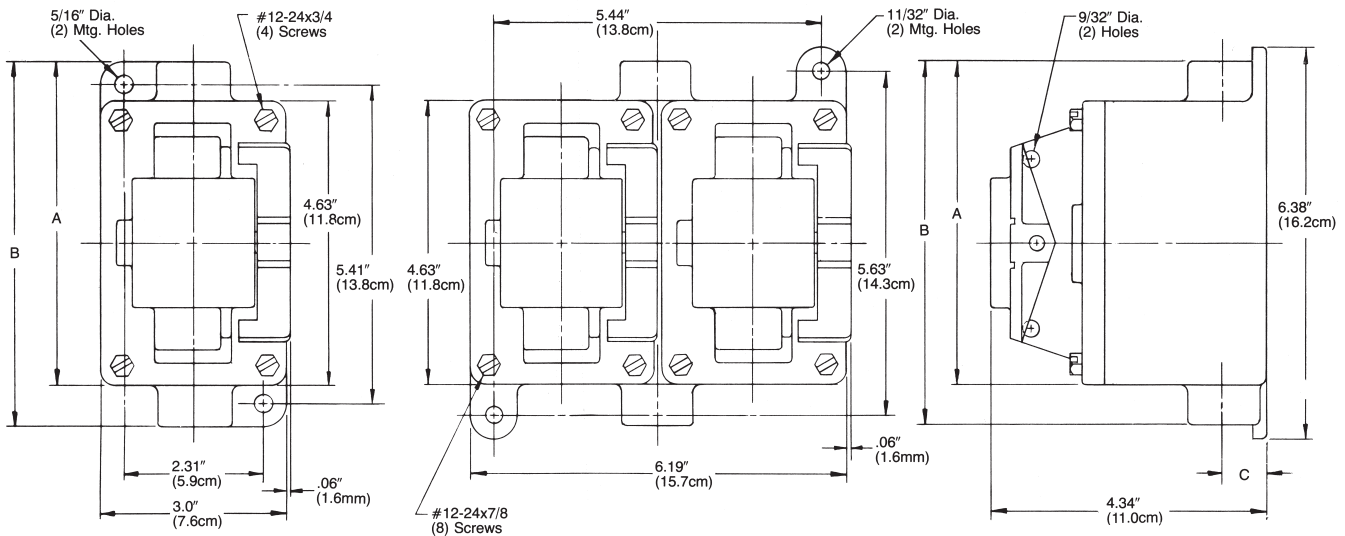

Hub Inches	Dimensions in Inches			Dimensions In Centimeters		
	A	B	C	A	B	C
1/2 & 3/4	5.38	6.13	.78	13.7	15.6	2.0
1	5.50	6.31	.94	14.0	16.0	2.4