



Installation Practices

for Dualoy 3000/LCX
coaxial fiberglass piping system
w/bonded clamshell fittings



ISO-9001



DNV

CERTIFICATED FIRM

Table of Contents

1	Introduction	3
2	Listings and approvals	3
3	Inspection, handling & storage	3
4	Materials	4
	Pipe	4
	Fittings.....	4
	Adhesive.....	4
	Tools.....	4
5	Field cutting & tapering primary pipe	5
	Cutting	5
	Removing containment	5
	Tapering with Ameron Taper Maker	5
	Tapering with power tapering tools	6
6	Piping system layout	6
	Trenching, bedding & backfilling	6
	Supporting valves, accessories & vent lines	7
	Precise alignment and make-up.....	8
	Flexible sump penetration fitting installation.....	8
	Jump-overs and Cross-overs	9
	Reducers	9
7	Bonding primary systems	10
	Joint preparation.....	10
	Mixing Ameron adhesive	10
	Applying Ameron adhesive.....	10
	Making the joint	10
	Pot life & cure time for Ameron adhesive	11
	Force curing Ameron adhesive	11
	Using heat blankets.....	11
	Connecting to non-Ameron fiberglass piping	11
8	Bonding containment piping	12
	Joint preparation.....	12
	Sealing containment piping	12
	Terminating the secondary containment	12
	Terminating inside the sump	12
9	NPT threaded connections	13
	Thread preparation.....	13
	Making the joint	13
	Isolating flex connections at the shear valve.....	14
10	Repair procedures	14
	Minor damage	14
	Major damage	14
11	Primary system testing	15
	Recommended practices.....	15
12	Containment system testing	15
	Pneumatic testing.....	15
	Provisions for testing and monitoring	15
13	Simultaneous testing	16
14	Health & safety information	16
	Toxicity of adhesive	16
	Handling precautions for adhesive	16
	First aid for adhesive users	16
	Important Notice	16

1 Introduction

Dualoy 3000/LCX pipe and fittings are manufactured from thermosetting epoxy resins reinforced with high tensile strength fiberglass filaments. The pipe is produced by filament winding. The pipe incorporates a resin-rich inner liner that is resilient and holiday-free and a resin-rich outer coating that protects the structural wall from UV degradation during storage and installation. The structural wall strength of Dualoy 3000/LCX pipe is unsurpassed in the fiberglass pipe industry. Fittings are manufactured by filament-winding or compression molding.

Dualoy 3000/LCX pipe and fittings are electrically nonconductive and never require cathodic protection or sacrificial anodes. Installed systems are immune to external corrosion from stray-current electrolysis and cathodic interference. They are unaffected by alkaline or acidic soil conditions.

The containment on the pipe is coaxial and an integral part of the piping. The containment over the fittings is made by applying matched clamshell fittings over the primary fitting, connecting the pipe containment jackets.

The primary piping and containment fittings are joined using the same, strong, reliable, bonded joint as in Dualoy 3000/L single wall piping.

Dualoy 3000/L single-wall piping systems

Detailed installation instructions for Dualoy 3000/L single-wall piping may be found in Ameron Bulletin 7501 (FP104) available from Ameron Fiberglass Pipe Group or your Ameron distributor.

2 Listings and approvals



Underwriters
Laboratories Inc.™

Dualoy 3000/LCX is Listed in the United States with Underwriters Laboratories for nonmetallic underground piping for petroleum products, alcohols and alcohol-gasoline mixtures (File MH9162). Dualoy 3000/LCX pipe & fittings are also listed with Underwriters Laboratories of Canada for Petroleum Products and Oxygenated Fuels (File CMH715).

3 Inspection, handling and storage

Inspection

Careful inspection of the outer (secondary) layer of pipe is especially important on coaxial containment installations. Since damage to the primary is not visible once the pipe is installed, it is essential to check the outer pipe jacket for damage. Testing and experience has proven that no damage will occur to the primary pipe without an indication of damage on the outer jacket.

Upon receipt at the job site, inspect the pipe fully. Locate, cut out, repair or replace damaged pipe. Impact damage is usually recognizable as rounded pale areas just under the surface or as deep gouges, scratches or cracks. Remove end protectors to inspect tapers for damage and then replace protectors.

Handling

Dualoy 3000/LCX has higher impact resistance than single-wall pipe, however, fiberglass pipe is susceptible to damage if handled improperly. Adhere to the following recommendations when handling:

- Do not transport pipe without proper protection against impact.
- Truck pipe racks should be padded with carpeting or like material to prevent damage.
- Tie the pipe down during transport to prevent it from bouncing on the racks.
- Do not use chains to tie down the pipe on a truck: Use nylon straps or hemp rope.
- Do not drop the pipe from truck bed when stringing: Lay the pipe down by hand.
- Pipe loads that are properly separated and supported can be unloaded by padded forklifts.

Storage

Dualoy 3000/LCX pipe incorporates a 5-mil thick, resin-rich outer coating which provides outstanding UV resistance. Pipe stored out-of-doors for extended periods may assume a chalky appearance. However, this change in appearance is superficial and does not affect the pipe's performance. Protect stored pipe from impact damage by stacking on padded racks.

4 Materials

Pipe

Manufacturer tallies pipe on the basis of overall length. Allow for cutting losses and wastage when ordering.

Fittings

Contained fitting assemblies are sold in the following boxed quantities.

Clamshell Fittings per Shipping Box							
Nominal Pipe Size (in) (mm)	90° Elbows		45° Elbows		Tees	Sleeve Couplings	Termination Sleeves
	2 50	5	5	5			
3 80	5	5	5	5	10	10	
4 100	5	5	5	5	10	10	

Note: Fasteners are included with fittings.

Adhesive

Ameron supplies PSX™•20, PSX™•34 and B-20 adhesives. The PSX™•20 and PSX™•34 adhesives are polysiloxane-modified epoxy formulations. All are designed to make permanent bonds in primary or containment systems containing petroleum products, alcohols, alcohol-gasoline mixtures or oxygenated fuels. They are also approved for use with MTBE fluids. Each is supplied as a two-part system consisting of a resin and a hardener.

Each adhesive kit contains:

- Resin
- Hardener
- Mixing stick
- Spatula and/or brush
- Detailed usage instructions
- Emery paper
- Gloves
- Paper towels

Refer to the layout drawings to estimate the number of adhesive kits required. Include bonds for all fittings, elbows, tees, reducers, adapters and couplings plus a waste factor. Short pot life at higher temperatures may not allow as many bonds to be made as indicated in the table: allow a greater waste factor at higher temperatures. For further information refer to the adhesive product data sheet.

Primary Bonds per Kit ¹					Containment Bonds per Kit ¹				
Nominal Pipe Size		Adhesive Kit Size			Nominal Pipe Size		Adhesive Kit Size		
(in)	(mm)	3 oz. ²	5 oz. ²	8 oz. ^{2,3}	(in)	(mm)	3 oz. ²	5 oz. ²	8 oz. ²
2	50	6	12	—	2	50	1	3 ³	4
3	80	3	8	14	3	80	1 ³	1	2
4	100	2	6	9	4	100	1/2	1/2	1

1 The average number of primary system bonds obtainable by an experienced crew at 75°F.
 2 Available in six-pak kits.
 3 Excessive waste may result when using the 8-oz kit to make 2-inch bonds.

1 The average number of primary system bonds obtainable by an experienced crew at 75°F.
 2 Available in six-pak kits.
 3 Fewer bonds on tees would be typical, more for termination sleeves.

Tools

The following tools are recommended to install Dualoy 3000/LCX piping:

- 3/8-inch electric drill or equivalent air-driven motor
- Fine blade hacksaw, radial cut off saw or circular saw
- 5- or 6-inch hole saw for installing sump penetration fittings
- Large pliers capable of gripping a 4-inch object
- Containment jacket stripping tool
- 1 1/2-inch disc grinder wheel for abrading sump wall at penetration
- Heat blankets, heavy-duty heat guns, or hot air blowers for cool/cold-weather installation.
- Tapering tool as described on the next page.

When using pneumatic tools, the air supply must be dry and oil-free as moisture or oil on bonding surfaces will interfere with the adhesive.

5 Field cutting and tapering primary pipe

Cutting

Use a fine-blade hacksaw, radial cut-off saw or circular saw with abrasive wheel to cut pipe in the field. The cut end must be square to within $\frac{3}{16}$ inch (5 mm).

Hold pipe securely for all cutting and tapering. When using a pipe vise, always wrap the pipe with a protective material such as a $\frac{1}{4}$ -inch thick rubber pad. Take care not to damage or over-deflect the pipe when tightening the vise.

Removing containment with jacket cutting tool

The jacket cutting tool is used to quickly remove the containment layer from the end of the pipe. The tool makes tapering of the pipe easier, reduces wear on the tapering equipment and provides a square finished edge to the containment. The tool consists of a pneumatic grinder equipped with a diamond cut off wheel. It is adjustable to allow it to be set at the desired height to cut through the containment without any risk of cutting into the primary pipe.

The jacket cutting tool, the tool can either be clamped into a vise or can be hand operated if the pipe is clamped into a pipe vise.

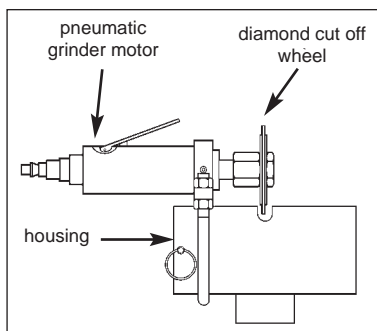

Fig. 5-1. Ameron 2" jacket cutting tool

- Remove the containment by activating the grinder and inserting the end of the pipe into the housing.
- Push the pipe into (or onto) the tool to cut a longitudinal groove in the containment.
- When the end of the pipe reaches the stop at the back of the tool, rotate the pipe (or tool), cutting the containment circumferentially.
- When cutting the jacket of a pipe to be used with a termination sleeve, a longer cut of jacket is needed to allow enough room to bond to both the primary and containment pipe. Minimum dimensions are shown in the table above.
- Rotate back to the starting position and remove the pipe from the tool.
- Physically remove the containment layer by prying it open slightly and pulling it off the primary. Use care to not damage the primary pipe during this operation.

Nominal Pipe Size		Containment Removed To Bond into a Fitting		Containment Length Removed To Use Termination Sleeve	
(in)	(mm)	(in)	(mm)	(in)	(mm)
2	50	2.75	70	3.50	91
3	80	2.75	70	4.00	102
4	100	3.50	91	4.50	114

Note: The cut off wheel will wear down eventually and may need readjustment to cut through the containment. To adjust, set the depth so that the wheel cuts just to the tape layer and not into the sand layer. This will minimize wear on the wheel.

See Universal Jacket Cutter Operating Instructions (FP817) for 2" thru 4" containment cutting and removal.

Fig. 5-2. Universal Jacket Cutting tool. Safety guard is omitted for clarity.

Note: Pin and rods are adjustable for 2", 3" and 4" sizes. Pin must be in proper position for size to give correct depth of cut.

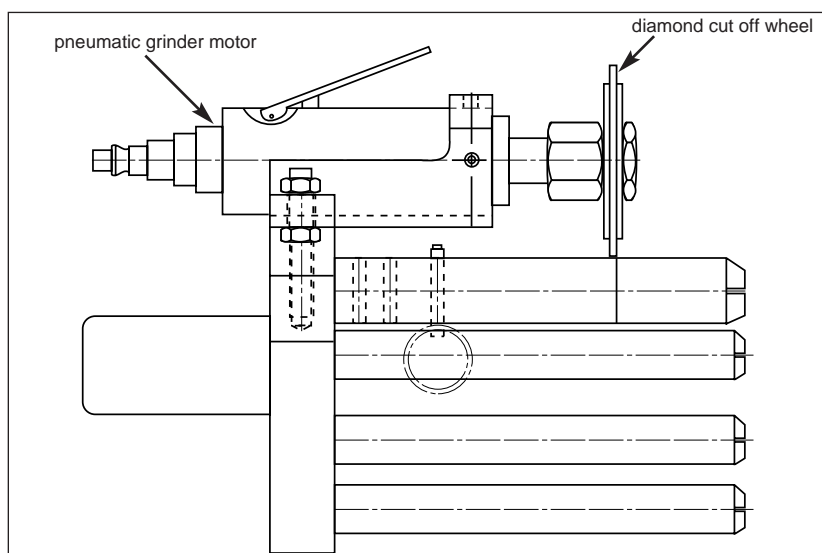

5 Field cutting and tapering primary pipe (cont'd.)



Fig. 5-3. Dualoy 3000/LCX can be tapered using the Ameron Taper Maker. The ratchet handle makes the Taper Maker convenient to use in confined spaces when repairing existing lines.



Fig. 5-4. Pipe is typically tapered using one of several power tapering tools available from outside sources.

Tapering with power tapering tools

Pipe is most often tapered using one of several power tapering tools. Manufacturers' names and addresses may be obtained from Ameron distributors. Pipe tapered with these tools should be periodically checked against a factory taper for taper length and taper angle.

On 2" pipe, it may be possible to simultaneously remove the containment jacket and taper the primary pipe in one step with some power tapering tools. Consult Ameron engineering department for information.

Observe the following procedures when operating the Taper Maker.

- Check blade angle by using a factory taper as a guide. When properly adjusted, the blade should be in contact with the taper over the entire taper length. If adjustment is required, loosen the blade retaining screws and adjust the blade angle with the set screw.
- Mark the required taper length on the pipe. Refer to the taper length table below.
- Insert the threaded collet shaft through the base casting and the mandrel.
- Select the appropriate size collet and slide it onto the mandrel, making sure the key inside the collet engages the slot of the mandrel.
- Hold the collet and turn the collet control knob clockwise until the collet begins to expand. Note that it may be necessary to adjust the cutting head to accommodate different size collets.
- Insert the collet into the pipe until the back end is flush with the end of the pipe.
- Expand the collet to grip the inside of the pipe by turning the collet control knob clockwise.
- Lower the cutting blade until it contacts the pipe by turning the cutting head adjustment handle clockwise.
- Using the ratchet handle, turn the tool clockwise, gradually lowering the cutting blade by turning the cutting head adjustment handle clockwise. Continue until a smooth taper of the proper length is obtained. The thin edge of the completed taper should be no less than 1/32 inch (0.75 mm) thick.

Nominal Pipe Size	Taper lengths				Containment Removed	
	Taper Length				min. (in., mm)	
(in)	(mm)	(in)	(mm)			
2	50	1 1/2	38	2 1/4	70	
3	80	1 3/4	44	2 1/4	70	
4	100	1 7/8	48	3 1/2	89	

For complete operating information, refer to the appropriate Taper Maker Product Data/Operating Instructions.

6 Piping system layout

Trenching, bedding and backfilling

The smaller outside diameter of the Dualoy 3000/LCX coaxial pipe will save on trenching and backfilling costs. The ability to fabricate close "Jump-Over" fittings also helps reduce the depth of excavation needed to maintain trench slope. Although fiberglass pipe has excellent strength, it must be protected against impact which may occur from improper handling or during backfilling.

- Provide a trench width equal to the pipe diameter plus six inches on each side. Separate multiple lines by at least 4 inches. Refer to Fig. 6-2.
- Provide a minimum of 18 inches of select backfill between the top of the pipe and unpaved ground surfaces.
- Provide a minimum of 4 inches of select backfill between the top of the pipe and reinforced concrete pavement (4 inches minimum thickness).
- Provide a minimum of 8 inches of select backfill between the top of the pipe and asphalt pavement (2 inches minimum thickness).
- Slope the trench bottom evenly from the dispensers back to sumps or tanks at a minimum slope of 1/8 in/ft.
- The trench bottom must be free of hard or sharp objects.

6 Piping system layout (cont'd.)



Fig. 6-1. During layout, bonding and inspection, support the piping on 2x4 "batter boards" to keep the joints clean and to keep bedding out of the pipe.

Fig. 6-2. Use only select materials for bedding and backfilling Dualoy 3000/LCX fuel handling systems. Native materials are rarely suitable and should not be used.

- Grade the trench bottom with at least 6 inches of select backfill to provide firm, even support for the pipe. Compact the subgrade well to prevent differential settling.
- Protect the pipe from impact during backfilling and abrasion during operation by surrounding it with four to six inches of select backfill such as washed sand, pea gravel (¾-inch maximum) or crushed stone (½-inch maximum).
- Wrap pipe lying near concrete with rubber or foam padding to avoid direct contact with the concrete.

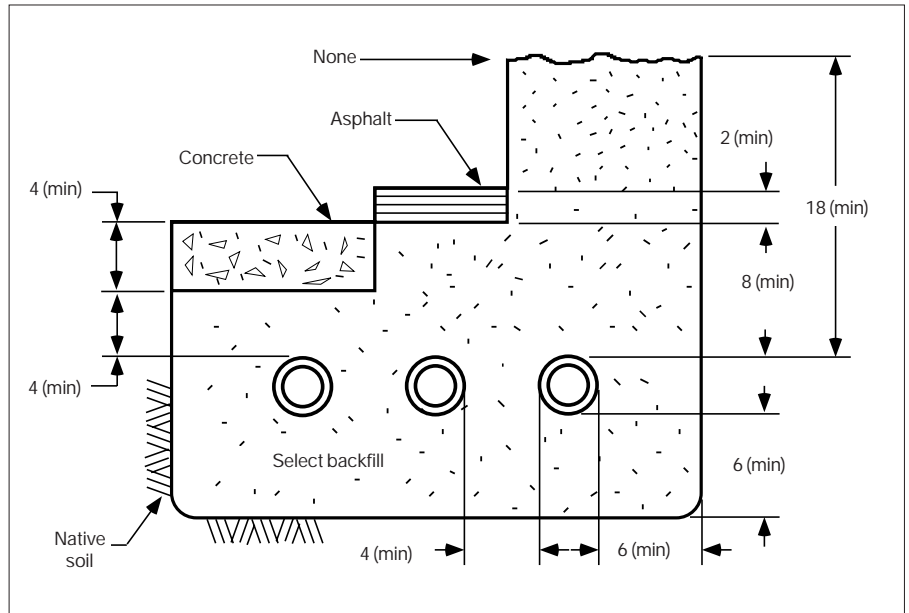

Supporting valves, accessories and vent lines

Do not use fiberglass pipe to support the weight of heavy items in a line such as valves, strainers and steel vent riser pipes. Provide separate supports for valves and accessories.

Fig. 6-3. Support risers by attaching them directly to structure walls.

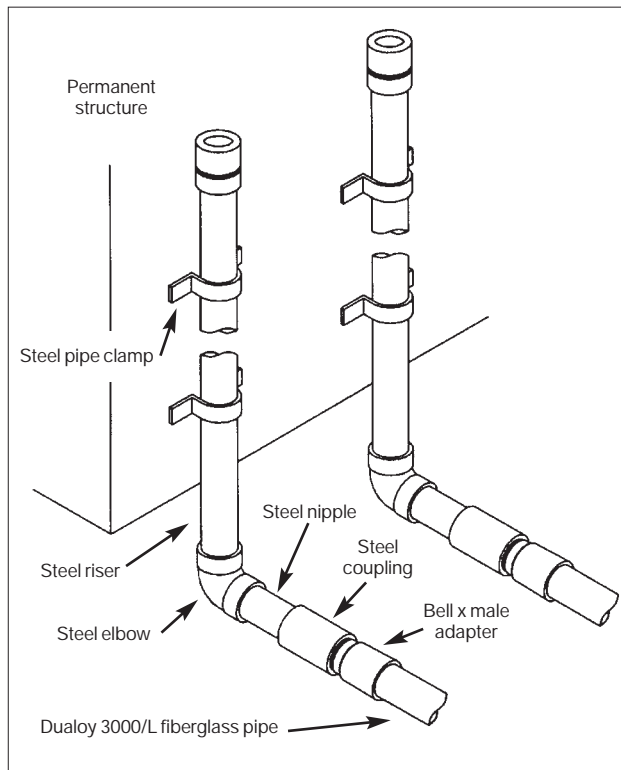

6 Piping system layout (cont'd.)

Fig. 6-4. Use flexible connectors to connect fiberglass pipe to tanks, turbine outlets at tanks and to shear valves at dispensers. A 4-ft. minimum length of fiberglass pipe (dogleg) is allowable per API Specification 1615 in lieu of a flexible connector.

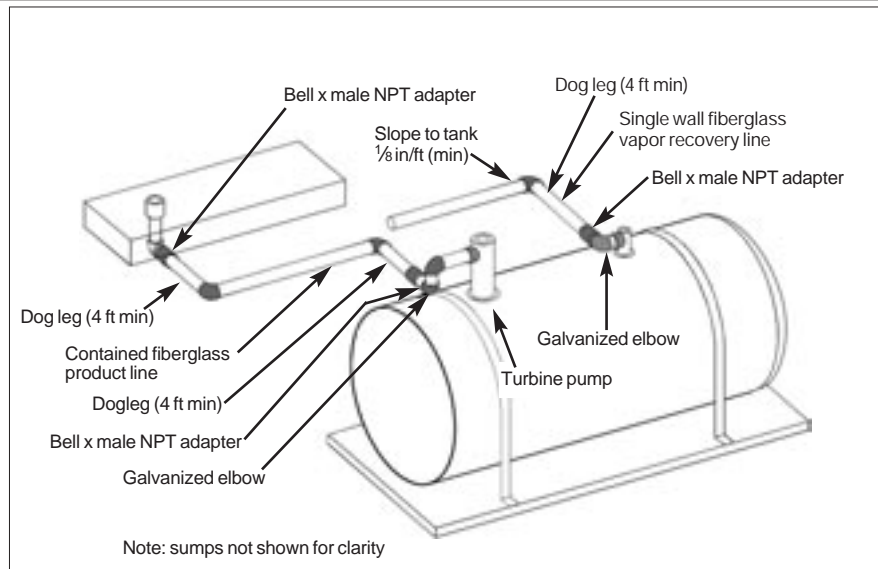

Precise alignment and make-up

The matched taper bell and spigot joint on the primary does not always result in a precise and predictable insertion depth. This variation results from:

- Manufacturing tolerances in the bell
- Differences in length of tapers prepared on the job site
- Difference of insertion depth when dry fit and after adhesive has been applied.

Flexible sump penetration fitting installation

- Measure to the appropriate height for the center of the hole, making sure to allow for the desired slope for the piping in the station layout.
- Mark the height across sump.
- Measure and mark the location of each penetration on the line, on the flat panel.
- Using a 5-inch hole saw for dispensers, 6-inch for tanks, cut a hole for the penetration fitting.
- Sand and clean the edges to create a smooth surface to properly seat the fitting in the sump wall. (continued on page 9 at top)

Fig. 6-5.

a) Typical sump penetration detail for a system piped in parallel or at last sump of a system piped in series.

b) Typical sump penetration detail for a system piped in series and utilizing termination tees. Allows pressure rating on secondary of 30 psi.

c) Typical sump penetration detail for a system piped in series. Note: Low test pressure needed if connecting tube is pressurized.

Note: 24-inch minimum width recommended on dispenser sumps to facilitate series installations.

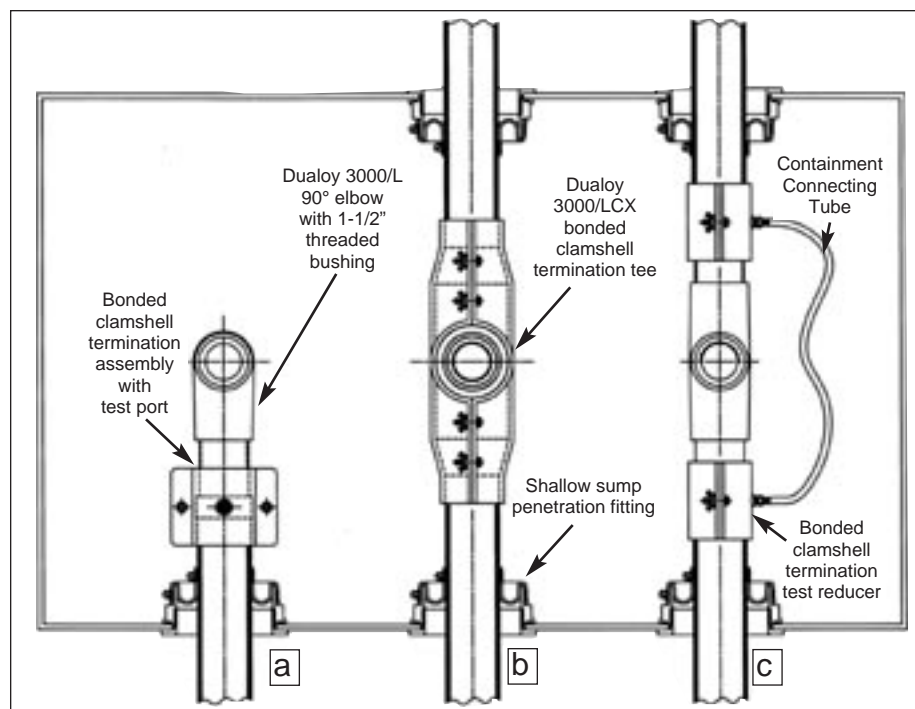

6 Piping system layout (cont'd.)

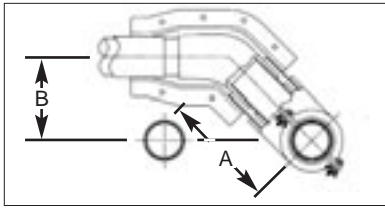

Fig. 6-6. Jump-over assembly made with next larger size single-wall pipe and clamshell fittings cut at start of taper to allow minimum length.

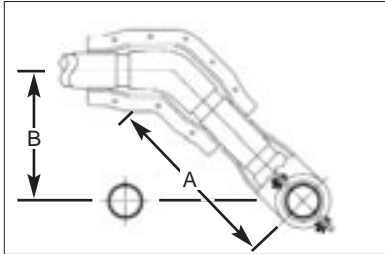

Fig. 6-7. Cross-over assembly made with LCX pipe and full clamshell fittings for installations where longer length is allowed or needed.

Flexible sump penetration fitting installation (cont'd)

- The flexible penetration fitting has two sections, an outer ring and an inner boot. Unscrew the ring from the penetration fitting and apply a small bead of Bostik 920 to the inner surface of the ring flange.
- Apply a bead of Bostik 920 around the hole on the inside surface of the sump wall.
- Place the ring into the sump wall from the outside with the threads inside the sump.
- Press the gasket into the groove on the inner part of the penetration fitting.
- From inside the sump, screw the penetration fitting onto the threads and tighten with adjustable pliers.

Jump-overs and Cross-overs

Assemblies for crossing lines can be made in one of two ways. For lines where the tee and 45° elbow need to be very close (a Jump-over), the clamshell fittings can be cut at the beginning of the tapered portion on the branch of the tee and one leg of the elbow. A piece of single wall pipe of the next larger size can be used to connect the clamshell fittings (Fig. 6.6). For lines where there is sufficient distance between the tee and 45° elbow to allow for the full clamshell fittings, the cross-over can be made by simply bonding the fittings and clamshells to a piece of standard coaxial pipe. (Fig. 6.7)

Nominal pipe diameter (in.) (mm)	Minimum Length (A)				Minimum Height (B)				
	Jump-Over		Cross-Over		Jump-Over		Cross-Over		
	(in.)	(mm)	(in.)	(mm)	(in.)	(mm)	(in.)	(mm)	
2	50	7½	190	12 ⁵ / ₈	320	5¼	135	9	227
3	80	9¾	250	14 ³ / ₄	375	6 ⁷ / ₈	175	10½	265
4	100	10¼	260	16½	420	7¼	185	11 ⁵ / ₈	295

Reducers

The Dualoy® 3000/LCX Coaxial Piping System can be reduced from 3" to 2", 4" to 3" and 4" to 2". See Figure 6-8.

Mark the "X" Dimension on the outside of smaller secondary prior to bonding primary:

- Sand bonding surface of jacket.
- Apply adhesive and place clamshell reducer ring in place. Allow adhesive to cure.
- After all primary bonding, curing and testing is complete, bond clamshell containment fitting in place on larger secondary pipe and clamshell reducer ring.

Reduction	(X)
3" to 2"	3¾
4" to 3"	4¼
4" to 2"	4¼

Fig. 6-8. Reducer

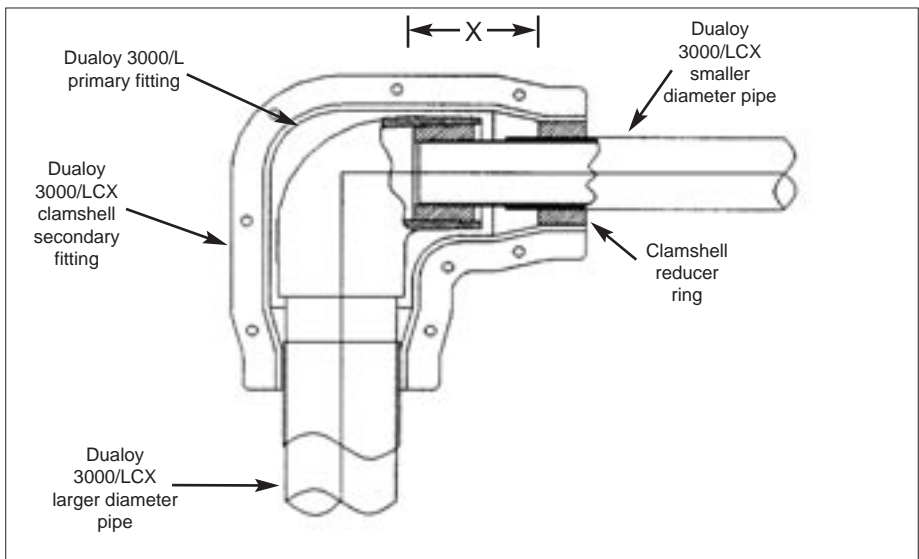

7 Bonding primary systems

The hardener contained in the adhesive kit may burn the skin. Avoid inhaling the vapors. Read and observe the label precautions.



Fig. 7-1. Tapered pipe ready for dry fit.

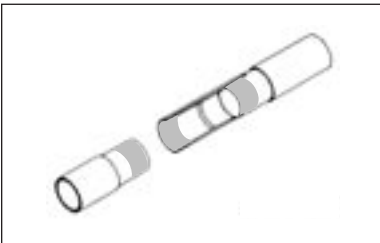

Fig. 7-2. Completely wet all matching surfaces with the adhesive. Wipe off excess adhesive with the spatula provided in the kit.

Joint preparation

All tapered systems must be clean, dry and warm for a proper bond.

Clean: Pipe is shipped from the factory with end protectors. Avoid contamination from fingerprints, petroleum fumes, mist and condensation as these are adverse to good bonding. If a taper becomes dirty, sand it with emery cloth. Never touch the bonding surface with bare hands after cleaning or sanding as this will leave an oily deposit.

Dry: Adhesive will not bond to a wet surface. If the taper is wet or moist, dry it with a blow dryer or heat gun. Do not overheat or burn the pipe.

Warm: Below 50°F (10°C), warm the taper with a blow dryer or heat gun. For best results, adhesive should be at least 50°F when used. Do not store kits in areas above 100°F (38°C), below 32°F (0°C), or in the direct sunlight during warm weather. In cold weather, warm the resin to at least 50°F but not above 100°F to permit good mixing and easier application.

Mixing Ameron adhesive

- Combine all of both components in the mixing container in the supplied proportions.
- **Never try to split a kit.**
- Mix thoroughly with the mixing stick until all streaks are gone and the adhesive has a smooth, uniform color. Mixed adhesive color is dark red.
- **Do not allow moisture to get into the can.**

Note: If the material in either container cannot be mixed, the kit should not be used. Grit in adhesive may be sitting on top of resin component. It will mix in readily.

Applying Ameron adhesive

PSX™•20 and PSX™•34 adhesives contain grit to aid in installation. Excessive amounts of adhesive may (1) cause flow restriction inside the pipe when the adhesive has cured, (2) block the opening of the containment pipe, or (3) result in 'hydraulic backout' as the adhesive cures. Hydraulic backout occurs when excess adhesive prevents the joint from maintaining an interference fit and the spigot backs out of the bell during cure. The inclusion of grit reduces this possibility significantly.

Coat the tapered surface and coat end of the primary pipe or the entire tapered section of adapters with adhesive. Apply a **thin**, even coat of mixed adhesive to the inside of the bell of fittings. Completely wet all matching surfaces with the adhesive. Wipe off excess adhesive with the spatula or brush provided in the kit.

At fittings where the containment is to be terminated, take care when applying adhesive so excess adhesive does not get on primary pipe where termination sleeves will need to seal.

Making the joint

After aligning the mating surfaces so that they may be brought together in a straight line:

- Insert spigot all the way into the bell.
- Twist one quarter of a turn, when possible, while pushing together to distribute adhesive evenly and to achieve an interference fit. A slight reverse twist will then lock the joint.
- Remove any excess adhesive.
- Do not cock the joint.
- Over-insertion of the joint may collapse the spigot and cause a leaky joint.
- Under-insertion of the joint may also cause a leaky joint.
- Do not drive the joint together with a hammer.
- Do not disturb the joint while the adhesive is uncured.
- Do not move adjacent pipe and fittings until adhesive has set.

7 Bonding primary systems (cont'd.)

Temperatures in a trench or out of direct sunlight may be lower than measured ambient surface temperatures.

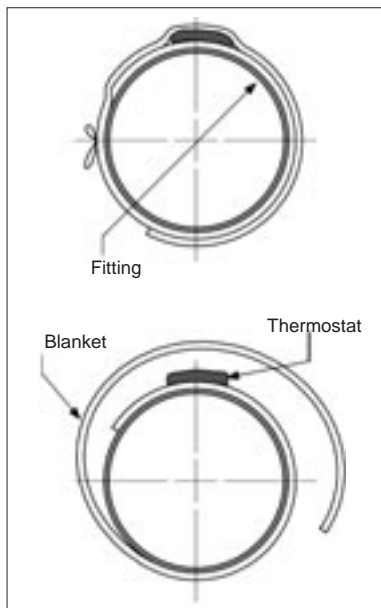

Fig. 7-3. Place the thermostat end of the blanket against the joint with thermostat facing out. Wrap the rest of the blanket around the joint so that the overlap covers the thermostat.

Fig. 7-4. When it is below 50°F (10°C), close the pipe ends and insulate around the blanket. Overlap the blanket about 4 inches on each side and tie down the ends of the insulation.

Pot life/cure times for Ameron adhesive

Pot life is measured from the time the hardener and resin are first mixed until the adhesive starts to thicken and harden and no longer can be used. Do not use adhesive once the can has become hot.

The table below indicates the adhesive pot life under various temperature conditions. In hot weather, pot life may be extended by wrapping a damp rag around the can of mixed adhesive or by spreading the adhesive on aluminum foil to dissipate the heat.

Pot life/cure times for Ameron adhesive			
Minimum Ambient Temperature		Adhesive Pot Life	Minimum Joint Cure Time*
(°F)	(°C)	(minutes)	(hours)
40	5	70	12
65	18	40	5
75	24	30	4
95	35	20	3

* Cumulative totals. Cure time at listed temperatures need not be uninterrupted, but total time must equal the tabulated time before the system is pressure tested.

Force curing adhesive

At temperatures below 50°F (10°C) or if the temperature will not be above 50°F (10°C) during the entire period of cure, an external heat source must be used to force cure the adhesive. The adhesive and the bonding surfaces should be warmed to 50°F (10°C) before mixing and applying the adhesive.

Below 50°F (10°C) force cure the adhesive with an external heat source such as:

- Ameron LCX heating blanket
- Forced air heater if the trench is covered to contain the heat
- Hot air gun

Using Ameron heating blankets

The heating blanket reaches a maximum temperature of 300°F (150°C), which will cure Ameron adhesive in approximately 30 to 40 minutes. Detailed instructions are included with the blanket. Observe the following points:

- Use one heating blanket per bond.
- Tie the blanket in place with nonconducting ties.
- Before connecting to a power source, inspect the blanket and cord for loose wire connections and bare wires.
- Do not plug the cord into a power source when standing in water or on a wet surface.
- Check that the heating blanket has the correct AC voltage rating for your locality. Do not use direct current.
- Mark the starting and disconnect time on the pipe with a grease pencil so that you will have a record of cure for each joint.
- Verify that the blanket actually heats up after being plugged in.
- Do not move or disturb the joint during cure.

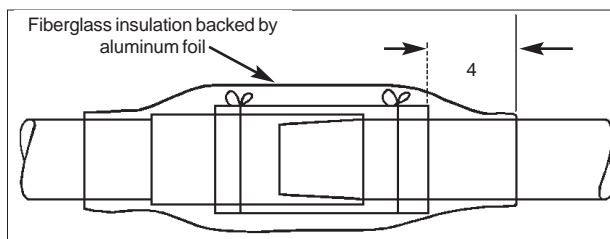

Connecting to non-Ameron fiberglass primary piping

Connect Dualoy 3000/LCX fiberglass piping and non-Ameron UL Listed fiberglass primary piping by means of threaded adapters. Do not adhesive bond Ameron piping to that of another manufacturer. Bond the appropriate adapter from each manufacturer to the manufacturer's pipe using that manufacturer's adhesive. Complete the threaded connection using thread sealant, not pipe adhesive. By following this procedure you can use Dualoy 3000/LCX piping to extend an existing line that employs the pipe from another manufacturer without affecting the UL Listing of either system.

8 Bonding containment piping



Applying adhesive to the flanges and the curved surface of the fitting where the pipe will fit.



Adhesive applied to the outside of the containment pipe.



Completed connection with bolts in place.

Fig. 8-1. Assembly sequence to seal the containment of the Dualoy 3000/LCX fitting.

Joint preparation

Inspect all sealing surfaces to insure they are free of any foreign material such as dirt, sand, or adhesive. (Compressed air works very well for removing foreign material.)
Inspect all sealing surfaces to insure there are no cuts, scratches, or nicks which could prevent the joint from sealing properly.

Adhesive for containment piping

The same PSX™•20 adhesive used for primary bonding is used for bonding containment fittings.

Sealing containment piping

- Bond containment only after primary lines have been tested, inspected and approved.
- All bonding surfaces must be free from water, soap, oil, grease, dirt and other contaminants and should be sanded before applying adhesive.
- Apply a uniform coating of adhesive to the flanges of each of the containment fitting halves, to the outside of the containment pipe and to the curved surface of the fitting where the pipe will fit. Keep adhesive off the last 1/2 inch of the pipe jacket when applying it to the pipe.
- Place the containment half-shells around the primary fitting. Since the primary assembly of the Dualoy 3000/LCX is rigid relative to the containment piping, the containment fittings will not have to be held so tightly that they must resist containment pipe movement. Once in place, assemble fasteners supplied with the fittings to hold the halves in place until the adhesive cures. See Figure 8-2.

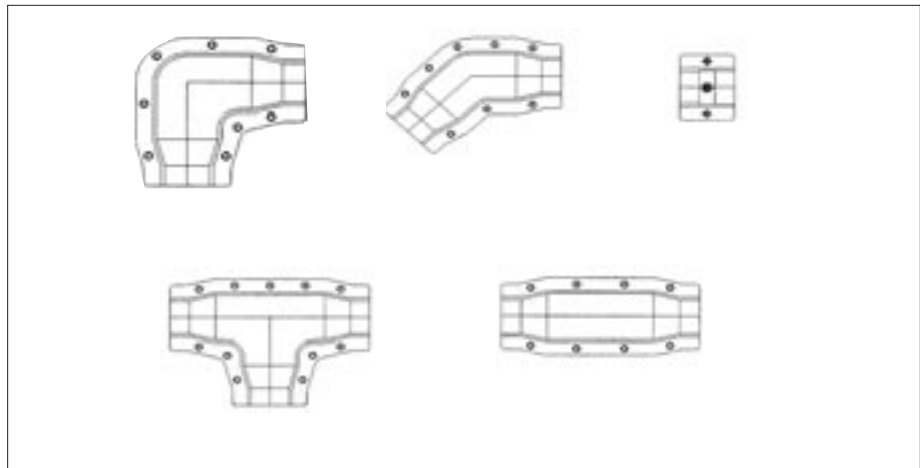

Fig. 8-2

Terminating the secondary containment

• Clamshell termination assembly

Apply adhesive to all bonding surfaces after sanding, as described above. Position the clamshell termination assembly over the cut jacket so that the jacket end is centered in the clamshell. Particular care must be given to assure excess adhesive is not used as it may cause sealing of the containment. See Figure 8-3.

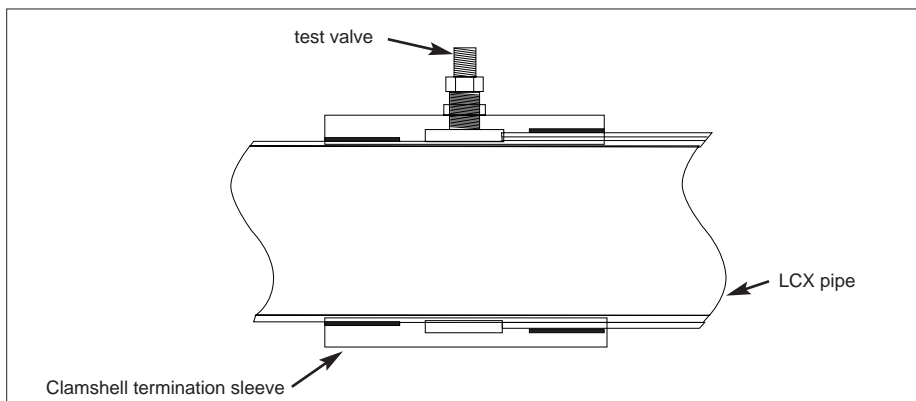
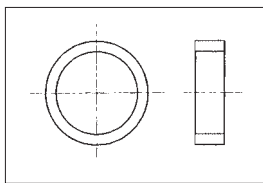
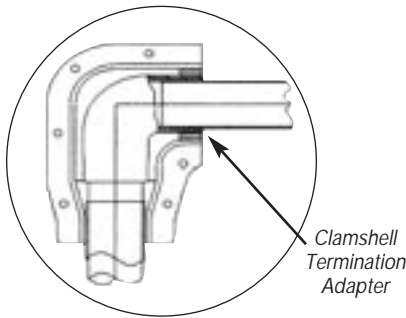

Fig. 8-3. Dualoy 3000/LCX molded termination assembly to seal off secondary containment. 2" available with or without test valve. 3 and 4" are available only with test valve.

8 Bonding containment piping (cont'd)



Clamshell Termination Adapter
(front & side)

Terminating inside the sump

For series lay-out patterns, the means of terminating the containment of the branch leg of the in-sump tee or elbow is with a bonded termination adapter. The adapter is bonded to the exterior of the fitting leg to be terminated, prior to the clamshell containment fitting being placed on the assembly.

- Lightly sand the outside surface of the leg of the primary fitting on which the termination is to be done.
- Abrade the inner surface of the termination adapter also, to provide a fresh surface to which to bond.
- Cut the tapered end portion of the containment fitting leg which is to be terminated. Abrade the inner surface of the shortened leg of the containment fitting to prepare it for later bonding.
- Apply a moderate coating of adhesive to outer surface of the primary fitting and the inner surface of the termination adapter. Keep the outer surface of the adapter dry and free of adhesive.
- Fit the adapter onto the primary fitting.
- Dry fit tapered Dualoy 3000/LCX pipe legs into the bell ends of the primary fittings which are not to be terminated.
- Place the clamshell containment fitting over the primary fitting-adapter assembly and hold in place with bolts while the adhesive cures. This will assure proper alignment of the adapter for final assembly. Care should be taken to assure adhesive does not touch the clamshell fitting at this point as it is to be removed when the adhesive between the primary fitting and the adapter is cured.
- Once the adhesive has cured, remove the bolts and the clamshell fitting. Install the assembled primary fitting into the primary system.
- Use the prepared clamshell fitting to close the containment system when primary testing and inspection is done.

9 NPT threaded connections

On bell x female adapters, use pipe wrench over threaded portion only. On bell x male adapters, use pipe wrench on steel nipple whenever possible.

In general, threaded connections should be made up before adhesive-bonded joints to minimize the possibility of damage to bonded joints caused by torquing the threaded connections. However, when installing molded threaded bushings (tapered major nominal pipe size x threaded minor nominal pipe size) make the tapered bonded joint first and allow it to cure before making up the threaded joint. This order of joint make-up will prevent damage to the bushing.

Thread preparation

- Inspect threads on fiberglass adapters and threaded bushings. Do not use if threads are damaged.
- Inspect threads on steel fittings for burrs.
- Remove burrs from steel fittings by making up to mating steel threads. Unmake the steel fitting and reinspect.
- Always dry fit fiberglass and steel threads without sealing compound. It should be possible to dry fit the threads as shown in the following table. If the proper number of threads cannot be made up, select a new steel fitting.

Making the joint

Threads must be clean and dry before applying thread-sealing compound.

- Use a nonhardening, solvent-free Teflon based thread sealant such as Jomar Seal "The Heavyweight" or Gasoila Soft Set pipe sealant.
- Apply sealing compound to male and female threads.

- Hand tighten the joint, then use a wrench to get full make-up. Standard pipe wrenches can be used with care on fiberglass adapters. Do not overtighten.
- The parts should make up the number of threads shown in the table above. Otherwise, a proper seal may not be effected when tightened.

Threads to Dry Fit and to Seal

Nominal Pipe Size	Threads to Dry Fit and to Seal	
	(in)	(mm)
1½	40	4-5
2	50	4-5
3	80	5-6
4	100	6-7

9 NPT threaded connections (cont'd)

Never use a pipe wrench directly on the pipe: wrench up only on adapters.

Isolating flex connectors at the shear valve

When flex connectors are directly buried at the dispenser, regulations frequently require that they be cathodically protected and provisions be made to avoid stray current electrolysis and corrosion. In such cases the flex connector must be electrically isolated from the shear valve and from other metallic components in the system. Experience has shown that nylon isolation adapters do not perform well inasmuch as the poor mechanical strength of the material results in creep or thread deformation with subsequent leakage.

Ameron manufactures a 1½ NPT female x 1½ NPT male fiberglass-reinforced isolation adapter which may be mounted between the flex connector and the shear valve. Follow the same general installation procedures as with other NPT threaded fittings. After applying the sealing compound, hand tighten the adapter. Final make-up requires 1½ to 2 additional turns.

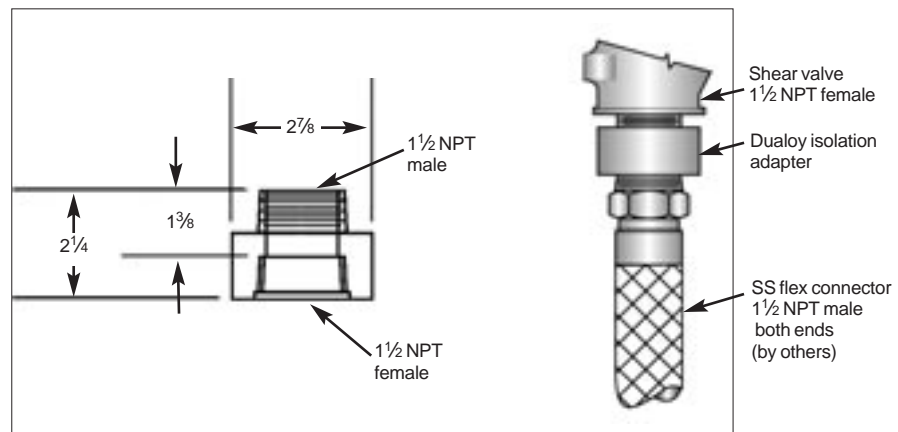

Fig. 9-1. The Ameron fiberglass-reinforced isolation adapter is mounted between the flex connector and the shear valve.

10 Repair procedures

Dualoy 3000/LCX is very resistant to impact damage. It can be damaged, however, by paving stakes, large concrete pieces or other hazards. In the event of damage, the pipe can be repaired using these procedures.

Usually the damaged area is obvious. If the exact location of the damage cannot be determined, it may be necessary to replace that full length of pipe. Standard leak detection methods (soapy water) can be applied progressively along the length of pipe to locate the damaged or defective section. If the primary pipe is leaking at an unknown location, the cut ends of the jacket at each end of each piece of pipe can be soaped to isolate the leak. If the containment pipe is leaking, the surface can be soaped.

Minor damage (isolated to less than one inch of pipe length)

- Cut out the damaged pipe.
- Remove the jacket and taper each of the ends of the remaining pipe
- Assemble primary coupling following standard installation practices.
- Assemble containment coupling following standard installation practices.

Minor damage [containment only] (isolated to less than one inch of pipe length)

- Sand area around damaged area - approximately one inch in all directions.
- Recover cut jacket section from jacket cutter, remove tape and sand from inner surface. Sand inner surface.
- Apply thin coating of adhesive to sanded surfaces.
- Wrap jacket section over pipe and secure in place until adhesive cures.

Major damage (greater than one inch of pipe length)

- Remove at least 15 inches of pipe length or the full length of pipe if damaged area is greater.
- Remove the jacket and taper each of the ends of the remaining pipe
- Dry fit two couplings and intermediate pipe nipple into the gap.
- Proceed as above for each end of repair area. Finished repair is as shown on the next page.

10 Repair procedures (cont'd)

Once the pipe is buried and the site is paved, repair requirements are extremely rare for Dualoy 3000/LCX. If the pipe does become damaged, sections can be isolated and tested between sumps to locate the problem area. Pavement may need to be removed to access the damaged pipe.

Fig. 10-1. Completed repair section using Dualoy 3000/LCX coupling assembly

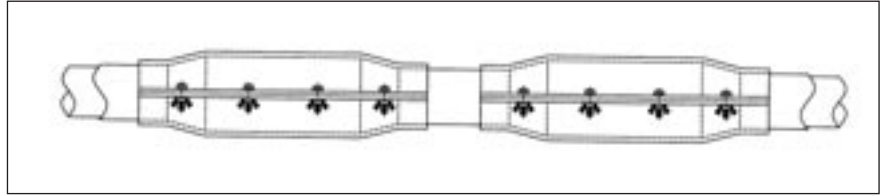

11 Primary system testing

These recommendations are offered only as a guide. Ameron assumes no responsibility or liability for the consequences of any testing practices.

Ameron recommends hydrostatic testing of primary systems as the effects of sudden pressure loss when testing with liquids are far less severe than with gases. If pneumatic testing is necessary, restrain the system adequately to prevent damage or injury in case of rapid pressure loss. Pneumatic testing can be extremely dangerous and is not recommended.

Recommended practices

Plan tests carefully and carry them out with all due precautions. Pressurizing equipment should be suited to the size of the system and the pressure required and should be operated by qualified and experienced personnel only.

- Pressure sources should be capable of approaching test pressure gradually.
- Use gauges with a full-scale reading of no more than twice the test pressure: Do not use a 100 psi gauge for a 10 psi test. Use reliable gauges calibrated against a dead weight tester and zeroed for atmospheric pressure.
- Isolate tanks from the piping when pressure testing.
- The recommended hydrostatic pressure is 150% of expected operating pressure and should be maintained at least 10 minutes.
- Do not exceed 150% of system rating. Check the pressure rating of all the components of the system—not just the pipe—because hoses and flexible connectors are almost always rated lower than the pipe.
- Do not adjust fittings while system is under pressure. If threaded adapters or bushings leak, release the pressure before attempting to tighten.
- Temperature changes can affect the pressure in the test line. Substantial pressure increases may occur in closed systems exposed to the sun. Conversely, overnight decreases in pressure due to cooling from afternoon to early morning are normal and do not necessarily indicate a leak.
- After testing, maintain 5 to 10 psi (35 to 70 kPa) in the system during subsequent construction so that damage caused by stakes, excavation equipment, etc., can be detected and corrected before pavement is installed or product is pumped.

12 Containment system testing

Pneumatic testing

Plan tests carefully and carry them out with all due precautions. Pressurizing equipment should be suited to the size of the system and the pressure required and should be operated by qualified and experienced personnel only. Pressure sources should be capable of approaching test pressure gradually.

Use gauges with a full-scale reading of no more than twice the test pressure. Do not use a 100 psi gauge for a 10 psi test. Use reliable gauges calibrated against a dead weight tester zeroed for atmospheric pressure.

The volume of air in the interstitial space is very small, so use of a regulator is recommended to control the pressure during filling of the line.

Pneumatic testing at approximately 30 psi is recommended and is the preferred method of testing containment piping.

Provisions for testing and monitoring

The clamshell termination sleeves with test valves are equipped with a ¼ inch Schrader valve which can be used to attach pressurizing equipment. It may be necessary to remove the internal valve prior to attaching pressurization equipment. Use proper tool to do so.

Should gauge readings fail to remain stable and the testing is being done pneumatically, use a soap solution to locate leakage.

13 Simultaneous testing

Simultaneous testing of the primary and bonded containment section will not normally be done as the containment system will not be closed until the primary has passed testing. However, it may be advisable to maintain a pressure on the primary during testing of the containment in order to precisely test both systems. If this is done, the pressure in the primary should be at least 10 psi. different than the containment test pressure (higher or lower). If a leak does exist in the primary, it will be very evident due to a change in pressure in the relatively low volume containment system.

14 Health and safety information

FOR CHEMICAL EMERGENCY
SPILL, LEAK, FIRE, EXPOSURE
OR ACCIDENT

CALL CHEMTREC - DAY
OR NIGHT

1-800-424-9300

Toll-free in the continental U.S.

483-7616 in District of
Columbia

For calls originating outside the
continental U.S.

202-483-7616 -Washington D.C.
collect

ALL CALLS ARE RECORDED

Toxicity of adhesive

Hardener: Irritating to the skin, eyes and respiratory tract: toxic orally; may cause sensitization.

Resin: May be mildly irritating to skin and eyes; may cause sensitization.

Handling precautions for adhesive

Hardener: Do not get in eyes, on skin or clothing. Avoid breathing vapor. Wash thoroughly after handling. When handling in the field, wear gloves and eye protection. When handling in bulk quantities, wear rubber gloves, rubber apron and NIOSH approved respirator.

Resin: Avoid contact with eyes, skin or clothing. When handling in the field, wear gloves and eye protection. Wash thoroughly after handling.

First aid for adhesive users

In case of contact

Eyes: Immediately flush with plenty of water for at least 15 minutes. Call a physician.

Skin: Wash with water and soap if available.

Clothing: Remove contaminated clothing and wash before reuse.

Inhalation: Remove to fresh air. Give oxygen or artificial respiration if necessary.

Ingestion: If hardener is swallowed and person is conscious, give plenty of water or milk to drink. **Do not induce vomiting.** Call a physician. If resin is swallowed, give 100 grams (about ¼ lb) of activated charcoal slurry in water. **Do not induce vomiting.** Call a physician.

Important Notice



This literature and the information and recommendations it contains are based on data reasonably believed to be reliable. However, such factors as variations in environment, application or installation, changes in operating procedures, or extrapolation of data may cause different results. Ameron makes no representation or warranty, express or implied, including warranties of merchantability or fitness for purpose, as to the accuracy, adequacy or completeness of the recommendations or information contained herein. Ameron assumes no liability whatsoever in connection with this literature or the information or recommendations it contains. Product specifications are subject to change.

FIBERGLASS - COMPOSITE PIPE GROUP - HEADQUARTERS

P.O. Box 801148 • Houston, TX 77280 • Tel: (713) 690-7777 • Fax: (713) 690-2842 • <http://www.ameron.com>

Asia

Ameron (Pte) Ltd.
No. 7A, Tuas Avenue 3
Singapore 639407
Tel: 65 861 6118
Fax: 65 862 1302/861 7834

Europe

Ameron B.V.
J.F. Kennedylaan 7
4191 MZ Geldermalsen
The Netherlands
Tel: +31 345 587 587
Fax: +31 345 587 561

Americas

P.O. Box 878
Burkburnett, TX 76354
Tel: (940) 569-1471
Fax: (940) 569-2764

Composites

P.O. Box 71370
11 McBride Street
Newnan, Georgia 30263
Tel: (770) 253-2000
Fax: (770) 253-9234

Centron International

P.O. Box 490
600 FM 1195 South
Mineral Wells, Texas 76068
Tel: (940) 325-1341
Fax: (940) 325-9681