

USonic™ Series

Ultrasonic Level Transmitter



Affordable, 2-Wire Level Transmitter with the performance and features of premium, line-powered systems.

2-inch Nozzle Mounting

Compact transducer design allows mounting in any 2-inch nozzle. It also allows for a recessed nozzle mounting enabling level to be read to the very top of the vessel.

SMARTGain™

(SMARTGain™) Eliminates interfering signals from agitators and other internal vessel obstructions without the need to empty the vessel and without operator intervention. Easily ignores pipes and obstructions that are in the sonic beam path.

Two-Wire Loop Powered, HART®

30 ft. Range (9.1 meter)
Intrinsic Safety and Explosion Proof designs and Approvals (pending)

Easy set-up

Via PC software or HART Communicator
Menu driven configuration via integral display

SMARTGain™

Automatically ignores most internal obstructions
No user adjustments required

Full Tank Measurement

Transducer can be recessed in a 2-inch ID, or larger, nozzle to allow level measurements to the very top of the vessel.

Bench Configuration

Eliminates the need to move process material levels for calibration.

Level or Open Channel Flow measurements

Integrated software supports measurement in Level, Distance, Volume or Flow

User Friendly

Set the measurement range directly in inches, feet, millimeters, centimeters, or meters via the integral display with environmentally sealed keypad. The display is menu driven and can easily be configured without detailed procedures: no cryptic codes, no problems.

Level and Open Channel Flow measurements

The USonic makes measurements on level, distance, volume or open channel flow easy to configure. Preset flume and weir characterizations are included in the USonic for over 80 different flumes and weirs. Custom characterizations can be user defined for flumes/weirs that are uncommon. Each USonic contains 2 totalizers (one is user resettable).

Ideal for hazardous area installations

Units designed for either Intrinsically Safe or Explosion Proof installations in Class 1 Div. 1, Zone 0 environments.



Continuous Level Measurement

Usonic™ Series Ultrasonic Level Transmitter

Specifications

Input Power

19 to 30 VDC
19 VDC required @ 4 mA
minimum

Output signal

2-wire, 4-20mA, HART (isolated)

Maximum Loop Resistance

600 ohms at 24VDC

Output Mode

Level, Distance, Flow, Volume

Display Indications

Level, Distance, Flow rate,
Totalization, Temperature,
Signal Strength, Milliamp
User selectable, multiple
selections can be scrolled
automatically

Supported Flow elements:

Parshall
Rectangular Weirs (with and
without end contractions)
Trapezoidal (Weir and Flume)
V-Notch
Leopold-Lagco
Palmer-Bowlus
“H” Flumes

Range

1 to 30 ft. (0.3 to 9.1m)

Near Zone

12 inches (305 mm)

Minimum Span

3 inches (76 mm)

Maximum Span

30 ft. (9.1 m)

Response Time

300 millisecond

Display

2-line, 7-digit LCD
Character height: 0.25” top line,
0.36” bottom line
UV Rated - Sunshield not
required

Accuracy

+/- 0.15% or 0.2 inch (5 mm) of
sensor range, which ever is
greater

Repeatability

<0.12 inch (3 mm)

Resolution

<0.12 inch (3 mm)

Ambient Temperature Limits

-40°F to 158°F (-40°C to 70°C)

Temperature Compensation

Built-in, Automatic and readable
from display

Fail-Safe

3.7 and 22 mA error signals
– user selectable for Lost Echo
and Near Zone violations

Configuration

Local Display with Keypad (XP
version non-indicating)
PC Software (I.S. and XP
versions)
HART Communicator (I.S. and
XP versions)

Signal Damping

User programmable from 0 – 99
seconds

Auto Profiling™

Standard feature on every
system

Sensor

6.5” CPVC,
I.S. rated -40°F to +158°F at
50 psig. (-40°C to +70°C at 3.4
bar)
XP rated -12°F to +158°F at
50 psig. (-25°C to +70°C at 3.4
bar)

Sensing element connection

2-inch NPT/BSP fitting, CPVC
Flange mounting (via threaded
flanges)

Frequency

50KHz

Beam Angle

Conical, 10° (total) @ 3db down

Electrical Enclosures

PBT-RF (Valox UV Stabilized) to
NEMA 4X (IP-65)
Explosion proof, powder coated
aluminum to NEMA 4X (IP-66)

Approvals

Class I, Div. 1 & Div. 2,
Zone 0 & Zone 1 hazardous
locations. FM, CSA, CE, ATEX,

(Pending)

IEC Ex, Cepel, GOST.

Continuous Level Measurement

Usonic™ Series Ultrasonic Level Transmitter

Model Numbering

Usonic™

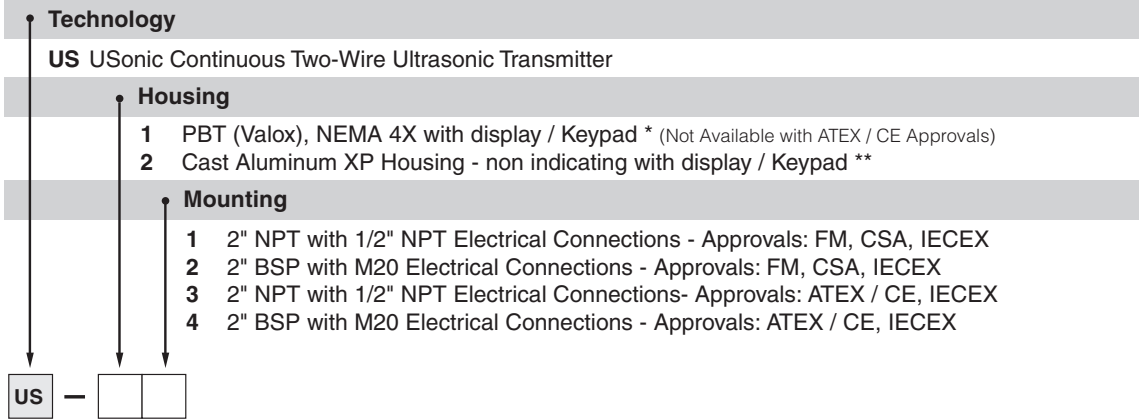

* Intrinsic Safety Approvals

** Intrinsic Safety Approvals & FM / CSA Approved Explosion Proof

* Model Number subject to change without notice

Ignore difficult internal obstructions with patented SMARTGain™

SMARTGain™ is a standard feature with every system and prevents unwanted reflections from internal obstructions and agitator blades. By automatically controlling the transmitter gain (sensitivity to returned echoes), without user intervention, it is possible to ignore obstructions that are mounted within the ultrasonic beam path. SMARTGain™ also provides measurement advantages in horizontal cylinders and spheres by reducing the effects of multiple reflection signal paths.

Ignore Obstructions in the Beam Path

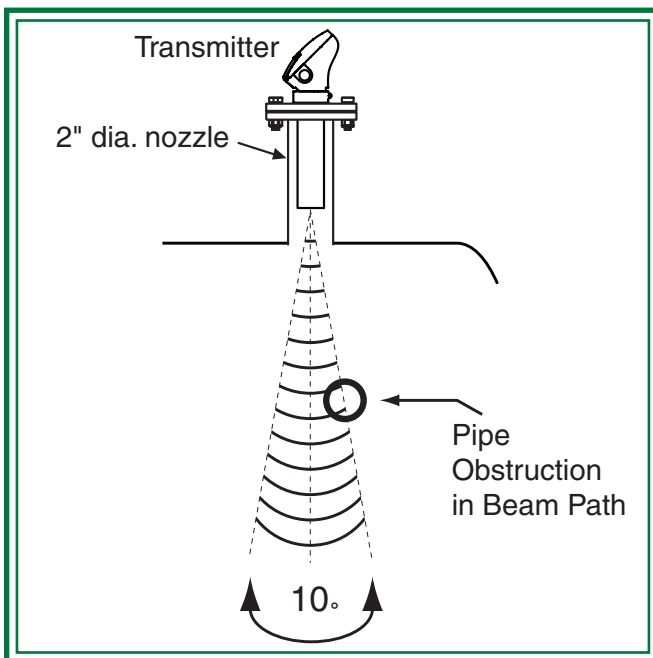

- The edge of a 2-inch (50 mm) pipe can be as close as ½ inch (12 mm) from the centerline of the transducer, and ignored.
- The edge of a 1-inch (25 mm) pipe can be 1-inch (25 mm) from the centerline of the transducer, and ignored.

Continuous Level Measurement

Usonic™ Series Ultrasonic Level Transmitter

Quick Start-up:

1. Choose Level, Distance, Volume, or Flow as an input type.
2. Choose Configuration Units (Feet, Inches, Meters, Centimeters, Millimeters).
3. Enter Tank Height.
4. Enter LRV and URV (4 & 20 mA points).

That's all that is needed to start measuring accurate Level!

Easy user-defined configuration as simple or complex as needed.

In addition to a quick and easy start-up, in-depth configuration allows the conversion of Level to Volume through internal strapping tables or open channel flow tables and totalizer settings. The Usonic has (2) 7-digit totalizers on-board for use in flow measurement inputs; one is user resettable. Systems settings allow user-defined system gain, repetition rates, time delay, error signals, display options, HART® Communication, diagnostics and more.

System Dimensional Drawings:

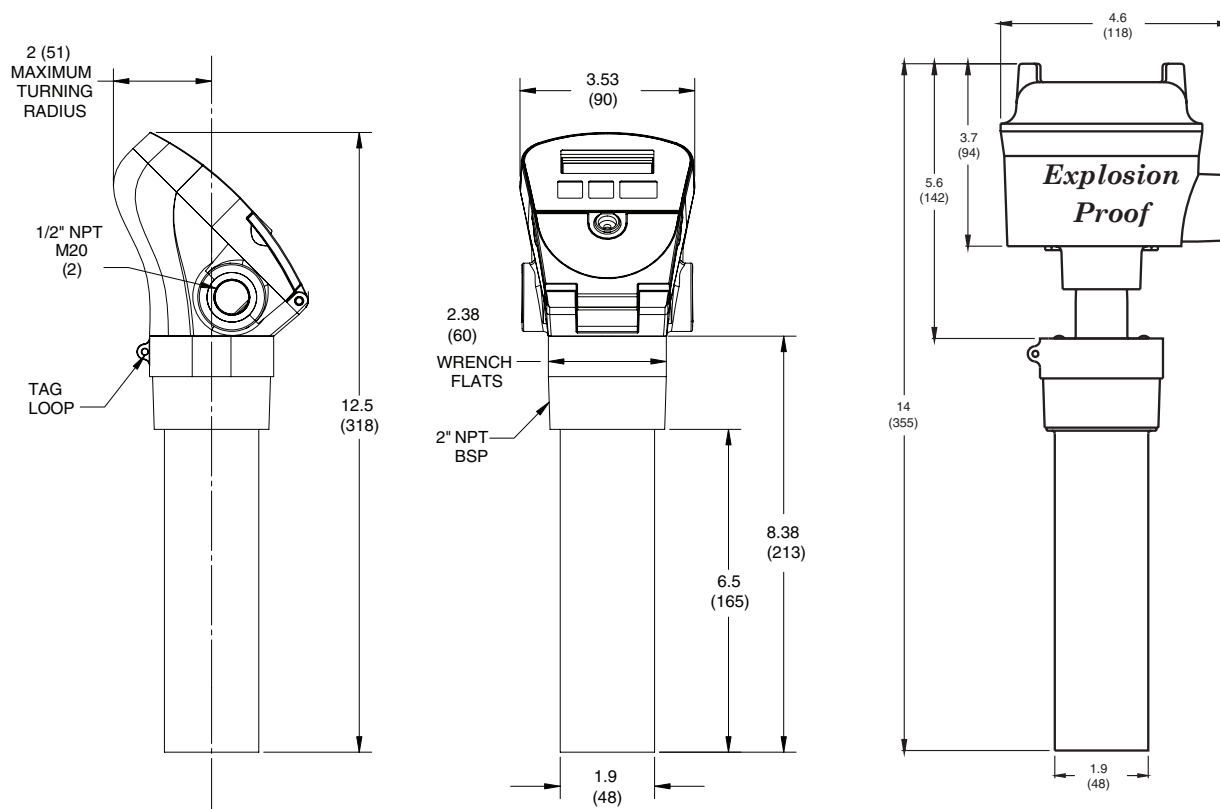

AMETEK® DREXELBROOK®

205 Keith Valley Road, Horsham, PA 19044 U.S.A.

Tel: 215-674-1234 Fax: 215 674-2731

Email: drexelbrook.info@ametek.com

Web: www.drexelbrook.com